



Content and Activities for
Term 1,2 & 3
Chemistry S4
Experimental Version

Kigali, May, 2018

Copyright

© 2018 Rwanda Education Board

All rights reserved.

This document is the property of Rwanda Education Board.

ACRONYMS AND ABBREVIATIONS

⁰C	:	Celcius degree
Atm	:	Atmosphere
Bpt	:	Boiling point
Ea	:	Activation energy
I.E	:	Ionization energy
K	:	Kelvin degree
KE	:	Kinetic energy
ME	:	Mechanic energy
Mpt	:	Melting point
Pa	:	Pascal
PE	:	Potential energy
VBT	:	Valence bond theory
VSEPR	:	Valence shell electron pair repulsion

TABLE OF CONTENT

ACRONYMS AND ABBREVIATIONS	i
TABLE OF CONTENT	ii
UNIT 1: STRUCTURE OF AN ATOM AND MASS SPECTRUM	1
1.1. Outline of the discovery of the atom constituents and their properties	2
1.1.1. Constituents of atoms and their properties	2
1.1.2. Discovery of the atom constituents.....	3
1.2. Concept of atomic number, mass number, and isotopic mass	7
1.3. Calculation of relative atomic mass of elements with isotopes	10
1.4. Description and functioning of the mass spectrometer	11
1.5. Interpretation of mass spectra.	17
1.6. Uses of the mass spectrometer and involving calculations	20
1.6.1. Uses of mass spectrometer	21
1.6.2. Calculation of RAM using mass spectrum	21
1.7. End unit assessment	23
UNIT 2: ELECTRONIC CONFIGURATION OF ATOMS AND IONS.....	27
2.1. Bohr's atomic model and concept of energy levels	28
2.1.1. Achievements of Bohr's Atomic Model	29
2.1.2. Limitations of Bohr Model.....	29
2.2. Hydrogen spectrum and spectral lines	29
2.3. Atomic spectra.....	34
2.4 Quantum Numbers.....	34
2.5 Electronic configuration of atoms and ions.....	39
2.6. Relationship between ionization energy, energy levels and factors influencing ionization energy	43
2.6.1. Concept of Ionization energy	43
2.6.2. Interpretation of a graph of successive ionization energies of an atom.....	43
2.6.3. Factors influencing the extent of ionization energy	44
2.6.4. Importance of ionization energy in the determination of the chemistry of an element	45
2.7. End unit assessment	46

UNIT 3: FORMATION OF IONIC AND METALLIC BONDS	50
3.1. Stability of atoms and why they bond together.....	51
3.2. Ionic bonding.....	52
3.2.1. Formation of ionic bond.....	52
3.2.2. Physical properties of ionic compounds	56
3.2.3. Lattice energy.....	60
3.3. Formation of metallic bonds and physical properties of metals.....	63
3.3.1. Formation of metallic bond	63
3.3.2. Physical properties of metals	64
3.3.3. Factors affecting the strength of metallic bonds.....	68
3.4. End Unit Assessment	70
UNIT 4: COVALENT BOND AND MOLECULAR STRUCTURE	75
4.1. Overlap of atomic orbitals to form covalent bonds.....	76
4.1.1 Properties of covalent molecules	79
4.2. Lewis structures.....	80
4.3 Coordinate or dative covalent bonding, properties and resonance structures	88
4.3.1. Co-ordinate or dative covalent bonding, propertie	88
4.3.2. Dative covalent bonding in complex ions	90
4.4 Valence bond theory (VBT).....	91
4.5. Valence Shell Electron Pair Repulsion Theory (VSEPR) theory	95
4.6. Types of Hybridization.....	97
4.7 Polarity of the covalent bonds.....	103
4.8. Simple and giant covalent structures.....	105
4.9. Intermolecular Forces.....	109
4.9.1. London dispersion forces	110
4.9.2. Dipole-dipole interaction.....	110
4.9.3. Hydrogen bond	111
4.10. End unit assessment	114
UNIT 5: VARIATION IN TRENDS OF THE PHYSICAL PROPERTIES	121
5.1. Historical Background of the Periodic Table.....	121
5.1.1. Law of Triads.....	122

5.1.2. Law of Octaves	122
5.2. Comparison of Mendeleev’s Table and Modern Periodic Table	124
5.3. Location of Elements in the Periodic Table Based On the Electronic Configuration.....	126
5.3.1. Major Divisions of the Periodic Table	126
5.3.2. Location of elements in modern Periodic Table using examples	127
5.3.3. Location of elements in the periodic table based on atomic orbitals	128
5.4. Classification of Elements into Blocks (s, p, d, f-block)	129
5.5. Characteristics of different blocks of the periodic table	130
5.6. Variation of Physical Properties down The Group and Across the Period	132
5.5.1. Atomic radius	133
5.5.2. Electronegativity	133
5.5.3. Ionization energy (I.E)	135
5.5.5. The melting points and boiling points	136
5.5.6. The density	138
5.5.7. Electrical and thermal conductivity	138
5.6. End unit assessment	140
UNIT 6: TRENDS IN CHEMICAL PROPERTIES OF GROUP 1 ELEMENTS AND THEIR COMPOUNDS	
.....	142
6.1. Occurrence and physical properties of group 1 elements physical state metallic character physical appearance and melting point	143
6.2. Reactivity of group 1 elements with oxygen, water and halogens.....	145
6.2.1. Reactions with Oxygen	146
6.2.2. Reaction with water	147
6.2.3. Reaction with halogens	148
6.3. Properties of group 1 oxides and hydroxides	149
6.3.1 Oxides	149
6.3.2. Hydroxides	149
6.4. The effect of heat on Group 1 carbonates and nitrates.....	150
6.4.1. Heating the nitrates	150
6.4.2. Heating the carbonates	151
6.5. Solubility of group 1 compounds	152

6.5.1. Carbonates	152
6.5.2. Hydroxides	152
6.5.3. Sulphates	152
6.6. Flame Test for Li^+ , Na^+ and K^+	153
6.7. Uses of group 1 elements and their compounds.....	154
6.8 Hydrogen.....	155
6.8.1. Properties of hydrogen atom	155
6.8.2. Production of hydrogen	156
6.8.3. Uses of hydrogen	156
6.8.4. Chemical properties of hydrogen	156
6.9. End unit assessment	157
UNIT 7: TRENDS IN CHEMICAL PROPERTIES OF GROUP 2 ELEMENTS AND THEIR COMPOUNDS	
.....	158
7.1. Occurrence and physical properties of group 2 elements	160
7.1.1. Occurrence	160
7.1.2. Physical properties	160
7.2. Reactivity of group 2 elements.....	161
7.3. Properties of group 2 compounds.....	163
7.3.1. Ionic and covalent character of oxides and halides	163
7.3.2. Trends in thermal stability of carbonates, hydroxides and nitrates	164
7.3.3. Trends in solubility of hydroxides, carbonates, hydrogencarbonates and sulphates	165
7.4. Anomalous properties of beryllium compounds	166
7.5. Identification test for Ba^{2+} ions in aqueous solutions	167
7.6. Uses of group 2 elements and their compounds.....	169
7.7. End unit assessment	171
UNIT 8: TRENDS OF CHEMICAL PROPERTIES OF GROUP 13 ELEMENTS AND THEIR COMPOUNDS	
.....	173
8.1. Physical properties of group 13 elements	173
8.3. Reaction of aluminium.....	175
8.3.1. Reaction of aluminium with oxygen	175

8.3.2. Reactions with acids	176
8.3.3. Reaction with alkalis	178
8.3.4. Reaction with halogens	178
8.4. Oxides and hydroxides of group 13 elements	180
8.5. Anomalous properties of boron.....	181
8.6. Identification of Al^{3+} ion in solution	182
8.7. Uses of some group 13 elements.....	183
8.8. End unit assessment	184
UNIT 9: TRENDS IN CHEMICAL PROPERTIES OF GROUP 14 ELEMENTS AND THEIR COMPOUNDS	185
9.1. Physical properties of group 14 elements.	186
9.2. Chemical properties of Group 14 elements.....	190
9.3 Distinguish between the chemical reactions of the oxides and chlorides of Group 14 elements.....	193
9.4. Explain the trends in thermal stability of the oxide, halides and hydroxides of Group 14 elements.....	196
9.4.1. Stability of oxides of group 14 elements	196
9.4.2. Thermal stability of halides of group 14 elements	197
9.4.3. Thermal stability of hydroxides of group 14 elements	197
9.4.4. Chemical tests of Sn^{2+}, Pb^{2+}, HCO_3^- :	197
9.5 Explain the variation in stability of oxidation state of +2 and +4 down the Group 14 elements.....	200
9.6 Uses of Group 14 elements	201
9.7 Define diagonal relationship	203
9.7.1. Define the diagonal relationship	204
9.7.2. Diagonal Relationship of Li with Mg:	204
9.7.3. Diagonal Relationship of Be with Al	205
9.7.4. Diagonal relationship between Boron and Silicon	205
9.8. End unit assessment	206
UNIT 10: TRENDS IN CHEMICAL PROPERTIES OF GROUP 15 ELEMENTS AND THEIR COMPOUNDS	207
10.1. Physical properties of group 15 elements and the relative inertness of nitrogen	208

10.1.1. Physical properties of group 15 elements	209
10.1.2. The relative inertness of nitrogen	210
10.2. Reactions of group 15 elements	211
10.3. Ammonia and nitric acid	213
10.3.1. Laboratory preparation of ammonia and nitric acid	214
10.3.2. Industrial production of ammonia and nitric acid	215
10.4. Phosphorus and chemical properties of its compounds	222
10.4.1. Allotropes of phosphorus	223
10.4.2. Chemical properties of phosphorous compounds	224
10.4.3. Phosphoric acid	225
10.4.4. Identification of PO_4^{3-} and NO_3^- ions	226
10.4.5. Uses of group 15 elements and compounds	227
10.5 End unit assessment	229
UNIT 11: TRENDS OF CHEMICAL PROPERTIES OF GROUP 16 ELEMENTS AND THEIR COMPOUNDS	
.....	231
11.1. Physical properties of group 16 elements	232
11. 1.1. Physical state and metallic character of group 16 elements	232
11.1.2. Allotropes of oxygen and sulphur	233
11.1. Comparison of acidity and volatility of group 16 hydrides	235
11.2. Preparation and properties of sulphuric acid	236
11.3.1. Industrial preparation of sulphuric acid and its environmental impact	237
11.3.2. Oxidising and dehydrating properties of sulphuric acid	239
11.3. Properties of oxoanion of sulphur	239
11.4.1. Reducing action of $\text{S}_2\text{O}_3^{2-}$	241
11.4.2. Reaction OF SO_3^{2-} with acids	241
11.4.3. Action of heat on sulphates (SO_4^{2-})	242
11.4. Identification of sulphite and sulphate ions	243
11.5.1. Identification of sulphate ion (SO_4^{2-})	244
11.5.2. Identification of sulphite ion (SO_3^{2-})	244
11.5. Uses of group 16 elements and compounds	245
11.6.1. Uses of oxygen	246

11.6.2. Uses of sulphur	246
11.6.3. Uses of sulphuric acid	246
11.6.4. Uses of hydrogen sulphide (H₂S)	246
11.7. End unit assessment	247
UNIT 12: TRENDS OF CHEMICAL PROPERTIES OF GROUP 17 ELEMENTS AND THEIR COMPOUNDS	248
12.1 Natural occurrence of halogens.....	249
12.2. Extraction methods of halogens	250
12.2.1. Chlorine	252
12.2.2. Fluorine	253
12.2.3. Bromine	253
12.2.4. Iodine	253
12.3. Trends of physical and chemical properties of group 17 elements down the group.....	253
12.3.1. Physical properties of group 17 elements down the group	254
12.3.2. Trend in chemical properties of group 17 elements down the group	255
12.3.3. Preparation of hydrohalic acids	258
2.4. Trends in strength of acidity, volatility and reducing power of hydrogen halides.....	260
12.4.1. Acid strength	260
12.4.2. Volatility	260
12.4.3. Reducing power	261
12.5. Chemical properties of chlorates, iodates, perchlorates and periodates.....	262
12.6. Uses of halogens and their compounds	266
12.6.1. Uses of Halogens	266
12.6.2. Hazards caused by group 17 elements	266
12.7. End of unit assessment	267
UNIT 13: PROPERTIES AND USES OF GROUP 18 ELEMENTS AND THEIR COMPOUNDS.....	269
13.1. Occurrence and physical properties of noble gases	270
13.1.1. Occurrence	270
13.1.2. Physical properties	270
13.2. Reactivity and inertness of noble gases.....	271
13.3. Discovery of first noble gas compound and uses of noble gases	272

13.4. Uses of noble gases	272
13.5. End unit assessment	274
UNIT 14: TRENDS IN CHEMICAL PROPERTIES OF PERIOD 3 ELEMENTS AND THEIR COMPOUNDS	275
14.1. Physical Properties of the Period 3 elements	275
14.2. Chemical properties of period 3 elements.....	282
14.3. Compound of period 3 elements	284
14.4 Acid-base Behavior of the Oxides	286
14.5. End unit assessment	295
UNIT15: FACTORS THAT AFFECT CHEMICAL EQUILIBRIUM	297
15.1. Difference between complete and incomplete reactions (reversible versus irreversible reactions)	299
15.2. Concept of equilibrium (dynamic equilibrium) and their Characteristics.....	301
15.2.1. Concept of equilibrium reactions	301
15.1.2. Characteristics of a system in a dynamic equilibrium	303
15.3. Factors that affect the reactions in equilibrium and Le Châtelier’s principle	304
15.3.1. Effect of Temperature on equilibrium.....	305
15.3.2. The effect of change in concentration on equilibrium.....	306
15.3.3. Effect of Changing Pressure	309
15.3.4. The effect of a catalyst on equilibrium	311
15.4. End unit assessment	312
UNIT 16: ACIDS AND BASES.....	316
16.1 Acid-Base Theories	317
16.1.1. Arrhenius’ Theory of Acid-Base	318
16.1.2. Brønsted-Lowry’s Acid-Base Theory: Acid-base conjugate pairs.....	321
16.1.3. Lewis’s Acid-Base Theory.....	323
16.2. End unit Assessment	325
UNIT17: REDUCTION AND OXIDATION REACTIONS.....	326
17.1. Definition of electrochemistry and its relationship with redox reactions.	327
17.2. Definitions of reduction and oxidation reactions.	328
17.2.1. Introduction	328

17.2.2. Oxidation reactions as a loss of electrons and reduction as a gain of electrons.	329
17.3. Explanation of oxidizing and reducing agents	330
17.4. Rules used to determine oxidation numbers of elements in chemical compounds and species	331
17.5. Balancing of Redox equations	333
17.5.1. Rules for balancing redox reactions	334
17.5.2. Concept of disproportionation reactions	337
17.6. Reactivity series of metals.....	337
17.7. End unit assessment	341
UNIT 18: ENERGY CHANGES AND ENERGY PROFILE DIAGRAMS	344
18.1. Concept of a system	346
18.2. The internal Energy of a system and first Law of Thermodynamics	350
18.2.1. Internal energy	350
18.2.2. Heat energy and temperature	350
18.3. Standard Enthalpy changes	355
18.4 Energy profile diagrams for Exothermic and Endothermic reactions.....	359
18.7. End unit Assessment	365
REFERENCES	366

UNIT 1: STRUCTURE OF AN ATOM AND MASS SPECTRUM

Key unit competency

Interpret simple mass spectra and use them to calculate the relative atomic mass (R.A.M) of different elements.

Learning objectives

By the end of this unit, I will be able to:

- Outline the discovery of the sub-atomic particles.
- Compare the properties of sub-atomic particles.
- Explain what is an isotope of an element
- Assess the relationship between the number of protons and the number of electrons
- Calculate the mass number knowing the number of protons and the number of neutrons
- Understand the meaning of relative atomic mass and relative abundances
- Calculate the relative atomic mass of an element, given isotopic masses and abundances.
- Draw and label the mass spectrometer.
- Explain the fundamental processes occurring in the functioning of a mass spectrometer.
- Interpret different mass spectra.
- State the uses of the mass spectrometer.
- Calculate the relative atomic mass of an element, from a mass spectrum.

Introductory activity 1

The presentations A, B, and C below show three atomic nuclei of different elements. Study the presentations carefully and answer the questions below.



(A)

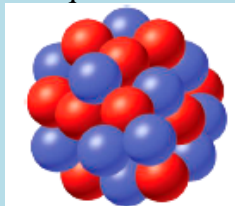

(B)

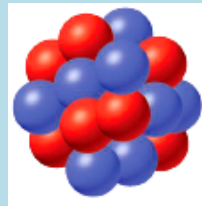

(C)

1. How many blue and red spheres are in each of the diagrams above?
2. What do the three diagrams A, B, and C have in common?
3. Based on your knowledge concerning atomic structure, what do you think that
 - a) the blue spheres represent?
 - b) the red spheres represent?Provide explanations.
4. Using the information obtained in question (3) write the atomic symbol for each of the diagrams.
5. Are there some other particle(s) missing from the above diagrams? If yes name the particle(s).
6. What could you obtain if the atom is broken down?

Each country has its own culture (language, traditions and norms, attitudes and values, etc.). Our culture defines our identity which is unique to each Rwandan citizen and differentiates us from foreigners; if one of elements our culture is rejected or disappears, we become a different Rwandan people. When we introduce foreign cultures to replace ours, we can lose our identity. However, some of our cultural elements such as language can be shared with others to build the social relationship.

Similarly, in the atom, the number of protons within the nucleus defines the atomic number, which is unique to each chemical element; the atomic number or the number of protons of an atom defines its identity. If a proton is added or removed from an element, it becomes a different element. Electrons around the nucleus can be lost, gained, or shared to create bonds with other atoms in chemical reactions to produce useful substances.

1.1. Outline of the discovery of the atom constituents and their properties

Activity 1.1

1. Regardless of some exceptions, all atoms are composed of the same components. True or False? If this statement is true why do different atoms have different chemical properties?
2. The contributions of Joseph John Thomson and Ernest Rutherford led the way to today's understanding of the structure of the atom. What were their contributions?
3. Explain the modern view of the structure of the atom?
4. How do the particles in an atom relate to each other?

1.1.1. Constituents of atoms and their properties

Atoms are the basic units of elements and compounds. In ordinary chemical reactions, atoms retain their identity. An *atom* is the smallest identifiable unit of an *element*. There are about 91 different naturally occurring elements. In addition, scientists have succeeded in making over 20 synthetic elements (elements not found in nature).

An element is defined as a substance that cannot be broken down by ordinary chemical methods. Some examples of elements include hydrogen (H), helium (He), potassium (K), carbon (C), and mercury (Hg). A substance made of only one type of atom is called also element or elemental substance, for example: hydrogen (H₂), chlorine (Cl₂), sodium (Na). Elements are the basic building blocks of more complex matter.

A compound is a matter formed by the combination of two or more different elements in fixed ratios. Consider, Hydrogen peroxide (H₂O₂) is a compound composed of two elements, hydrogen and oxygen, in a fixed ratio (2:2).

During the early twentieth century, scientists discovered that atoms can be divided into more basic particles. Their findings made it clear that atoms contain a central portion called the **nucleus**. The nucleus contains protons and neutrons. **Protons** are positively charged, and

neutrons are neutral. Whirling about the nucleus are particles called **electrons** which are negatively charged. The relative masses and charges of the three fundamental particles are shown in Table 1.1

Table 1.1: Subatomic particles and some of their properties

Particle	Absolute charge(Coulomb)	Relative charge	Mass (kg)	Relative masse
Neutron(n)	0	0	1.675×10^{-27}	1.0087 amu*
Proton(p or P ⁺)	$+1.6 \times 10^{-19}$	+1	1.673×10^{-27}	1.0073 amu
Electron(e ⁻)	-1.6×10^{-19}	-1	9.11×10^{-31}	0.00054858 amu

(*amu: atomic mass unity, 1 amu= 1.67×10^{-27} kg)

The mass of an electron is very small compared with the mass of either a proton or a neutron. The charge on a proton is equal in magnitude, but opposite in sign, to the charge on an electron.

1.1.2. Discovery of the atom constituents.

The oldest idea in science was advanced by the Greek philosopher Democritus in 400BC. He suggested that matter can be divided into small particles up to an ultimate particle that cannot any more be divided, and called that particle atom. Atoms came from the Greek word *atomos* meaning indivisible.

The work of Dalton and other scientists such as Avogadro, etc., contributed more so that chemistry was beginning to be understood. They discovered a clear good idea of atoms. Certainly, scientists started to think about the nature of the atom. What are the constituents of an atom, and what are the features that make atoms of the various elements to differ?

In 1808 Dalton published *A New System of Chemical Philosophy*, in which he presented his theory of atoms:

Dalton's Atomic Theory

1. Each element is made up of tiny particles called atoms.
2. The atoms of a given element are identical; the atoms of different elements are different in some fundamental way or ways.
3. Chemical compounds are formed when atoms of different elements combine with each other. A given compound always has the same relative numbers and types of atoms.
4. Chemical reactions involve reorganization of the atoms—changes in the way they are bound together. The atoms themselves are not changed in a chemical reaction.

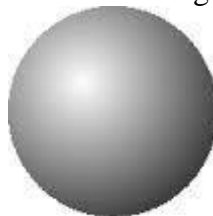

Figure 1.1: John Dalton's Atomic Model

a) Discovery of Electrons

In 1897 J. J. Thomson (1856–1940) and other scientists conducted several experiments, and found that atoms are divisible. They conducted experiments with gas discharge tubes. A gas discharge tube is shown in Figure 1.2.

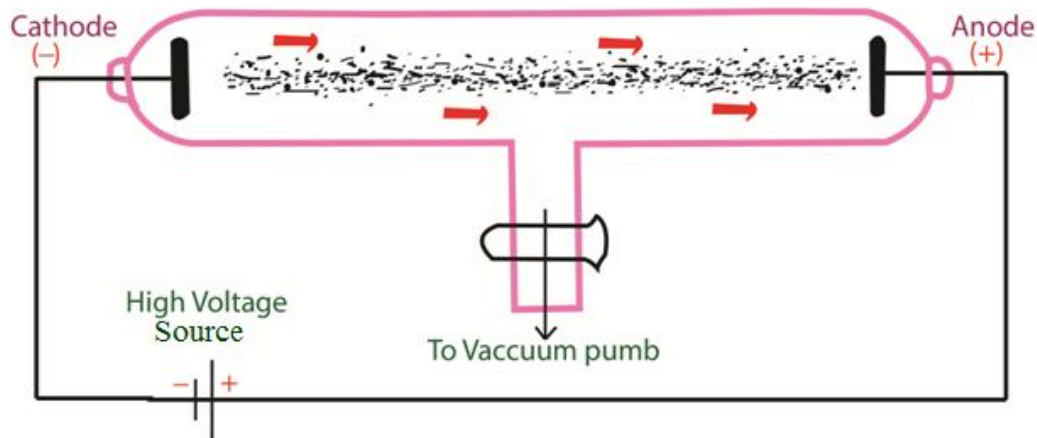

Figure 1.2: Gas discharge tube showing cathode rays originating from the cathode

The gas discharge tube is an evacuated glass tube and has two electrodes, a cathode (negative electrode) and an anode (positive electrode). The electrodes are connected to a high voltage source. Inside the tube, an electric discharge occurs between the electrodes.

The discharge or 'rays' originate from the cathode and move toward the anode, and hence are called **cathode rays**. Using luminescent techniques, the cathode rays are made visible and it was found that these rays are deflected away from negatively charged plates. The scientist J. J. Thomson concluded that the cathode ray consists of negatively charged particles, and he called them *electrons*.

Thomson postulated that an atom consisted of a diffuse cloud of positive charge with the negative electrons embedded randomly in it. This model, shown in Figure 1.3, is often called the *plum pudding model* because the electrons are like raisins dispersed in a pudding (the positive charge cloud), as in plum pudding.

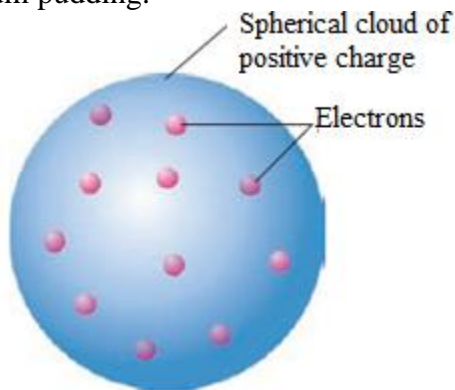

Figure 1.3. The plum pudding model of the atom.

In 1909 Robert Millikan (1868–1953) conducted the famous charged oil drop experiment and came to several conclusions: He found the magnitude of the charge of an electron equal to $-1.602 \times 10^{-19} \text{ C}$. From the charge-to-mass ratio (e/m) determined by Thomson, the mass of an electron was also calculated.

$$\frac{\text{Charge}}{\text{Mass}} = -1.76 \times 10^8 \text{ Colomb/gram}$$

$$\text{Mass} = \frac{-1.6 \times 10^{-19}}{-1.76 \times 10^8} = 9.11 \times 10^{-29} \text{ g} = 9.11 \times 10^{-31} \text{ kg}$$

a) Discovery of Protons

In 1886 Eugene Goldstein (1850–1930) observed that a cathode-ray tube also generates a stream of positively charged particles that move towards the cathode. These were called **canal rays** because they were observed occasionally to pass through a channel, or “canal,” drilled in the negative electrode (Figure 1.4). These *positive rays*, or *positive ions*, are created when the gaseous atoms in the tube lose electrons. Positive ions are formed by the process

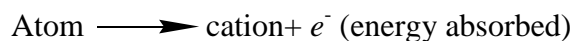

Different elements give positive ions with different e/m ratios. The regularity of the e/m values for different ions led to the idea that there is a subatomic particle with one unit of positive charge, called the **proton**. The proton is a fundamental particle with a charge equal in magnitude but opposite in sign to the charge on the electron. Its mass is almost 1836 times that of the electron.

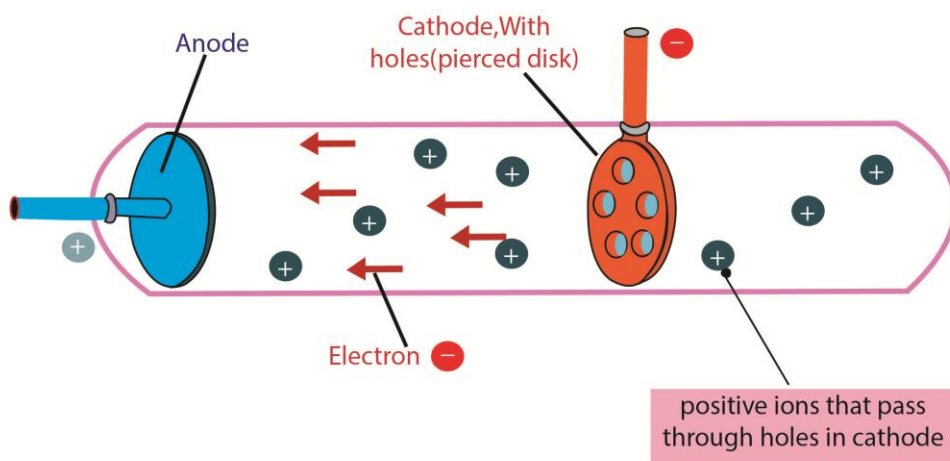

Figure 1.4: A cathode-ray tube with a different design and with a perforated cathode

The proton was observed by Ernest Rutherford and James Chadwick in 1919 as a particle that is emitted by bombardment of certain atoms with α -particles.

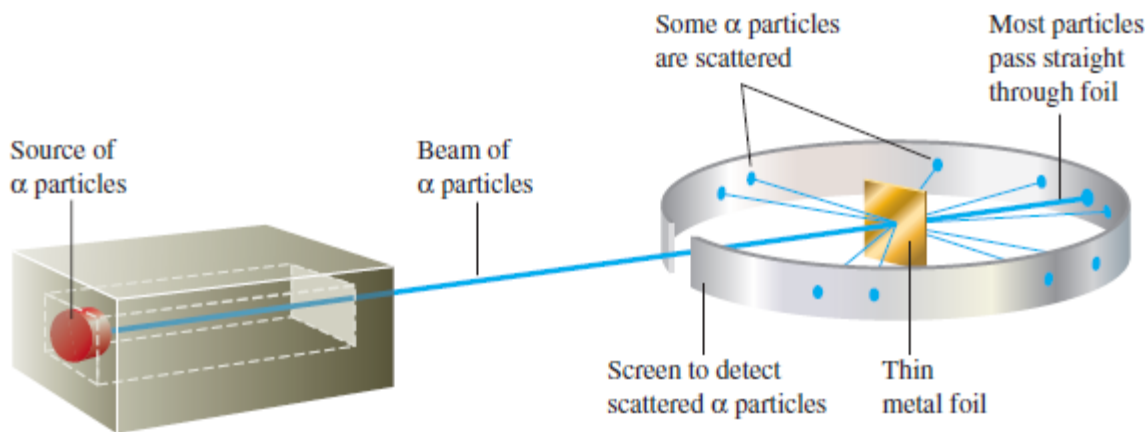

Figure 1.5: Rutherford's experiment on α -particle bombardment of metal foil

Rutherford reasoned that if Thomson's model were accurate, the massive α -particles should crash through the thin foil like cannonballs through gauze, as shown in Figure 1.6(a). He expected α -particles to travel through the foil with, at the most, very minor deflections in their paths. The results of the experiment were very different from those Rutherford anticipated. Although most of the α -particles passed straight through, many of the particles were deflected at large angles, as shown in Figure 1.6(b), and some were reflected, never hitting the detector. This outcome was a great surprise to Rutherford. Rutherford knew from these results that the plum pudding model for the atom could not be correct. The large deflections of the α -particles could be caused only by a center of concentrated positive charge that contains most of the atom's mass, as illustrated in Figure 1.6(b). Most of the α -particles pass directly through the foil because the atom is mostly open space. The deflected α -particles are those that had a "close encounter" with the massive positive center of the atom, and the few reflected α -particles are those that made a "direct hit" on the much more massive positive center.

In Rutherford's mind these results could be explained only in terms of a **nuclear atom**—an atom with a dense center of positive charge (the **nucleus**) with electrons moving around the nucleus at a distance that is large relative to the nuclear radius.

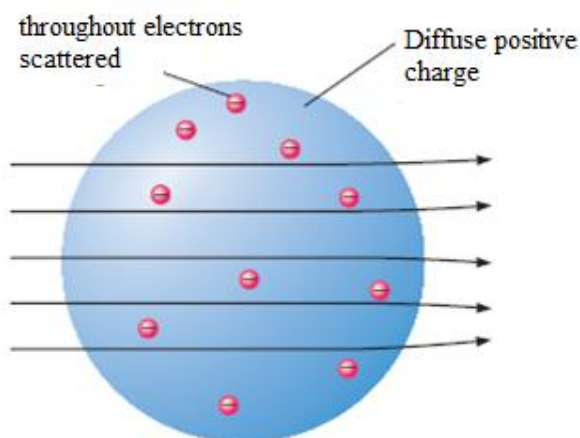

Figure 1.6 (a) The expected results of the metal foil experiment if Thomson's model were correct

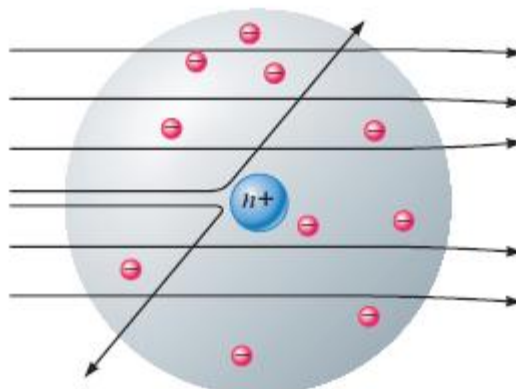

Figure 1.6:(b) Actual results

b) Discovery of Neutrons

In 1932 physicist James Chadwick discovered other subatomic particle named *neutron*, a neutral-charged particle with a mass slightly greater than that of proton.

Figure 1.7 shows the location of the elementary particles (protons, neutrons, and electrons) in an atom. There are other subatomic particles, but the electron, the proton, and the neutron are the three fundamental components of the atom that are important in chemistry.

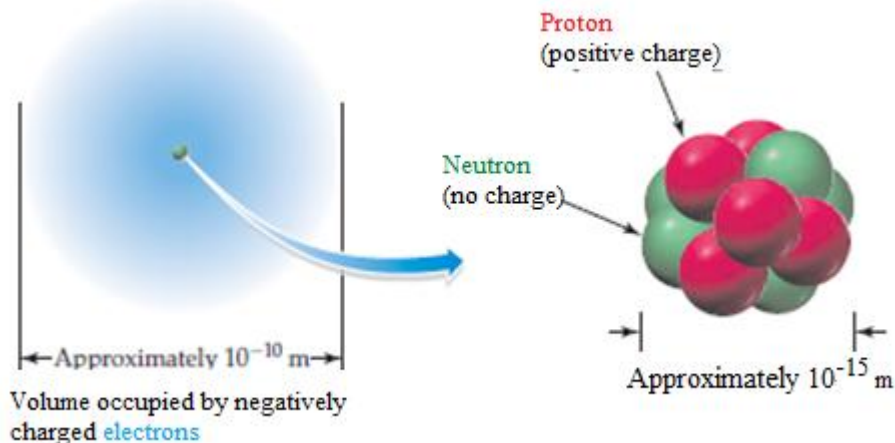

Figure 1.7: The protons and neutrons in an atom are contained in the tiny volume of the nucleus. Electrons are distributed within the sphere surrounding the nucleus.

Atoms consist of very small, very dense nuclei surrounded by clouds of *electrons* at relatively great distances from the nuclei. All nuclei contain *protons*; nuclei of all atoms except the common form of hydrogen also contain *neutrons*.

Checking up 1.1

1. In an experiment, it was found that the total charge on an oil drop was 5.93×10^{-18} C. How many negative charges does the drop contain?
2. All atoms of the elements contain three fundamental particles. True or false? Give an example to support your answer.
3. Compare the atom constituents
 - a) in terms of their relative masses
 - b) in terms of their relative charges
4. Using the periodic table as a guide, specify the number of protons and electrons in a neutral atom of each of these elements.
 - a. carbon (C)
 - b. calcium (Ca)
 - c. chlorine (Cl)
 - d. chromium (Cr)

1.2. Concept of atomic number, mass number, and isotopic mass

Activity 1.2

The diagram below shows a representation of the sodium isotopes (${}^A_Z\text{Na}$). Observe it and answer to the questions below

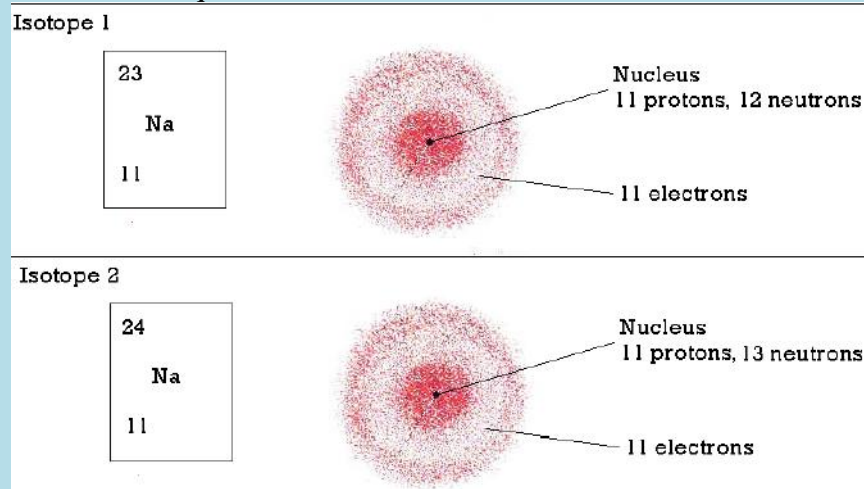

1. Compare the two sodium isotopes in the model above.
2. From your observation, how do you define the isotopes of an element?
3. How is the mass number, A , determined?
4. What information is provided by the atomic number, Z ?
5. What is the relationship between the number of protons and the number of electrons in an atom?
6. Where are the electrons, protons, and neutrons located in an atom?
7. Why is the mass of an atom concentrated in the center?
8. Sodium-24 and sodium-23 react similarly with other substances. Explain the statement
9. Say which one(s) of the following statements is(are) correct and which one(s) is(are) wrong: (i) isotopes differ in their number of electrons, (ii) isotopes differ in their mass numbers, (iii) isotopes differ in their number of protons, (iv) isotopes differ by their number of neutrons, (v) all the statements are wrong.

The **atomic number** denotes the number of protons in an atom's nucleus. The **mass number** denotes the total number of protons and neutrons. Protons and neutrons are often called **nucleons**. By convention, the atomic number is usually written to the left of the elemental notation, and the mass number to the left above the elemental notation as represented by the example below, where X represents any elemental symbol.

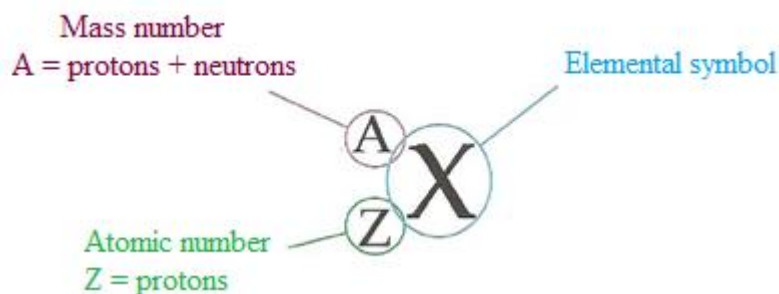

Some atoms the same of element have the same atomic number, but different mass numbers. This means a different number of neutrons. Such atoms are called **isotopes**

Isotopes are atoms of the same element with different masses; they are atoms containing the same number of protons but different numbers of neutrons.

In a given atom, the number of protons, also called “**atomic number**” are equal to the number of electrons because the atom is electrically neutral. The sum of the number of protons and neutrons (**neutron number**) in an atom gives the **mass number** of that atom.

$$\begin{aligned} \text{Mass number} &= \text{number of protons} + \text{number of neutrons} \\ &= \text{atomic number} + \text{neutron number} \end{aligned}$$

Checking up 1.2

1. Are the members of each pair isotopes? How do you qualify each pair of element? Explain.

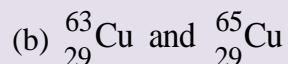
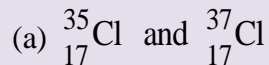

2. Write, using the periodic table, the correct symbols to identify an atom that contains
- (a) 4 protons, 4 electrons, and 5 neutrons;
 - (b) 23 protons, 23 electrons, and 28 neutrons;
 - (c) 54 protons, 54 electrons, and 70 neutrons; and
 - (d) 31 protons, 31 electrons, and 38 neutrons.
3. Use the list of the words given below to fill in the blank spaces. Each word will be used once.

Atomic number, Mass number, protons, Electrons, Isotopes, neutron

- (a) The atomic number tells you how many _____ and _____ are in an atom.
_____ is the number written as subscript on the left of the atomic symbol.
- (b) The total number of protons and neutrons in an atom is called the _____.
- (c) Atoms with the same number of protons but different number of neutrons are called _____.
- (d) The subatomic particle that has no charge is called a _____.

1.3. Calculation of relative atomic mass of elements with isotopes

Activity 1.3

1. Argon has three naturally occurring isotopes: argon-36, argon-38, and argon-40. Based on argon's reported relative atomic mass from the periodic table, which isotope do you think is the most abundant in nature? Explain.
2. Calculate the average atomic mass of an element with two naturally occurring isotopes: ^{85}X (72.15%, 84.9118 amu) and ^{87}X (27.85%, 86.9092 amu). Identify this element?
3. Boron has two naturally occurring isotopes. Find the percent abundances of ^{10}B and ^{11}B given the isotopic mass of $^{10}\text{B} = 10.0129$ amu and the isotopic mass of $^{11}\text{B} = 11.0093$ amu.

Relative atomic mass, symbolized as R.A.M or A_r , is defined as the mass of one atom of an element relative to 1/12 of the mass of an atom of carbon-12, which has a mass of 12.00 atomic mass units. The relative atomic mass, also known as the atomic weight or average atomic weight, is the average of the atomic masses of all of the element's isotopes.

Relative isotopic mass is like relative atomic mass in that it deals with atoms. The difference is that we are dealing with *different forms* of the same element. Isotopes have the same number of protons, but different numbers of neutrons. Hence, isotopes of an element have different masses. Thus, the different isotopic masses of the same elements and the percentage abundance of each isotope of an element must be known in order to accurately calculate the relative atomic mass of an element.

Notice: Remember that mass number is not the same as the relative atomic mass or isotopic mass! The mass number is the number of protons + neutrons; while relative atomic mass (or isotopic mass) is the mass if you were to somehow weigh it on a balance.

Let $A_1, A_2, A_3, \dots, A_n$ be an abundance of n isotopes of the same chemical element with atomic mass $M_1, M_2, M_3, \dots, M_n$ respectively, the relative atomic mass (R.A.M) is given by the following equation:

$$\text{RAM} = \frac{A_1 M_1 + A_2 M_2 + A_3 M_3 + \dots + A_n M_n}{A_1 + A_2 + A_3 + \dots + A_n}$$

Example 1: Oxygen contains three isotopes ^{16}O , ^{17}O , and ^{18}O . Their respective relative abundances are 99.76%, 0.04%, and 0.20%. Calculate the relative atomic mass of oxygen.

Solution:

Relative isotopic mass of ^{16}O is 16 and its relative abundance is 99.76%;

Relative isotopic mass of ^{17}O is 17, abundance 0.04%;

Relative isotopic mass of ^{18}O is 18, abundance 0.20%.

$$\text{Relative atomic mass of oxygen} = \frac{(99.76 \times 16) + (0.04 \times 17) + (0.20 \times 18)}{99.76 + 0.04 + 0.20} = 16.0044$$

By applying the same formula, the relative abundance of the isotopes may be calculated knowing the relative atomic mass of the element and the atomic masses of the respective isotopes.

Example 2: Chlorine contains two isotopes ^{35}Cl and ^{37}Cl , what is the relative abundance of each isotope in a sample of chlorine if its relative atomic mass is 35.5?

Solution:

$$35.5 = \left(\frac{A \times 35}{100} \right) + \left(\frac{100 - A}{100} \right) \times 37$$

Note that if the abundance of the isotope of atomic mass 35 is A%, the abundance of the isotope of mass 37 will be (100 – A) %.

$$0.35A + (100 - A) \times 0.37 = 35.5$$

$$0.35A - 0.37A = 35.5 - 37$$

$$-0.02A = -1.5$$

$$A = 1.5/0.02 = 75$$

Therefore, the abundance of the isotope of relative atomic mass 35.5 is 75% while that for the isotope ^{37}Cl is 100 – 75 = 25%.

Checking up 1.3

1. Three isotopes of magnesium occur in nature. Their abundances and masses, determined by mass spectrometry, are listed in the following table. Use this information to calculate the relative atomic mass of magnesium.

Isotope	% abundance	Mass (amu)
^{24}Mg	78.99	23.98504
^{25}Mg	10.00	24.98584
^{26}Mg	11.01	25.98259

2. The atomic weight of gallium is 69.72 amu. The masses of the naturally occurring isotopes are 68.9257 amu for ^{69}Ga and 70.9249 amu for ^{71}Ga . Calculate the percent abundance of each isotope.

1.4. Description and functioning of the mass spectrometer

Activity 1.4: By using the information in this book and other sources, attempt to answer the following questions

1. Define the mass spectrometer and state the main stages of its functioning.
2. Given below is the block diagram of the mass spectrometer. Identify the unmarked

component.

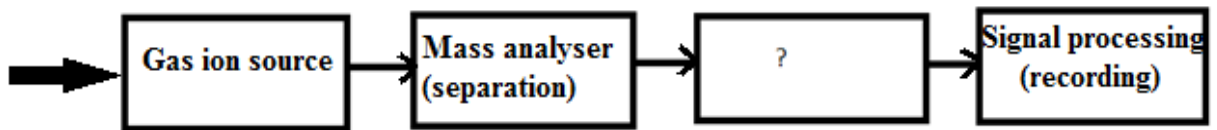

- a) Inlet system
- b) Ionisation chamber
- c) Vacuum system
- d) Ion transducer

3. Which of the following can be introduced into the ionization chamber directly?

- a) Solid samples with low vapour pressure
- b) Solid samples with high vapour pressure
- c) Liquid samples with low density
- d) Liquid samples with high density

4. Inlet system is also known as which of the following?

- a) Initial system
- b) Sample reservoir
- c) Sample handling system
- d) Element injection system

The mass spectrometer is an instrument that separates positive gaseous atoms and molecules according to their mass-charge ratio and that records the resulting mass spectrum.

In the mass spectrometer, atoms and molecules are converted into ions. The ions are separated as a result of the deflection which occurs in a magnetic and electric field.

The basic components of a mass spectrometer are: vaporisation chamber (to produce gaseous atoms or molecules), ionization chamber (to produce positive ions), accelerating chamber (to accelerate the positive ions to a high and constant velocity), magnetic field (to separate positive ions of different m/z ratio), detector (to detect the number and m/z ratio of the positive ions) and the recorder (to plot the mass spectrum of the sample).

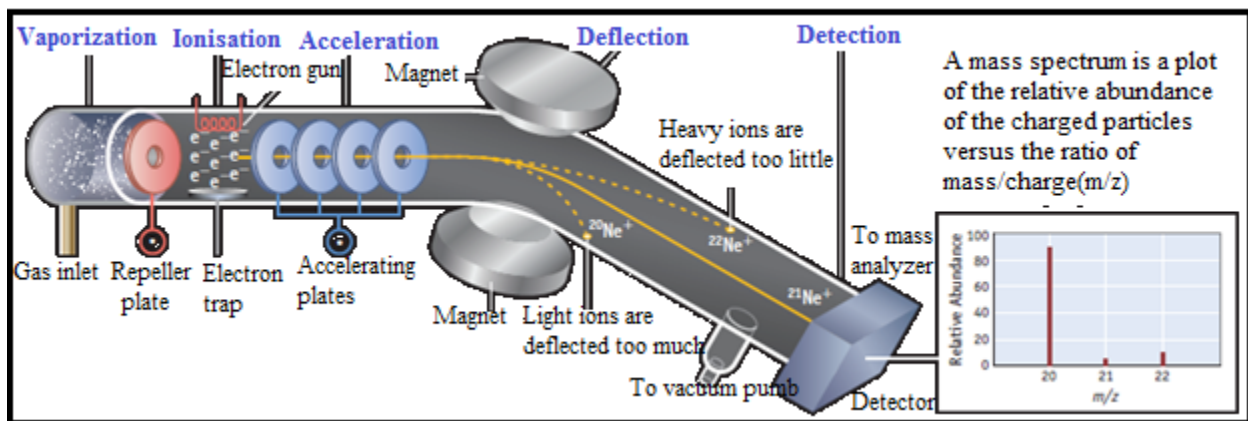

Figure 1.8: Diagram of Mass spectrometer and its functioning (source:Kotz, et al., (2012).*Chemistry & Chemical Reactivity*, Eighth Edition)

A mass spectrometer works in five main stages, namely vaporization, ionization, acceleration, deflection, and detection to produce the mass spectrum.

Stage 1: Vaporization

At the beginning the test sample is heated until it becomes vapour and is introduced as a vapour into the ionization chamber. When a sample is a solid with low vapour pressure, it can directly be introduced into the ionization chamber.

Stage 2: Ionisation

The vaporized sample passes into the ionization chamber (with a positive voltage of about 10,000 volts). The electrically heated metal coil gives off electrons which are attracted to the electron trap which is a positively charged plate.

The particles in the sample (atoms or molecules) are therefore bombarded with a stream of electrons (electron gun), and some of the collisions are energetic enough to knock one or more electrons out of the sample particles to make positive ions. Mass spectrometers always work with positive ions.

Most of the positive ions formed will carry a charge of +1 because it is much more difficult to remove further electrons from an already positive ion.

Most of the sample molecules are not ionized at all but are continuously drawn off by vacuum pumps which are connected to the ionization chamber (figure 1.9). Some of the molecules are converted to negative ions through the absorption of electrons.

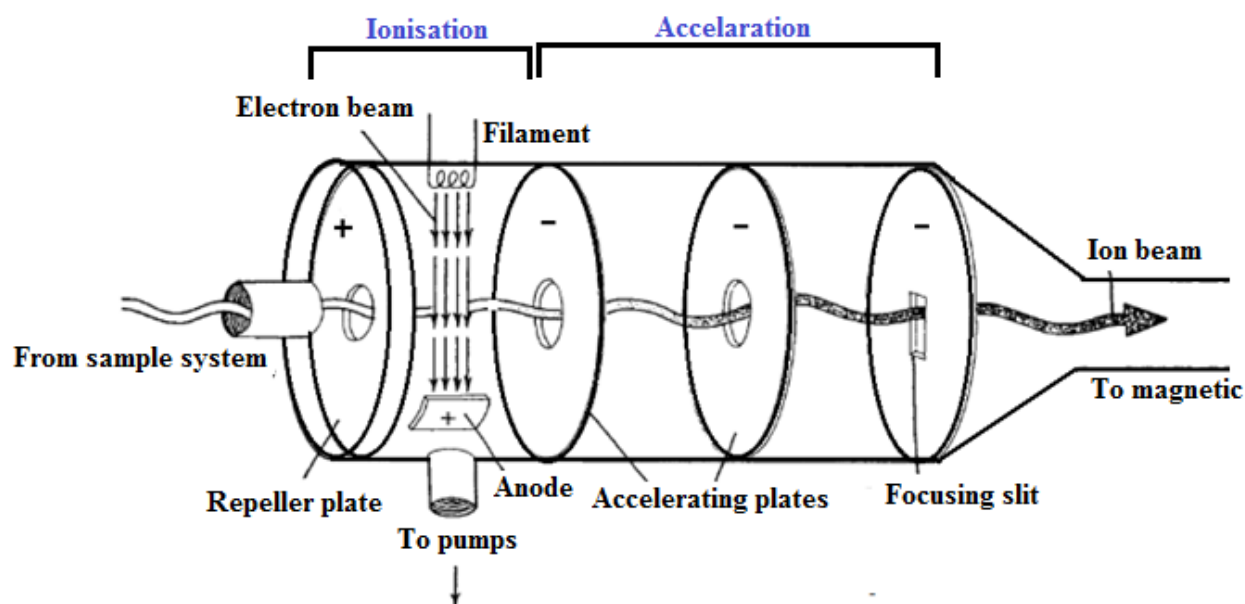

Figure 1.9: A typical ionisation chamber and the nearby accelerating plates.

The repeller plate absorbs these negative ions. A small proportion of the positive ions which are formed may have a charge greater than one (a loss of more than one electron). These are accelerated in the same way as the singly charged positive ions.

Stage 3: Acceleration

The positive ions are accelerated by an electric field so that they move rapidly through the machine at high and constant velocity.

Stage 4: Deflection

The ions are then *deflected by a magnetic field* according to their masses and charges ratio. Different ions are deflected by the magnetic field at different extents. The extent to which the beam of ions is deflected depends on four factors:

1. *The magnitude of the accelerating voltage (electric field strength).* Higher voltages result in beams of more rapidly moving particles that are deflected less than the beams of the more slowly moving particles produced by lower voltages.
2. *Magnetic field strength.* Stronger fields deflect a given beam more than weaker fields.
3. *Masses of the particles.* Because of their inertia, heavier particles are deflected less than lighter particles that carry the same charge.
4. *Charges on the particles.* Particles with higher charges interact more strongly with magnetic fields and are thus deflected more than particles of equal mass with smaller charges

The two last factors (mass of the ion and charge on the ion) are combined into the **mass/charge ratio**. Mass/charge ratio is given the symbol m/z (or sometimes m/e).

For example, if an ion had a mass of 28 and a charge of 1+, its mass/charge ratio would be 28. An ion with a mass of 56 and a charge of 2+ would also have a mass/charge ratio of 28.

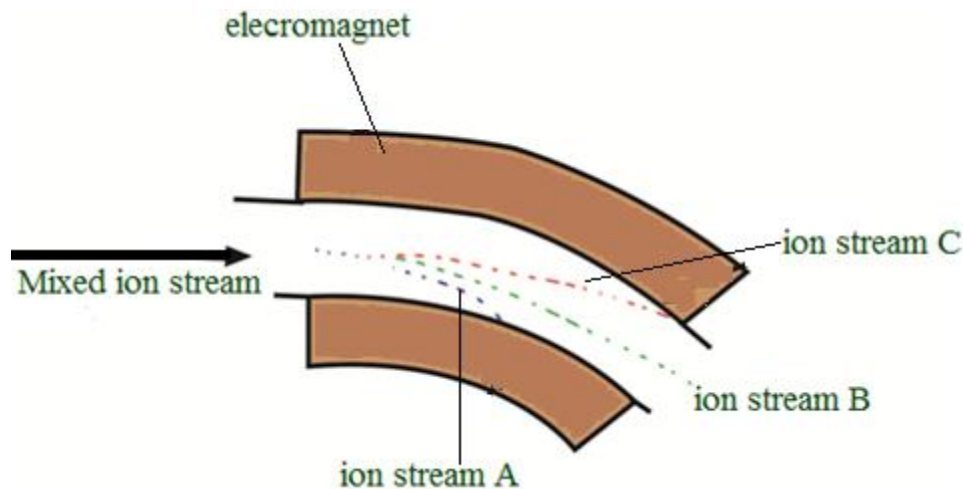

Figure 1.10: Magnetic field to separate positive ions of different m/z ratio

In the above diagram, ion stream A is most deflected: it will contain ions with the smallest mass/charge ratio. Ion stream C is the least deflected: it contains ions with the greatest mass/charge ratio. Assuming 1+ ions, stream A has the lightest ions, stream B the next lightest and stream C the heaviest. Lighter ions are going to be more deflected than heavy ones.

Stage 4: Detection

The beam of ions passing through the machine is detected electrically. As they pass out of the magnetic field, ions are *detected by an ion detector* which records the position of the ions on the screen and the number of ions that hit the screen at each position. These two pieces of information are used to produce a mass spectrum for the sample.

A flow of electrons in the wire is detected as an electric current which can be amplified and recorded. The more ions arriving, the greater the current.

Detecting the other ions

How might the other ions be detected (those in streams A and C which have been lost in the machine)?

Remember that stream A was most deflected. To bring them on to the detector, you would need to deflect them less by using a smaller magnetic field.

To bring those with a larger m/z value (the heavier ions if the charge is +1) on to the detector you would have to deflect them more by using a larger magnetic field.

If you vary the magnetic field, you can bring each ion stream in turn on to the detector to produce a current which is proportional to the number of ions arriving. The mass of each ion being detected is related to the size of the magnetic field used to bring it on to the detector. The machine can be calibrated to record current (which is a measure of the number of ions) against m/z directly. The mass is measured on the ^{12}C scale.

Note: The ^{12}C scale is a scale on which the ^{12}C isotope weighs exactly 12 units.

Recorder

The detector of a typical instrument consists of a counter which produces a current that is proportional to the number of ions which strike it. Through the use of electron multiplier circuits, this current can be measured so accurately that the current caused by just one ion striking the detector can be measured. The signal from the detector is fed to a **recorder, which produces the mass spectrum**. In modern instruments, the output of the detector is fed through an interface to a computer. The computer can store the data, provide the output in both tabular and graphic forms, and compare the data to standard spectra, which are contained in spectra libraries also stored in the computer.

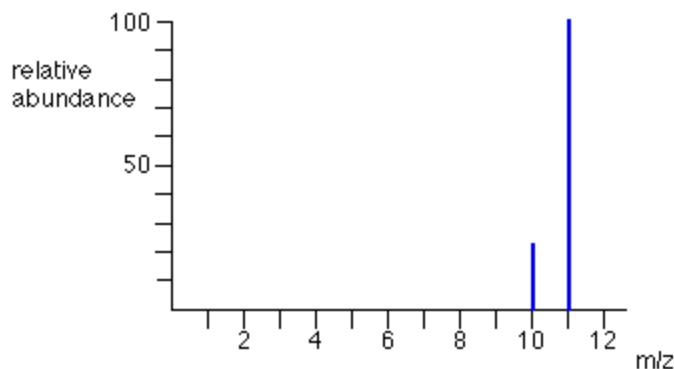

This is an example of an appearance of a mass spectrum of unknown element that has 2 isotopes.

Checking up 1.4

- Use the list of the words given below to fill in the blank spaces. Each word will be used once.

Vaporization chamber, mass spectrum, velocity, ionization, deflection, detector, acceleration

A sample of the element is placed in the _____ chamber where it is converted into gaseous atoms. The gaseous atoms are ionized by bombardment of high energy electrons emitted by a hot cathode to become positive ions (in practice, the voltage in the _____ chamber is set in such a way that only one electron is removed from each atom). The positive ions (with different masses) are then going faster to a high and constant _____ by two negatively charged plates: the process is called _____. The positive ions are then deviated by the magnet field. This process is called _____ (ions with smaller mass will be deflected more than the heavier ones). These ions are then detected by the ion _____. The information is fed into a computer which prints out the _____ of the element.

- The correct order for the basic features of a mass spectrometer is...
 - acceleration, deflection, detection, ionization
 - ionisation, acceleration, deflection, detection
 - acceleration, ionisation, deflection, detection
 - acceleration, deflection, ionisation, detection
- Which one of the following statements about ionisation in a mass spectrometer is incorrect?
 - gaseous atoms are ionised by bombarding them with high energy electrons
 - atoms are ionised so they can be accelerated
 - atoms are ionised so they can be deflected
 - it doesn't matter how much energy you use to ionise the atoms
- The path of ions after deflection depends on...

- A. only the mass of the ion
- B. only the charge on the ion
- C. both the charge and the mass of the ion
- D. neither the charge nor the mass of the ion

5. Which of the following species will be deflected to the greatest extent?

- A. $^{37}\text{Na}^+$
- B. $^{35}\text{Na}^+$
- C. ^{37}Na
- D. $^{35}\text{Na}^{2+}$

6. Which of the following separate the ions according to their mass-to-charge?

- a) Ion source
- b) Detector
- c) Magnetic sector
- d) Electric sector

1.5. Interpretation of mass spectra.

Activity 1.5. The mass spectrum of zirconium looks like this:

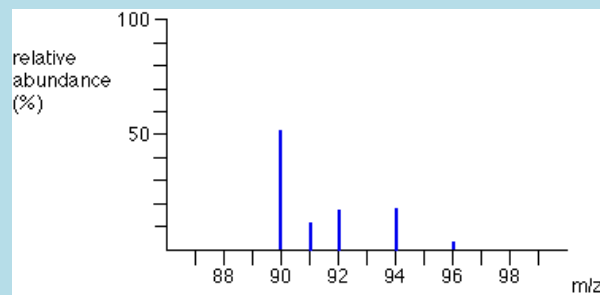

- a) What does m/z mean?
- b) Explain as fully as possible what the mass spectrum shows about zirconium. (I am not expecting you to read actual values from the relative abundance axis.)
- c) The spectrum shows lines for 1+ ions. If there were also peaks for 2+ ions, where would you expect to find them, and what would you predict about their heights relative to the 1+ peaks?

The mass spectrum of an element shows how you can find out the masses and relative abundances of the various isotopes of the element and use that information to calculate the relative atomic mass of the element.

Example 1: The mass spectrum of boron

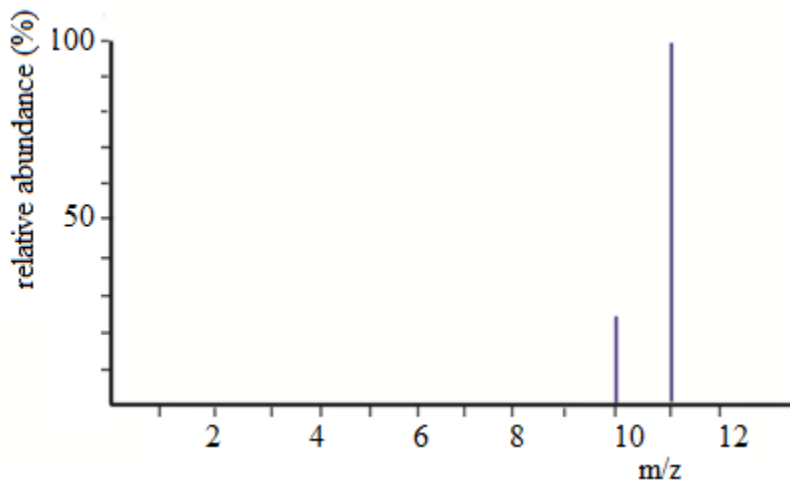

The mass spectrum of boron may be used to know the *number of boron isotopes* and *their relative abundances*

The two peaks in the mass spectrum shows that there are 2 isotopes of boron with relative isotopic masses of 10 and 11 on the ^{12}C scale

The relative size of the peaks gives you a direct measure of the relative abundances of the isotopes. The tallest peak is often given an arbitrary height of 100 but you may find all sorts of other scales used. It doesn't matter in the least.

You can find the relative abundances by measuring the lines on the stick diagram.

In this case, the two isotopes (with their relative abundances) are:

boron-10	23
boron-11	100

Example 2: The mass spectrum for zirconium

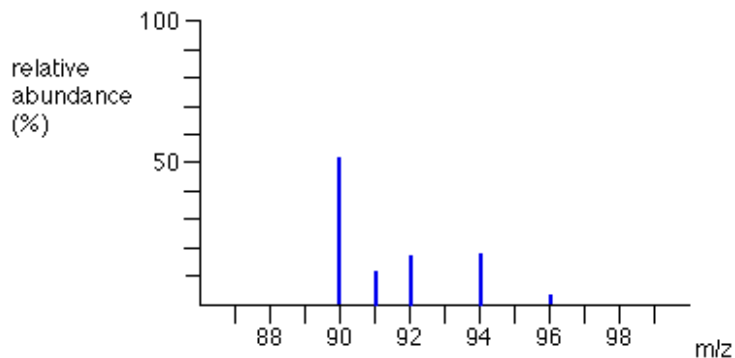

The mass spectrum of zirconium may be used to know *the number of zirconium isotopes* and *their relative abundances*

The 5 peaks in the mass spectrum show that there are 5 isotopes of zirconium with relative isotopic masses of 90, 91, 92, 94 and 96 on the ^{12}C scale.

This time, the relative abundances are given as percentages. Again you can find these relative abundances by measuring the lines on the stick diagram. In this case, the 5 isotopes (with their relative percentage abundances) are:

zirconium-90	51.5%	zirconium-92	17.1%	zirconium-96	2.8%
zirconium-91	11.2%	zirconium-94	17.4%		

Example 3: The mass spectrum of chlorine

Chlorine is taken as typical of elements with more than one atom per molecule. Chlorine has two isotopes, ^{35}Cl and ^{37}Cl , in the approximate ratio of 3 atoms of ^{35}Cl to 1 atom of ^{37}Cl . You might suppose that the mass spectrum would look like this:

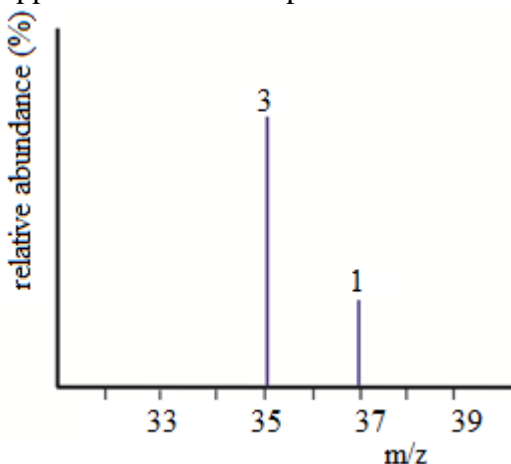

But it is not true. The problem is that chlorine consists of molecules, not individual atoms. When chlorine is passed into the ionization chamber, an electron is knocked off the molecule to give a **molecular ion**, Cl_2^+ . These ions won't be particularly stable, and some will fall apart to give a chlorine atom and a Cl^+ ion. The term for this is **fragmentation**.

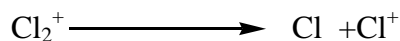

If the Cl_2^+ ion formed isn't then ionized in the ionization chamber, it simply gets lost in the machine (neither accelerated nor deflected).

The Cl^+ ions will pass through the machine and will give lines at 35 and 37, depending on the isotope and you would get exactly the pattern in the last diagram. The problem is that you will also record lines for the *unfragmented* Cl_2^+ ions.

At the end the spectrum will show peaks due to ionized atoms, Cl^+ at 35, and 37, and ionized molecule Cl_2^+ at 70, 72, 74 as below

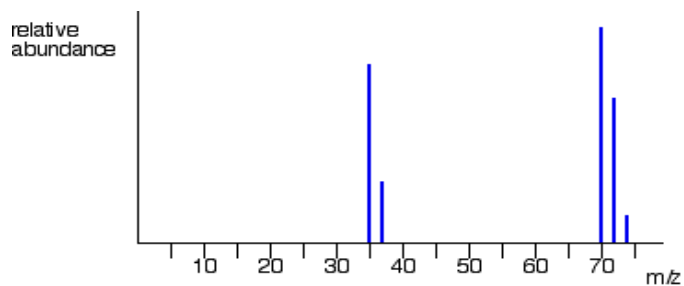

Checking up 1.5

The mass spectrum of magnesium is given below.

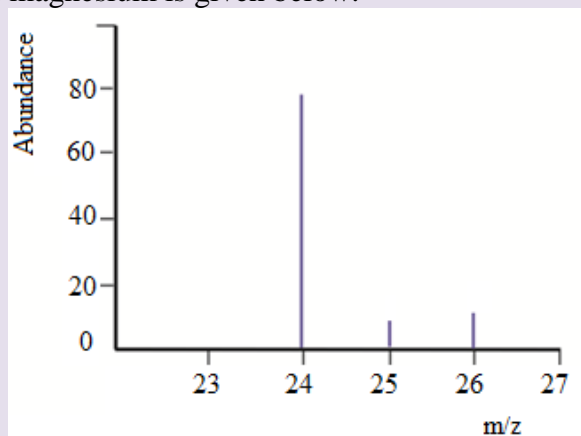

- How many isotopes does magnesium possess
- Estimate the isotopic mass of each of the magnesium isotopes
- Estimate the relative abundance for each of the isotopes of magnesium

1.6. Uses of the mass spectrometer and involving calculations

Activity 1.6

- Mass spectrometers are used to determine which of the following?
 - The atomic mass
 - Composition in sample
 - Concentration of elements in sample
 - Relative mass of atoms
- The mass spectrum of an element, A, contained four lines at mass/charge of 54, 56, 57, and

58 with relative intensities of 5.84:91.68:2.17:0.31 respectively. Explain these data and calculate the relative atomic mass of A

1.6.1. Uses of mass spectrometer

The following list shows the major mass spectrometric applications:

- Pharmaceutical: drug discovery, combinatorial chemistry, pharmacokinetics, drug metabolism.
- Clinical: neonatal screening, haemoglobin analysis, drug testing.
- Environmental: water quality, soil and groundwater contamination, food contamination, pesticides on foods.
- Geological: oil composition.
- Biotechnology: the analysis of proteins, peptides.

1.6.2. Calculation of RAM using mass spectrum

When the mass spectrum of the element is given, you can calculate the relative atomic mass of that element by using the information from the mass spectrum.

Example 1: the mass spectrum of boron is given below

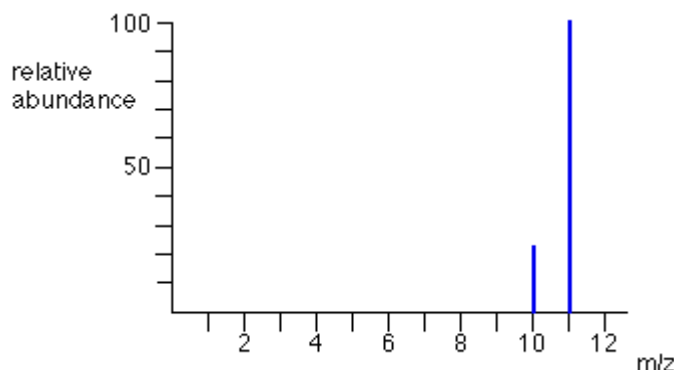

Determine the relative atomic mass of boron

From the mass spectrum given, we have 123 typical atoms of boron (sum of relative abundances). 23 of these would be ^{10}B and 100 would be ^{11}B .

The total mass of these would be $(23 \times 10) + (100 \times 11) = 1330$

The average mass of these 123 atoms would be $1330 / 123 = 10.8$ (to 3 significant figures).

10.8 is the relative atomic mass of boron.

Example 2: The figure below represents the mass spectrum of zirconium.

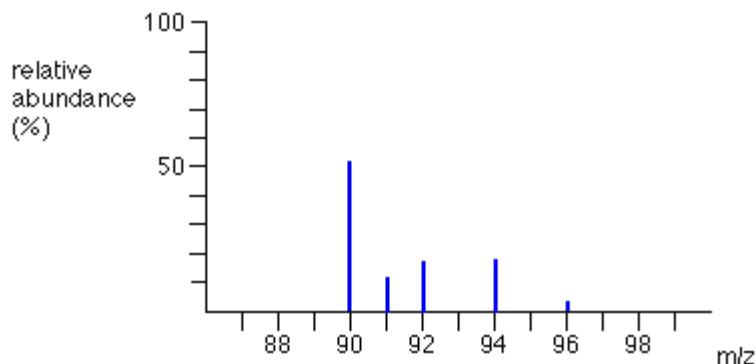

Suppose you had 100 typical atoms of zirconium (sum of relative abundances). 51.5 of these would be ^{90}Zr , 11.2 would be ^{91}Zr and so on. The total mass of these 100 typical atoms would be $(51.5 \times 90) + (11.2 \times 91) + (17.1 \times 92) + (17.4 \times 94) + (2.8 \times 96) = 9131.8$

The average mass of these 100 atoms would be $9131.8 / 100 = 91.3$ (to 3 significant figures).

91.3 is the relative atomic mass of zirconium.

Checking up 1.6

- Which of the following is not done through mass spectrometry?
 - Calculating the isotopic abundance of elements
 - Investigating the elemental composition of planets
 - Confirming the presence of O-H and C=O in organic compounds
 - Calculating the molecular mass of organic compounds
- Mass spectra enable you to find relative abundances of the isotopes of a particular element.
 - What are isotopes?
 - Define relative atomic mass.
 - The mass spectrum of strontium contains the following lines for 1+ ions:

m/z	% abundance
84	0.56
86	9.86
87	7.00
88	82.58

Calculate the relative atomic mass of strontium.

- The mass spectrum for chlorine looks like this:

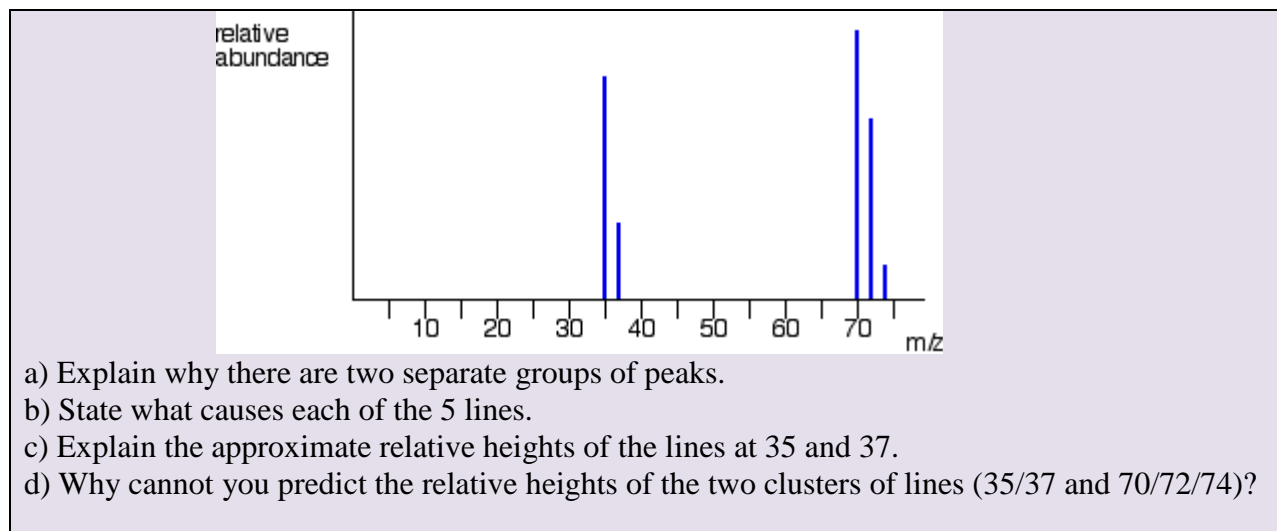

1.7. End unit assessment

I. Multiple choice questions

- Which of the following is true regarding a typical atom?
 - Neutrons and electrons have the same mass.
 - The mass of neutrons is much less than that of electrons.
 - Neutrons and protons together make the nucleus electrically neutral.
 - Protons are more massive than electrons
- Which of the following statements is(are) *true*? For the false statements, correct them.
 - All particles in the nucleus of an atom are charged.
 - The atom is best described as a uniform sphere of matter in which electrons are embedded.
 - The mass of the nucleus is only a very small fraction of the mass of the entire atom.
 - The volume of the nucleus is only a very small fraction of the total volume of the atom.
 - The number of neutrons in a neutral atom must equal the number of electrons.
- Each of the following statements is true, but Dalton might have had trouble explaining some of them with his atomic theory. Give explanations for the following statements.
 - Atoms can be broken down into smaller particles.
 - One sample of lithium hydride is 87.4% lithium by mass, while another sample of lithium hydride is 74.9% lithium by mass. However, the two samples have the same chemical properties
- In mass spectrometer, the sample that has to be analysed is bombarded with which of the following?
 - Protons
 - Electrons
 - Neutrons

D. Alpha particles

5. Mass spectrometer separates ions on the basis of which of the following?
- A. Mass
 - B. Charge
 - C. Molecular weight
 - D. Mass to charge ratio
6. In a mass spectrometer, the ions are sorted out in which of the following ways?
- A. By accelerating them through electric field
 - B. By accelerating them through magnetic field
 - C. By accelerating them through electric and magnetic field
 - D. By applying a high voltage
7. The procedure for mass spectroscopy starts with which of the following processes?
- A. The sample is bombarded by electron beam
 - B. The ions are separated by passing them into electric and magnetic field
 - C. The sample is converted into gaseous state
 - D. The ions are detected
8. Which of the following ions pass through the slit and reach the collecting plate?
- A. Negative ions of all masses
 - B. Positive ions of all masses
 - C. Negative ions of specific mass
 - D. Positive ions of specific mass
9. Which of the following statements is not true about mass spectrometry?
- A. Impurities of masses different from the one being analysed interferes with the result
 - B. It has great sensitivity
 - C. It is suitable for data storage
 - D. It is suitable for library retrieval
10. In a mass spectrometer, the sample gas is introduced into the highly evacuated spectrometer tube and it is ionised by the electron beam.
- A. True

B. False

II. Short and long answer questions

11. What are the three fundamental particles from which atoms are built? What are their electric charges? Which of these particles constitute the nucleus of an atom? Which is the least massive particle of the fundamental particles?
12. Verify that the atomic weight of lithium is 6.94, given the following information:
 ${}^6\text{Li}$, mass = 6.015121 u; percent abundance = 7.50%
 ${}^7\text{Li}$, mass = 7.016003 u; percent abundance = 92.50%
13. The diagram below shows the main parts of a mass spectrometer.

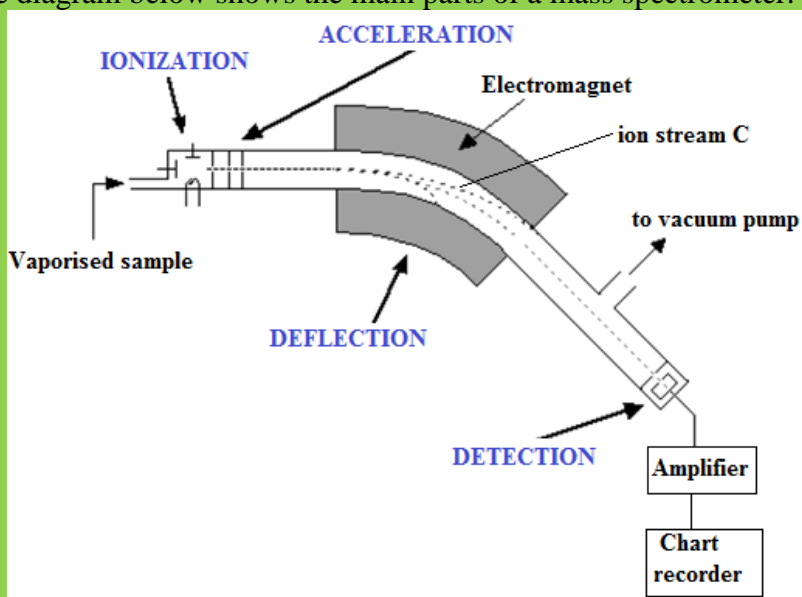

- (a) Describe the different steps involved in taking a mass spectrum of a sample
 - (b) (i) Which two properties of the ions determine how much they are deflected by the magnetic field? What effect does each of these properties have on the extent of deflection?
(ii) Of the three different ion streams in the diagram above, why is the ion stream C least deflected?
(iii) What would you have to do to focus the ion stream C on the detector?
 - (c) Why is it important that there is a vacuum in the instrument?
 - (d) Describe briefly how the detector works.
14. A mass spectrum of a sample of indium shows two peaks at $m/z = 113$ and $m/z = 115$. The relative atomic mass of indium is 114.5. Calculate the relative abundances of these two isotopes. (b) The mass spectrum of the sample of magnesium contains three peaks with the mass-to-charge ratios and relative intensities shown below
- (i) Explain why magnesium gives three peaks in mass spectrum?

m/z	24	25	26
relative intensities	1	0.127	0.139

(ii) Use the information in the table above to calculate the accurate value for the relative atomic mass of magnesium

17. There exists 3 isotopes of oxygen that occur naturally with atomic mass 16, 17 and 18 with abundance 99.1% ; 0.89% and 0.01% respectively. Given that oxygen occurs naturally as diatomic molecule,

(a) Predict the number of peaks that will be observed on the screen of mass spectrometer.

(b) Show the molecular ions that are responsible of these peaks.

UNIT 2: ELECTRONIC CONFIGURATION OF ATOMS AND IONS

Key unit Competence

To relate Bohr's atomic model with atomic spectrum of Hydrogen, write electronic configuration of atoms and ions using s, p, d and f atomic orbitals and interpret graphical information related to ionization energy of elements.

Learning objectives

By the end of this unit, I will be able to:

- Explain the stability of atoms using the concept of quantization of energy.
- Explain the achievements and limitations of Bohr's atomic model.
- Explain the existence of energy levels using the data from emission spectra.
- Describe Hydrogen spectral lines and spectral line series
- Explain the types of spectra in relation with the nature of light
- Explain the quantum theory of the atom using the quantum numbers.
- Determine the number and shapes of orbitals in given level or principal quantum number
- Explain the Rules governing the electronic configuration: Aufbau principle and Hund's rule
- Explain the relationship between the electronic configuration and the stability of the atoms
- Interpret the graphs of first ionisation energy against the atomic number.
- Describe the factors which influence the first ionisation energy.

Introductory Activity 2



Fig. 2.1(a) Variation of potential energy up ramp Fig.2.1(b) Variation of potential energy up steps

Observe the image above. In your groups discuss and find answers to the following questions.

1. What can you see on the image above?

2. What type of motion is performed by the people on the image?
3. How does their potential energy change?

2.1. Bohr's atomic model and concept of energy levels

The potential energy of a person walking up a ramp increases in a uniform and continuous manner, whereas the potential energy of a person walking up steps increases in a stepwise and quantized manner. This can be explained by the values of energy which are continuous for the person walking up a ramp while they are discrete for the person walking up steps (**Figure 2.1(a)** and **Figure 2.1(b)**).

Niels Bohr (1885-1962), a young Danish physicist working in Rutherford's laboratory, suggested a model for the hydrogen atom and predicted the existence of line spectra. In his model, based on Planck's and Einstein's ideas about quantized energy, Bohr proposed three postulates:

- An electron can rotate around the nucleus in certain fixed orbits of definite energy without emission of any radiant energy. Such orbits are called stationary orbits.
- An atom can make a transition from its stationary state of higher energy E_2 to a state of lower energy E_1 and emit a single photon of frequency ν . Conversely, an atom can absorb an energy at the lower level E_1 and transit to the higher energy level E_2 . That is, the change in energy for a system ΔE which can be represented by the equation:

$$\Delta E = nh\nu \text{ or } \nu = \frac{E_2 - E_1}{h} \text{ where } n \text{ is an integer } (1, 2, 3, \dots) \text{ and } h \text{ is Planck's constant}$$

determined from experiment and has a value of $6.626 \times 10^{-34} \text{ J}\cdot\text{s}$; ν is the frequency of the electromagnetic radiation absorbed or emitted. Each of these small "packets" of energy is called a quantum. Energy can be gained or lost only in whole-number multiples of the quantity $h\nu$,

That is, the change in energy for a system can be represented by the equation:

$$\Delta E = nh\nu, \text{ where } n \text{ is an integer } (1, 2, 3, \dots).$$

An atom does not release energy when it is in one of its stationary states. That is, the atom does not change energy while the electron moves on a given orbit.

When an electron on the given orbit absorbs an appropriate quantum of energy, it jumps, i.e. is promoted to a higher energy orbit; this process is called "**excitation**" of electron. On the contrary, if the electron loses an appropriate quantum of energy, it falls on the lower energy orbit by emission of a light corresponding to the lost quantum of energy and the process is called "**de-excitation**" of electron. As there are many energy levels on which electrons can be excited and de-excited, an atom will have many lines of absorption, each corresponding to a quantum of energy absorbed: this appears as a series of lines called **absorption spectrum**. In the same way the series of emission lines will produce an **emission spectrum**.

2.1.1. Achievements of Bohr's Atomic Model

- ***Explanation of the stability of an atom***
Based on Rutherford's atomic model, the electrons move around the nucleus in circular paths called orbits. According to the classical theory of electromagnetism, a charged particle revolving around a charged nucleus would release energy and end up by spiraling into the nucleus; thus the atoms would be unstable. The Bohr's atomic model explains why an atom is stable.
- ***Explanation of the production of the absorption and emission spectra***
The Bohr's atomic model explains the origin of atomic absorption and emission spectra.

2.1.2. Limitations of Bohr Model

1. Bohr's theory fails to explain the origin of the spectral lines of multi-electron atoms.

It only explains the origin of the spectrum of hydrogen-like species having only one electron such as $H, He^+, Li^{2+}, Be^{3+}, \dots$

The model fails to explain the spectral lines of atoms or species with more than one electron.

2. according to Bohr, the circular orbits in which electrons revolve are planar. However, modern research has shown that an electron moves around the nucleus in the three dimensional space.

3. Bohr's theory fails to account for Zeeman Effect and Stark Effect. ***Zeeman Effect*** is the splitting of the spectral lines into thinner and closely-spaced lines when an excited atom is placed in a magnetic field. ***Stark Effect*** consists of the splitting of the spectral lines into thinner and closely-spaced lines in presence of electric field.

4. Bohr's theory is in contradiction with Heisenberg's uncertainty principle. Bohr assumes that the electron revolves around the nucleus in circular orbits at fixed distance from the nucleus and with a fixed velocity. Bohr's assumption was that the electron revolves around the nucleus in circular orbits situated at precise distance and with fixed velocity. However, according to W. Heisenberg, it is not possible to know simultaneously the accurate position and the velocity of a particle.

Checking up 2.1

1. Find out two more examples illustrating the concept of quantization.
2. Discuss the main weakness of Rutherford's nuclear atom.

2.2. Hydrogen spectrum and spectral lines

Activity 2.2

Look at the picture of neon tube light below and do research about how this neon tube light work to produce light and present your findings

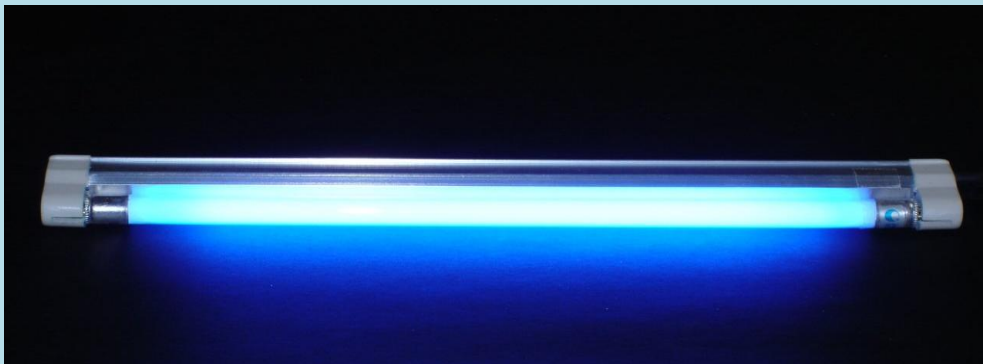

(Source: <https://www.amazon.com/Blue-Replacement-Light-Purchased-Length/dp/B00AWPI2F8>)

Bohr's atomic model allows explaining the emission spectra of atoms. This happens when excited electrons lose energy in form of electromagnetic radiation and transit to lower energy levels. The understanding of the nature of light allows explaining a number of phenomena including the occurrence of emission and absorption spectra of atoms.

The wave-particle nature of the light

A. Light as a wave

The light is a wave-like phenomenon as shown in Figure 2.2.

It is characterized by its wave length, generally symbolized by the Greek letter lambda, λ , and its frequency, represented by the Greek letter nu¹, ν .

As shown in the Figure below, the wavelength represents the distance between two successive summits/peaks (or two successive troughs). The frequency represents the number of complete wavelengths made by the light per second, also called cycles per second.

Visible light is composed by different visible lights with different λ and ν .

But all those lights have the same speed, the speed of light, which, in a vacuum, is equal to: 3.00×10^8 m/s.

Although different types of light have different λ and ν , they move at the same speed c .

This results in the relation between the speed of light and its wavelength and frequency:

$$c = \lambda \nu$$

From this relation, and since c is constant, we can conclude that:

- Light with long wavelength has low frequency, whereas
- Lights with short wavelength has high frequency.

¹ The letter gamma, γ , may also be used.

Let's take an example to illustrate: light₁ has λ_1 equal to 10^5 m whereas light₂ has λ_2 equal to 10^{-5} m. After 1 second, both would have travelled 3.00×10^8 m, the speed of light, but their frequencies will be different:

$$v_1 = c/\lambda_1 = 3.00 \times 10^8 \text{ms}^{-1} / 10^5 \text{m} = 3.00 \times 10^3 \text{s}^{-1} = 3,000 \text{ cycles/s}$$

$$v_2 = c/\lambda_2 = 3.00 \times 10^8 \text{ms}^{-1} / 10^{-5} \text{m} = 3.00 \times 10^{13} \text{s}^{-1} = 30,000,000,000,000 \text{ cycles/s}$$

Light is energy, represented by: $E = h\nu$ where h is Plank's constant.

Hence energy in the light is proportional to its frequency; higher the frequency of the light, higher is its energy and vice-versa.

The different colors of the visible light differ by their wavelength as shown in the Figure 2.3.

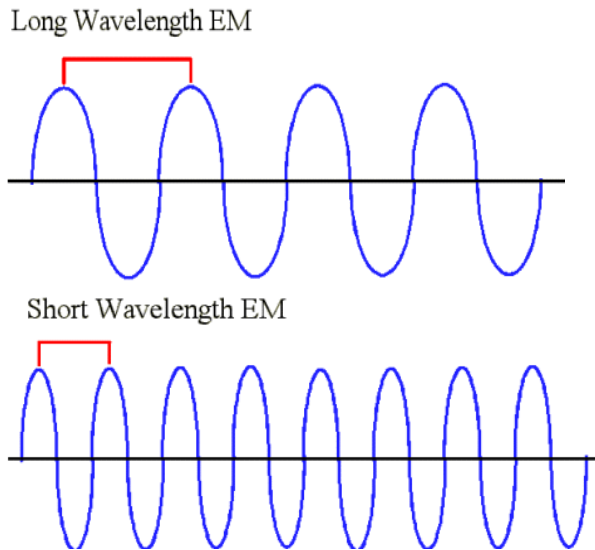

Figure 2.2: Wave-like phenomenon

As illustrated in **Figure 2.2** below, the right side of the spectrum consists of high-energy, high-frequency and low-wavelength radiations. Conversely, the left side consists of low-energy, low-frequency and high-wavelength radiations.

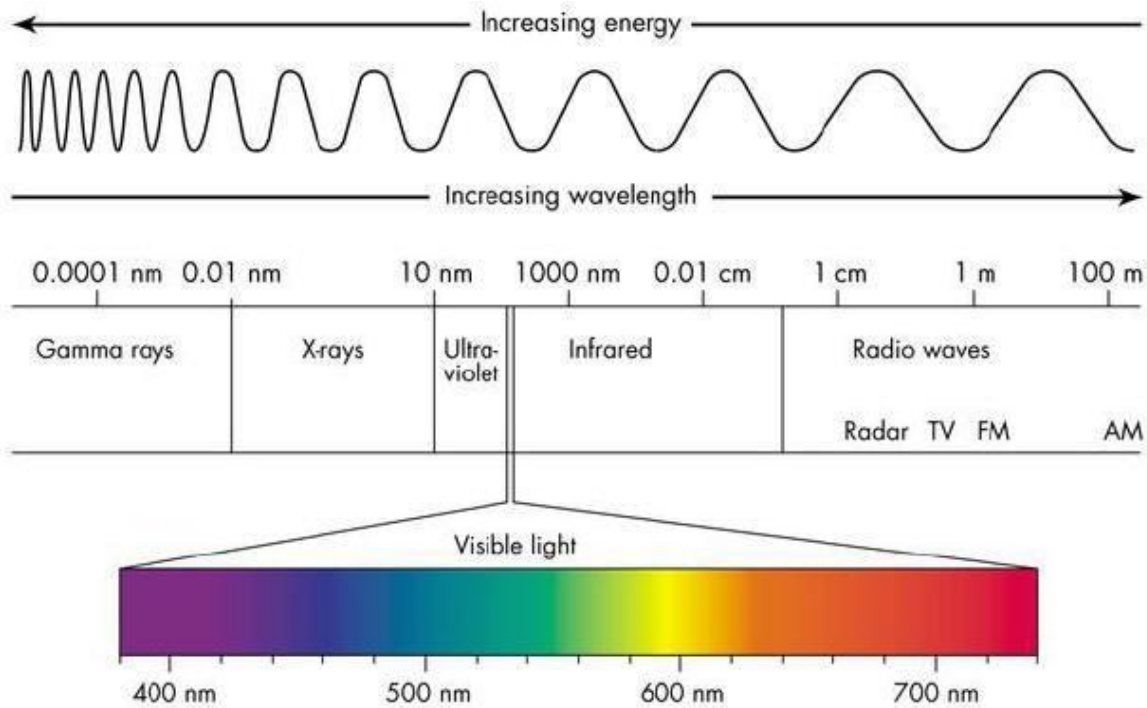

Figure 2.3: Electromagnetic radiation

When an electron is excited or de-excited, the energy absorbed or emitted corresponds to the difference of energy, ΔE , between the final energy level of the electron, E_2 , and the starting energy level of the electron, E_1 : $E_2 - E_1 = \Delta E = h\nu$. ΔE is positive when $E_2 > E_1$, this is the case of absorption and excitation of electron; on the other hand ΔE may be negative when $E_2 < E_1$, in case of emission and de-excitation of electron.

Figure 2.4 below shows the different series of emission spectra of hydrogen. As you can see, the difference between those series is the final energy level where the electron fall after de-excitation.

The series have been named according to the scientists who discovered them.

Ionization of an atom or loss of an electron corresponds to excitation of an electron to the level $n = \infty$.

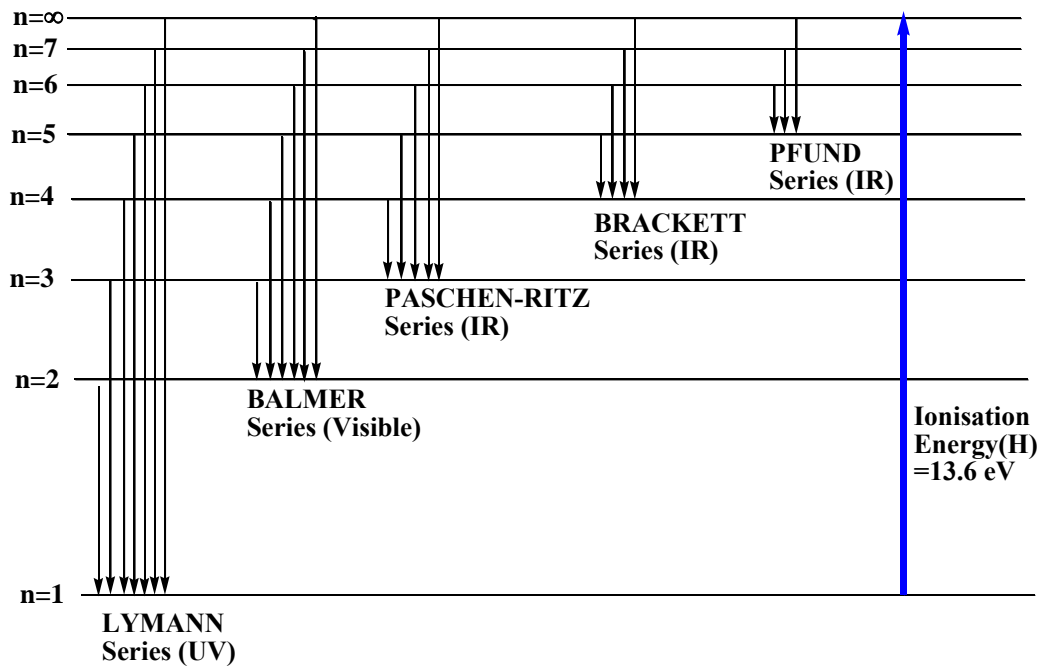

Figure 2.4: Energy-Level diagram for the hydrogen atom.

Checking up 2.2

1. What is the significance of infinity level in the hydrogen spectral lines?
2. Draw a would be hydrogen absorption spectra series
3. Compare Balmer series to Bracket series; which one bears more energy? Explain

2.3. Atomic spectra

Activity 2.3



Observe the picture above, discuss in groups and answer the following questions.

- (a) What do you see on the above photo?
- (b) State the physical phenomenon which is related to the above photo.
- (c) Think of any other means of producing the same pattern. List two of them.
- (d) What property can you attribute to light with reference to the above process?

Checking up 2.3

1. Different metals, when exposed to a flame, emit different flame colors. Explain the origin of that difference.
2. Would you expect to see the emission rays and the absorption rays of a given element to appear at the same place of a photographic plate or not. Explain your answer.
3. How do you explain the many spectral rays for the same element?
 - a.

2.4 Quantum Numbers

Activity 2.4

1. a) Write the electronic configuration of aluminium atom ($Z=13$)
- b) Indicate the number of electrons in each energy level/quantum shell
- c) The shells are numbered from inside-outward starting from 1, 2, 3, 4 ... which other name is given to these shells?
- d) How did you obtain the exact number of electrons in each energy level/quantum shell in (c) above?

An atom is composed three particles such as protons, electrons and neutrons. In atoms, the electrons occupy a range of different orbitals. Each orbital is specified by interrelated **quantum numbers**. Quantum numbers are numbers used to describe the energetic situation of an atom. Three quantum numbers can be distinguished and each is characterized by its value and is represented by a letter.

1) The principal quantum number (n) is a positive integer which **varies from 1 to ∞** . The principal quantum number specifies the energy level of the atom: the higher the n value, the higher the energy level. When the electron occupies an orbital with $n = 1$, the atom is in its ground state and has lower energy than when the electron occupies the $n = 2$. The shells (values of n) can be represented by the letters **K, L, M, N, O, P**.

In the Bohr's atomic model, K, L, M, ... were used to represent different orbits or shells of electrons. Later on, the term **shells** sometimes is used to describe a group of orbitals with the same principal quantum number. The term **subshell** describes a group of orbitals with the same principal and second quantum number. The maximum number of orbitals and electrons that can be found in an energy level **n** are **n^2** and **$2n^2$** , respectively (Table 2.1). The maximum number of sub shells in an energy level n equals **n**.

Table 2.1 Relation between the principal quantum number, the number of orbitals and the maximum number of electrons.

n	Maximum Number of subshells	Maximum Number of orbitals	Maximum Number of electrons
1	1	1	2
2	2	4	8
3	3	9	18
4	4	16	32

The modern atomic model is based on a concept developed by a Schrodinger. In this model, an electron cannot be located with precision around the nucleus. Only the high probability of finding an electrons in a certain region around can be estimated. The regions around the nucleus where there is high probability of finding the electron, more than 95%, are called "orbitals".

An orbital is defined by 3 quantum numbers: the principal quantum number (n), the angular momentum quantum number (l), and the magnetic quantum number (m_l). There is a 4th quantum number related to the electron, the spin, represented by S.

2)The **angular momentum quantum number (l)** is an integer which zero or higher but less than n-1, i.e. equal to: 0,1, 2, 3,...up to n-1. It is also called *secondary* or *azimuthal* quantum number. It indicates the shape of the orbital and is sometimes called the orbital shape quantum number. The table 2.2 relates the principal quantum number, the angular momentum quantum number and the magnetic quantum number. There are traditional names given to some values of l: 0 = s, 1 = p, 2 = d, 3 = f

3). Magnetic quantum number (m_l)

The magnetic quantum number describes the orientation of the orbital. It is an integer that **varies from -l to +l**. For each value of l there are $(2l + 1)$ values of m_l corresponding to $(2l + 1)$ orientations under the influence of magnetic field.

Table 2.2 Number of orbitals for a given angular momentum l

n	l	Type of orbitals	m_l	Number of orbitals
1	0	s	0	1
2	0, 1	s, p	(0); (-1, 0, 1)	4
3	0,1, 2	s, p, d	(0);(-1, 0, 1);(-2, -1, 0, 1, 2)	9
4	0,1,2, 3	s, p, d, f	(0);(-1, 0, 1);(-2, -1, 0, 1, 2); (-3, -2, -1, 0, 1, 2, 3)	16

The table 2.2 shows that, apart s sub-level that has only one orbital, other sub-levels have a certain number of different orbitals; those orbitals have the same energy but differ in their specific orientations. Example p orbitals are 3 with different special orientations: $p_x p_y p_z$.

Shapes of orbitals:

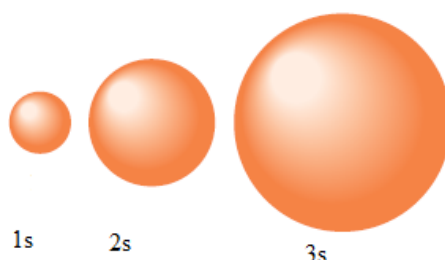

Figure 2.10: Representation of s orbitals (Source: Zumdahl S.& Zumdahl A., 2007)

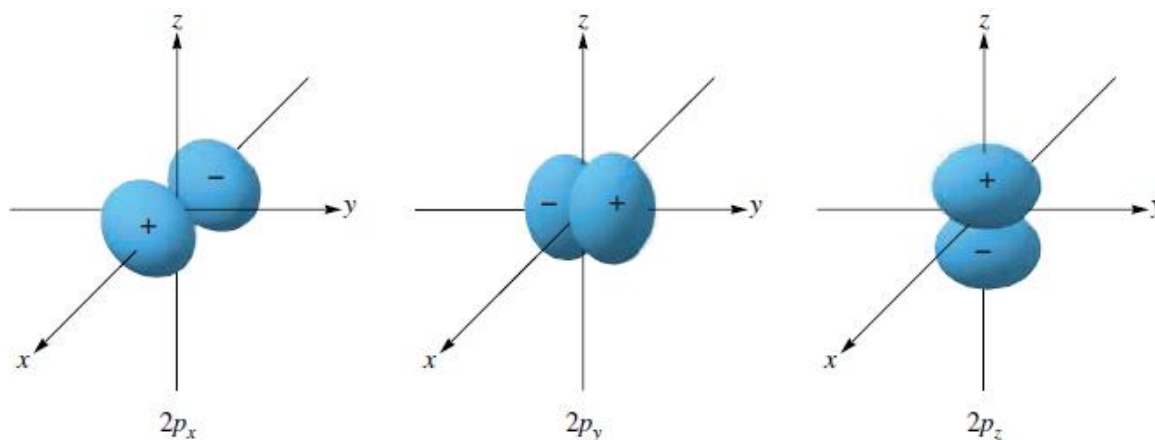

Figure 2.11: Representation of p orbitals (Source: Zumdahl S.&Zumdahl A., 2007)

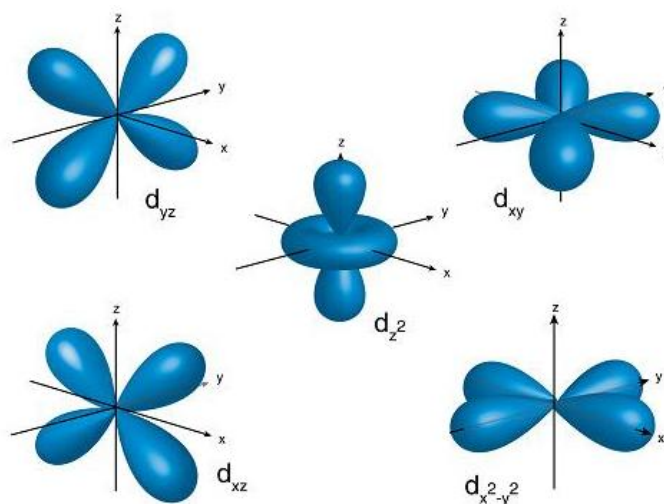

Figure 2.12: Representation of f orbitals

4) The spin quantum number

The fourth quantum number is the spin quantum number, represented with m_s .

This number describes ***the spinning direction of the electron in a magnetic field. The direction could be either clockwise or counterclockwise.*** The electron behaves as if it were spinning about its axis, thereby generating a magnetic field whose direction depends on the direction of spin. The two directions for the magnetic field correspond to the two possible values for the spin quantum number, m_s . Since only two values are allowed $m_s = +\frac{1}{2}$ or $m_s = -\frac{1}{2}$ as shown in the **Figure 2.13**.

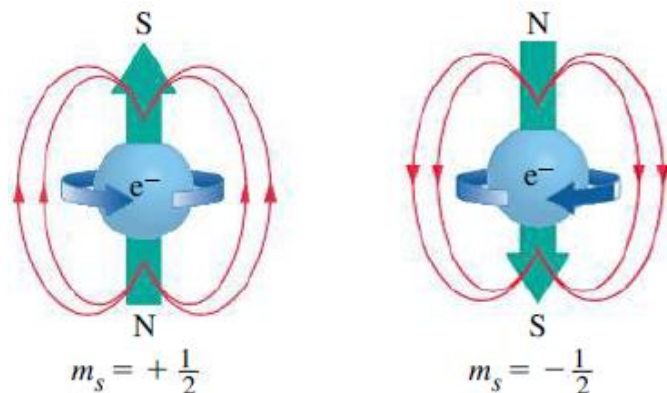

Figure 2.13: Electron spin (Source: Petrucci et al., 2011)

Each orbital can contain a maximum of two electrons with opposite spins. The electrons with $s = +\frac{1}{2}$ are called spin-up while those with $s = -\frac{1}{2}$ are called spin down.

$m_s = +\frac{1}{2}$ and $m_s = -\frac{1}{2}$ are often represented as $\boxed{\uparrow}$ and $\boxed{\downarrow}$, respectively.

Checkup 2.4

Which of the following sets of quantum numbers are not allowed? For each incorrect set, state why it is incorrect.

- a. $n = 3, l = 3, m_l = 0, m_s = -\frac{1}{2}$
- b. $n = 4, l = 3, m_l = 2, m_s = -\frac{1}{2}$
- c. $n = 4, l = 1, m_l = 1, m_s = +\frac{1}{2}$
- d. $n = 2, l = 1, m_l = -1, m_s = -1$
- e. $n = 5, l = -4, m_l = 2, m_s = +\frac{1}{2}$
- f. $n = 3, l = 1, m_l = 2, m_s = -\frac{1}{2}$

2.5 Electronic configuration of atoms and ions

Activity 2.5

1. Write the electronic structure of the following chemical species
K ($Z=19$), Ne ($Z=10$), Al^{3+} ($Z=13$), Cl ($Z=17$), O^{2-} ($Z=16$)
2. Using information in question 1,
 - a. Determine the group and period of K and Cl.
 - B. Which species have a stable electronic configuration? Explain.

The electron configuration is the distribution of electrons of an atom in its atomic orbitals. The electronic configuration of an atom is governed by three main rules.

1) Aufbau Principle

The Aufbau principle explains how to build the electronic configuration of an atom. The Aufbau principle states that atomic orbitals of lower energy must be filled before the higher energy orbital. The Aufbau principle is sometimes referred to as the “building-up” principle. Figure 2.5 is a useful and simple aid for keeping track of the order in which electrons are first filled for each atomic orbital. The different orbitals are filled in the order *1s, 2s, 2p, 3s, 3p, 4s, 3d, 4p, 5s, 4d, 5p, 6s, 4f, 5d, 6p, 7s, 5f, 6d, 7p*.

Notice that as energy levels increase starting from $n=3$, 4s orbital is filled before 3d, 5s before 4d, etc... as shown in the diagram below. But when ionized, 4s electrons are ionized before 3d, and 5s before 4d.

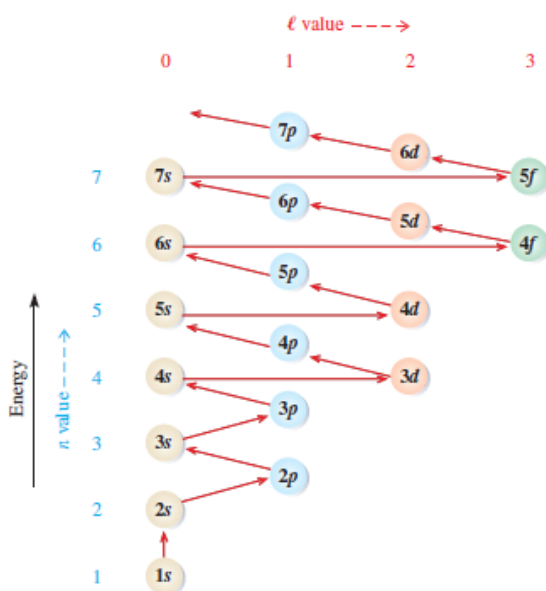

Figure 2.14: The order of filling orbitals with electrons

2) Pauli Exclusion Principle

This principle states that in an atom, *two electrons cannot have the same four quantum numbers* n , l , m_l , and m_s as an orbital can contain a maximum of only two electrons, the two electrons must have opposing spins.

3) Hund's rule states that orbitals of equal energy are each occupied by one electron before electrons begin to pair up into the same orbital. All the unpaired electrons must have the same spin. A slight preference for keeping electrons in separate orbitals helps to minimize the natural repulsive forces that exist between two electrons.

When building the electronic configuration of elements, you must be guided by the principles and rules seen above and: writing the principal quantum number in Arabic number, followed by the orbitals immediately followed by the number of electrons in the orbital as superscript.

An atom X: $1s^2$: has only two electrons in s orbital at the 1st energy level

An atom Y: $1s^2 2s^2 2p^3$: has electrons in 2 levels of energy: level $n=1$, and level $n=2$. In level 1, it has 2 electrons in s orbital. In level 2, it has 2 electrons in s orbital and 3 electrons in p orbitals.

Checkup 2.5 (a)

1. Build the electronic configuration of the following atoms: ${}_1\text{H}$, ${}_3\text{Li}$, ${}_5\text{B}$, ${}_{11}\text{Na}$, ${}_{18}\text{Ar}$, ${}_{19}\text{K}$, ${}_{21}\text{Sc}$, ${}_{24}\text{Cr}$, ${}_{26}\text{Fe}$, ${}_{29}\text{Cu}$

2. Write the electronic configuration for each of the following pairs of ions. State the more stable ion in gaseous state and explain your choice.

a) Cu^+ and Cu^{2+}

b) Fe^{2+} and Fe^{3+}

Expanded notation

Expanded notation is another method of writing the s, p, d and f notation. The method uses the same concept as s, p, d and f notation except that each individual orbital of a sub-level having many orbitals is represented with a subscript letter indicating the orientation of the orbital. This applies for p, d, and f orbitals.

Considering that p-orbital has three components p_x , p_y and p_z the expanded electronic configuration of some elements is given hereafter.

1) H ($Z=2$): $1s^1$

2) He ($Z=3$): $1s^2$

3) Li ($Z=3$): $1s^2 2s^1$

4) Be ($Z=4$): $1s^2 2s^2$

5) B ($Z=5$): $1s^2 2s^2 2p_x^1$

6) C ($Z=6$): $1s^2 2s^2 2p_x^1 2p_y^1$

7) N ($Z=7$): $1s^2 2s^2 2p_x^1 2p_y^1 2p_z^1$

- 8) O (Z=8): $1s^2 2s^2 2p_x^2 2p_y^1 2p_z^1$
 9) F(Z=9): $1s^2 2s^2 2p_x^2 2p_y^2 2p_z^1$
 10) Ne(Z=10): $1s^2 2s^2 2p_x^2 2p_y^2 2p_z^2$
 11) Al^{3+} (Z = 13): $1s^2 2p_x^2 p_y^2 p_z^2$
 12) S^{2-} (Z = 16): $1s^2 2s^2 2p_x^2 p_y^2 p_z^2 3s^2 3p^6$

Checkup 2.5 (b)

Write the expanded electronic configuration for each of the following atom/ions.
 S (z=16), P^{3-} (z=15), Mg^{2+} (z=12)

Orbital representation

An orbital box representation consists of a box for each orbital in a given energy level, grouped by sublevel, with an arrow indicating an electron and its spin.

Note that two electrons in the same orbital have necessarily opposite spins as indicated in the examples below.

The table 2.4 shows the electronic configuration of some elements using orbital box representation and applying Hund's rule.

Examples

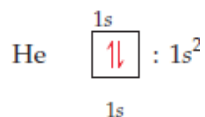

Table 2.4: Electronic configuration using orbital box representation

Element	Total electrons	Orbital diagram						
		1s	2s	2p			3s	
Li	3	$\boxed{\uparrow\downarrow}$	$\boxed{\uparrow}$	$\boxed{}$	$\boxed{}$	$\boxed{}$	$\boxed{}$	$\boxed{}$
Be	4	$\boxed{\uparrow\downarrow}$	$\boxed{\uparrow\downarrow}$	$\boxed{}$	$\boxed{}$	$\boxed{}$	$\boxed{}$	$\boxed{}$
B	5	$\boxed{\uparrow\downarrow}$	$\boxed{\uparrow\downarrow}$	$\boxed{\uparrow}$	$\boxed{}$	$\boxed{}$	$\boxed{}$	$\boxed{}$
C	6	$\boxed{\uparrow\downarrow}$	$\boxed{\uparrow\downarrow}$	$\boxed{\uparrow}$	$\boxed{\uparrow}$	$\boxed{}$	$\boxed{}$	$\boxed{}$
N	7	$\boxed{\uparrow\downarrow}$	$\boxed{\uparrow\downarrow}$	$\boxed{\uparrow}$	$\boxed{\uparrow}$	$\boxed{\uparrow}$	$\boxed{}$	$\boxed{}$
Ne	10	$\boxed{\uparrow\downarrow}$	$\boxed{\uparrow\downarrow}$	$\boxed{\uparrow\downarrow}$	$\boxed{\uparrow\downarrow}$	$\boxed{\uparrow\downarrow}$	$\boxed{}$	$\boxed{}$
Na	11	$\boxed{\uparrow\downarrow}$	$\boxed{\uparrow\downarrow}$	$\boxed{\uparrow\downarrow}$	$\boxed{\uparrow\downarrow}$	$\boxed{\uparrow\downarrow}$	$\boxed{}$	$\boxed{\uparrow}$

Checkpoint 2.5

Using boxes to represent orbitals, draw the electronic configuration of N^{3-} ($z=7$), Ti^{4+} ($z=22$), Mg^{2+} ($z=12$), Ar ($z=18$)

Identify the isoelectronic species that are present.

Noble Gas Notation

All noble gases have completely filled subshells and can be used as a shorthand way of writing electron configurations for subsequent atoms.

When using this method, the following steps are respected.

- Identify the noble gas whose electronic configuration is included in that of the concerned element.
- Write the chemical symbol of the identified noble gas within square brackets. We call this the noble gas core.
- Add electrons beyond the noble gas core. Note that electrons that are added to the electronic level of the highest principal quantum number (the outermost level or valence shell) are called **valence electrons**.

Example: Given the electronic configurations of the noble gases Ne and Ar, one can write the electronic configuration of some elements in noble gas notation of some elements as:

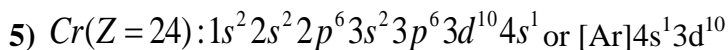
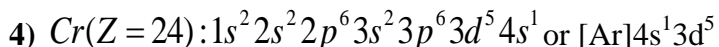
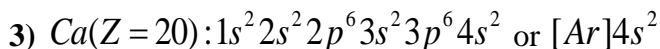
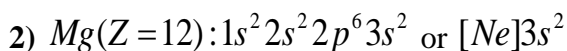
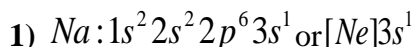
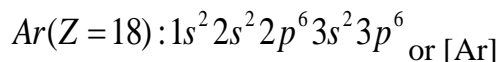
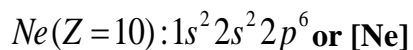

Checking up 2.5 (d)

Using the noble gas notation, write the electronic configuration of the following atoms/ions.

- Ge ($Z=32$)
- S ($Z=16$)
- Co^{2+} ($Z=27$)
- Br^- ($Z=35$)
- Sr ($Z=38$)

2.6. Relationship between ionization energy, energy levels and factors influencing ionization energy

Activity 2.6

1. Write the electronic configuration of the following elements/ions use s, p, d, ...)
Sodium, magnesium, magnesium ion, aluminium, aluminium ion, oxygen ion
2. Identify the common feature possessed by ions in (1) and why do they have such feature
3. Suggest what happened to aluminium atom when it changed to aluminium ion
4. Identify the group and the period of aluminium, sodium and oxygen atom

2.6.1. Concept of Ionization energy

The ionization energy is a measure of the energy needed for an atom, in gaseous state, to lose an electron and become positive ion.

The first ionisation energy is the energy required to remove one electron from an atom in its gaseous state. The example below shows how to represent the successive ionization energies of an atom M.

First ionisation energy: $M(g) \rightarrow M^+(g) + e^-$

Second ionisation energy and nth ionisation energy: Two or more electrons can be removed and we have successive ionization energies.

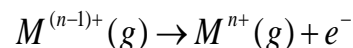
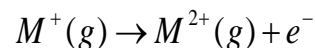

The ionization energy is usually expressed in **kiloJoules per mole (kJ.mol⁻¹)**. This energy is required to overcome the attractive force between the nucleus and the electron and then remove the electron. There are as **many successive ionisation energies as there are electrons in the original atom**. In the figure 2.14, someone can make an interpretation of successive ionization energies of an atom

2.6.2. Interpretation of a graph of successive ionization energies of an atom

The graph shows that the energy to remove electron increases as more electrons are successively removed.

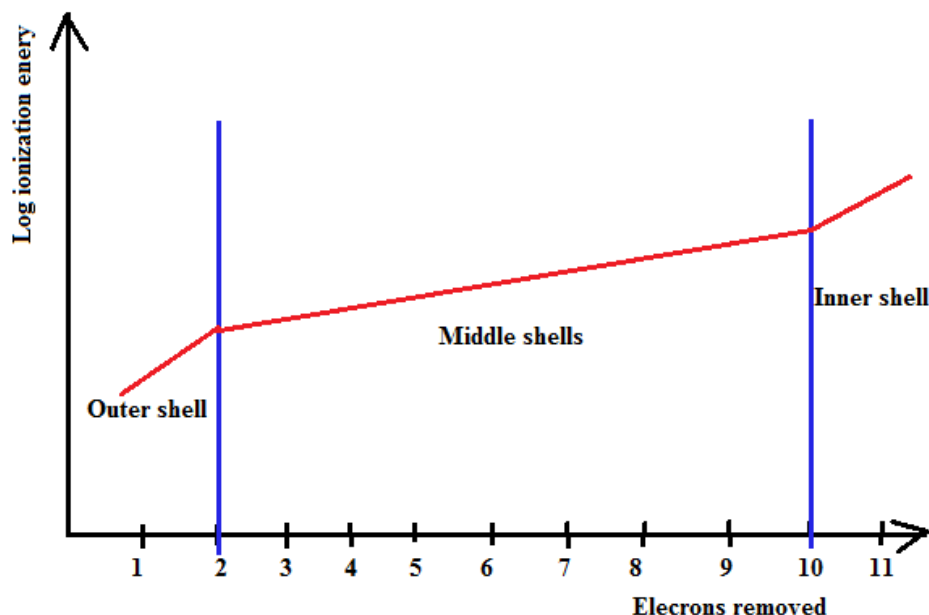

Figure 2.14: Successive I.E. for sodium

The electronic structure for sodium is $1s^2 2s^2 2p^6 3s^1$.

- a) The **energy required to remove the first electron is relatively low**. This corresponds to the loss of one 3s electron.
- b) To **remove the second electron needs a much greater energy** because this electron is closer to the nucleus in a 2p orbital. There is a steady increase in energy required as electrons are removed from 2p and then 2s-orbitals.
- c) The **removal of the tenth and eleventh electrons requires much greater** amounts of energy, because these electrons are closer to the nucleus in the 1s orbital.

2.6.3. Factors influencing the extent of ionization energy

The ionization energy as a physical property of elements that can be influenced by some factors:

1) Size of atom

The atomic size is the distance between the nucleus and valence shell. As the number of energy levels (shells) increases, the force of attraction between nucleus and valence electron decreases. Therefore, the valence electrons are loosely held to the nucleus and the lower energy is required to remove them, i.e. ionization energy decreases with increase in atomic size vice versa. This is what happens when you go down a Group.

2) Nuclear charge

The nuclear charge is the total charge of all the protons in the nucleus. As the nuclear charge increases, the force of attraction between nucleus and valence electrons increases and hence makes it difficult to remove an electron from the valence shell. The stronger the nuclear charge, the higher the ionization energy. This is what happens when you cross a period from left to right.

3) Screening effect or Shielding effect

The Screening effect or Shielding effect is due to the presence of inner electrons which have a screening or shielding effect against the attraction of the nucleus towards the outermost electrons. The electrons present in inner shells between the nucleus and the valence shell reduce the attraction between nucleus and the outermost electrons. This shielding effect increases with the increasing number of inner electrons. The stronger the Shielding effect makes it easier to remove an external electron and hence lowers the ionisation energy.

2.6.4. Importance of ionization energy in the determination of the chemistry of an element

Ionization energy provides a basis to understand the chemistry of an element. The following information is provided.

i) Atomic number

The number of successive ionization energies indicates the number of electrons present in an atom. Sodium has 11 successive ionization energies indicating that the atomic number of sodium is 11.

ii) Determination of metallic or non-metallic character.

The magnitude of I.E. is used as a measure of the metallic character of an element. The first ionization energies of metals are all nearly below 800 kJ mol^{-1} while those of non-metals are all nearly above 800 kJ mol^{-1} .

Down the group ionization energies decrease so that the elements become more metallic. In groups (IV), (V) there is change from non-metallic to metallic character. Across a period 1^{st} I.E. increases in moving across a period. The elements become less metallic but non-metallic.

iii) The use of I.E. to predict the properties of elements

Example: The first three ionization energies for elements A, B, C, and D are given in the table below

Element	Ionization energies		
	First	Second	Third
A	780	1500	7730
B	500	4560	6900
C	580	1815	4620
D	1310	3460	5300

- From the 1^{st} I.E. of the elements it can be deduced that elements B and C have typical metallic properties since their 1^{st} ionization energies are well below 800 kJ mol^{-1} .
- Element A with 1^{st} I.E. near 800 kJ also would show some metallic properties.
- Moving from 2^{nd} to 3^{rd} I.E. for A there is an increase of about 5 times. This means the 3^{rd} electron of A comes from a different shell hence A has 2 electrons on its outermost shell. A is therefore a group 2 element with charge of +2
 - For element B, there is an increase of about 9 times from 1^{st} to 2^{nd} and an increase of about

$1\frac{1}{2}$ times from 2^{nd} to 3^{rd} . Therefore element B has one electron on its outermost shell and thus is a group 1 element and would have a charge of +1.

iii) In element C, from 1^{st} to 2^{nd} i.e. increase is about 3 times and from 2^{nd} to 3^{rd} by about $2\frac{1}{2}$ times.

Therefore there is similar rise in ionization energy. This implies that the 3 electrons in C are from the same shell and C therefore would form three positive charges and hence belongs to group 3.

d) Element D with its 1^{st} I.E. well over 800kJmol^{-1} is a non metal. The following compounds therefore would be formed between.

- A and D = A_xD_2
- B and D = B_xD
- C and D = C_xD_3

Checking up 2.6

Given the 4 elements: Na, Cs, Ca and F. Given the following IEs: 375kJ/mol , 589.8kJ/mol , 375kJ/mol , 496kJ/mol . Match the different elements with the different IEs and justify why.

2.7. End unit assessment

1. Which of the following is the correct representation of for the ground-state electron configuration of molybdenum? Explain what is wrong with each of the others.

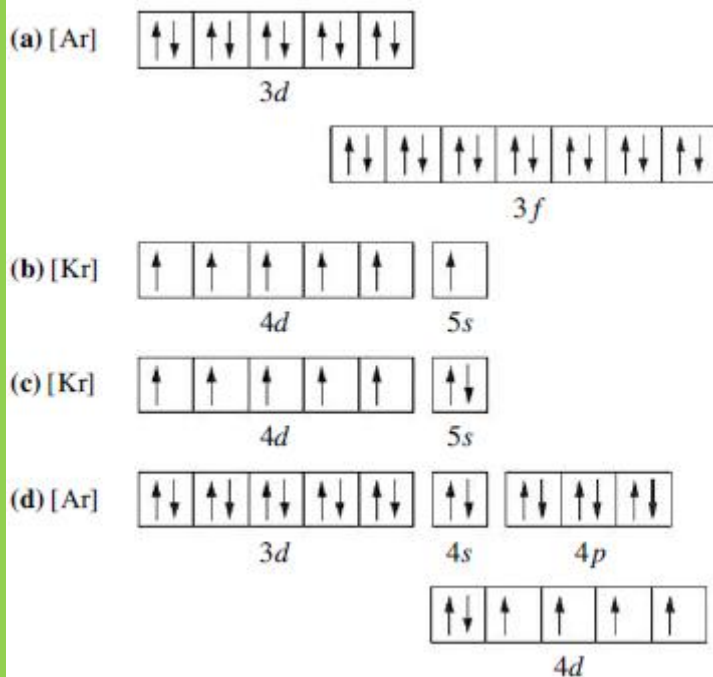

2. Which of the following electron configurations corresponds to the ground state and which correspond to an excited state?

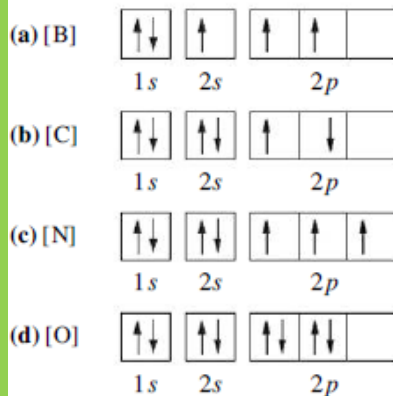

3. Photosynthesis uses 660 nm light to convert CO_2 and H_2O into glucose and O_2 . Calculate the frequency of this light.
4. Which of the following orbital designations are incorrect: 1s, 1p, 7d, 9s, 3f, 4f, 2d?
5. The data encoded on CDs, DVDs, and Blu-ray discs is read by lasers. What is the wavelength in nanometers and the energy in joules of the following lasers?
 - CD laser, $\nu = 3.85 \times 10^{14} \text{ Hz}$
 - DVD laser, $\nu = 4.62 \times 10^{14} \text{ Hz}$
 - Blu-ray laser, $\nu = 7.41 \times 10^{14} \text{ Hz}$
6. Concerning the concept of energy levels and orbitals,
 - (a) How many orbitals are found in $n = 3$ level?
 - (b) What are the names of the orbitals in $n = 3$ level?
 - (c) How many orbitals have the values $n = 4$ and $l = 3$?
 - (d) How many orbitals have the values $n = 3, l = 2$ and $m_l = -2$?
 - (e) What is the total number of orbitals in the level $n = 4$?
7. A hypothetical electromagnetic wave is pictured here. What is the wavelength of this radiation?

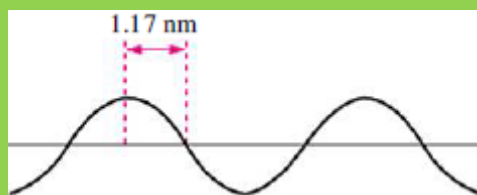

8. Consider the following waves representing electromagnetic radiation:

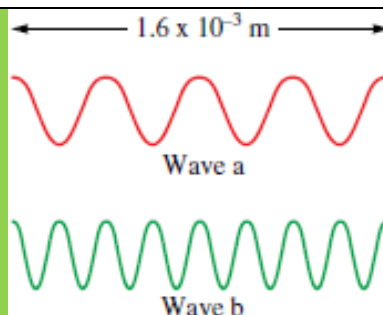

- a. Which wave has the longer wavelength?
 - b. Calculate the wavelengths of the two radiations
 - c. Which wave has the higher frequency and larger photon energy?
 - d. Calculate these values. Which wave has the faster velocity?
9. Order the orbitals for a multielectron atom in each of the following lists according to increasing energy:
- a) $5p, 5d$
 - b) $4s, 3p$
 - c) $6s, 4d$
10. According to the Aufbau principle, which orbital is filled immediately *after* each of the following in a multielectron atom?
- a) $4s$
 - b) $3d$
 - c) $5f$
 - d) $5p$
11. According to the Aufbau principle, which orbital is filled immediately *before* each of the following?
- a) $3p$
 - b) $4p$
 - c) $4f$
 - d) $5d$
12. Four possible electron configurations for a nitrogen atom are shown below, but only one represents the correct configuration for a nitrogen atom in its ground state. Which one is the correct electron configuration? Which configurations violate the Pauli Exclusion Principle? Which configurations violate Hund's rule?

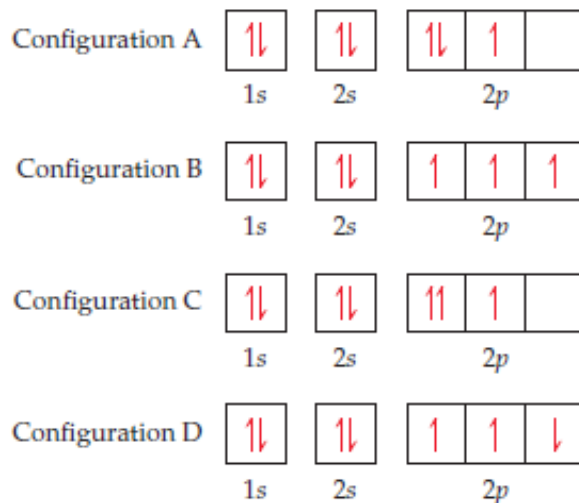

13. Explain the variation in the ionization energies of carbon, as displayed in this graph.

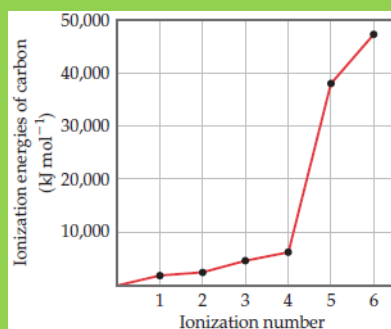

14. The first seven ionization energies of an element W are shown below

1 st I.E	2 nd I.E	3 rd I.E	4 th I.E	5 th I.E	6 th I.E	7 th I.E
785	1581	3231	4361	16002	20001	23602

- Explain what is meant by the term first ionization energy
- What factors determine the magnitude of the first ionization energy

UNIT 3: FORMATION OF IONIC AND METALLIC BONDS

Key unit competence

Describe how properties of ionic compounds and metals are related to the nature of their bonding

Learning objectives

By the end of this unit, I will be able to:

- Explain why atoms bond together;
- Explain the mechanisms by which atoms of different elements attain stability;
- Explain the formation of ionic bonds using different examples;
- Represent ionic bonding by dot-and-cross diagrams;
- Describe the properties of ionic compounds based on observations;
- Perform experiments to show properties of ionic compounds;
- Assemble experimental set up appropriately and carefully;
- State the factors that influence the magnitude of lattice energy ;
- Relate the lattice structure of metals to their physical properties;
- Describe the formation of metallic bonds;
- State the physical properties of metals and forces of attraction that hold atoms of metal.

Introduction Activity

1. Look at the pictures below and answer the following questions. Record your answers.

(a) Observe carefully pictures A, B and C and suggest the similarity between them.

(b) What can you say about the chloride and sodium ions in the pictures above?

(c) What holds the chloride and sodium ions together?

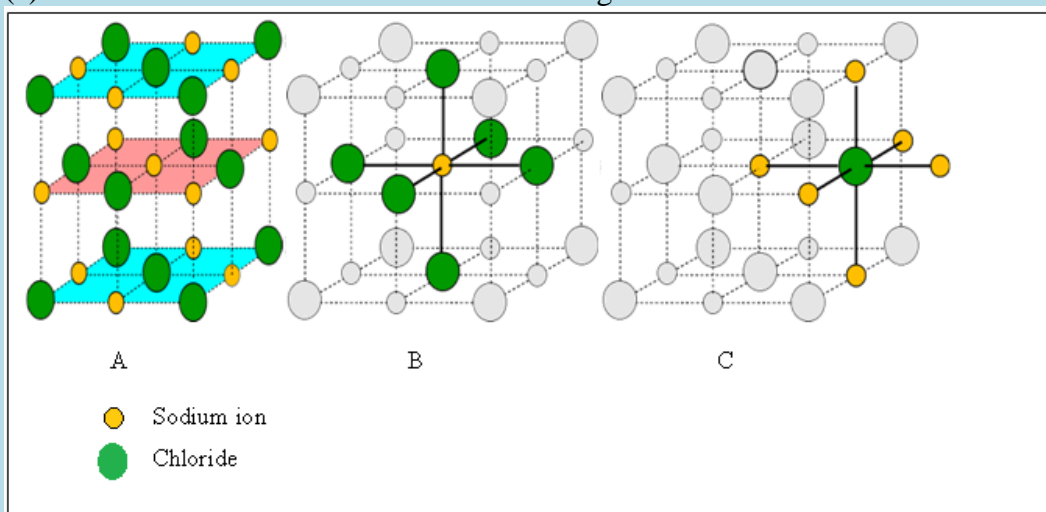

2. In S2 Chemistry you could have met chemical bonding,

(a) What is a chemical bond and why do atoms bond?

(b) In terms of bonding between atoms, suggest a reason why are materials in nature different?

People like to bond with each other for many reasons such as: to unite their forces and be stronger, to exchange ideas and produce big things, to found a family, etc. We cannot live in isolation. People can have strong connections. Similarly, some atoms can also have strong bonds between them. Some atoms have weak connections, just like two people can have connections.

Some atoms may not need to bond with others; they are self-sufficient as some people, a small number, may be self-sufficient.

Connections between atoms are called chemical bonds. Solids are one of the three fundamental states of matter. The atoms or molecules in solids are held together by strong intermolecular bonds. There are 3 types of bonding in matter that hold the atoms together in molecules: Ionic, Covalent and Metallic bond.

The type of a bond in molecules is determined by the nature and properties of the bonding atoms. However, in this unit we will only emphasize on ionic and metallic bonding.

3.1. Stability of atoms and why they bond together

Activity 3.1

- 1) In pairs discuss and write electronic configuration of sodium , neon, argon, magnesium ,aluminium oxygen chlorine
- 2) What can you say about their electronic configuration?
- 3) What happens when oxygen and chlorine gain electrons?
- 4) What happens when sodium, magnesium and aluminium lose electrons?
- 5) Discuss on how atoms of elements can gain their stabilities by either loosing or gaining electron(s) on the valence shells and show with evidence that an atom is stable?
- 6) How does the formation of an ionic bond between sodium and chlorine reflect the octet rule?

Like people always relate and connect to others depending on their values, interests and goals so does unstable atoms. They are bonded together to achieve stability. We know that noble gases are the most stable elements in the periodic table. The noble gases are extremely uncreative.

They do not tend to form compounds or combine to themselves. What do the noble gases have in common? They have a filled outer electron energy level. When an atom loses, gains, or shares electrons through bonding to achieve a filled outer electron energy level, the resulting compound is often very stable. Neutral sodium has one valence electron. When it loses this electron to chlorine, the resulting Na^+ cation has an electron energy level that contains eight electrons.

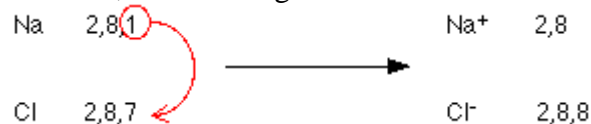

It is isoelectronic with the noble gas neon. On the other hand, chlorine has an outer electron energy level that contains seven electrons. When chlorine gains sodium's electron, it becomes an anion that is isoelectronic with the noble gas argon.

Below are examples of how magnesium bonds with oxygen and calcium with chlorine:

Example 1

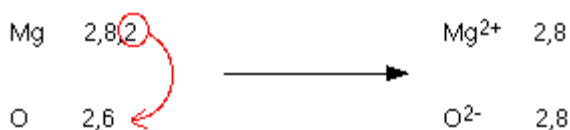

Example 2

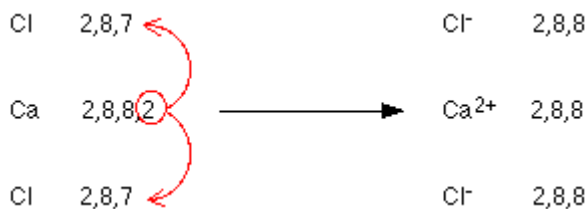

Checking Up 3.1

1. Write the shorthand electronic configuration for calcium.
2. Predict the ions that will be formed from atoms in the table, name the isoelectronic noble gas and establish the electronic configuration (E.C) of the ion formed.

Atom	Atomic number	Ion symbol	Noble gas	No. of electrons. (e ⁻)	shorthand E.C of ion formed
Br	35				
Mg	12				
S	16				
Al	13				

3.2. Ionic bonding

In an ionic bond, electrons are transferred from one atom to another so that they form oppositely charged ions in other words, one atom loses electron(s), the other gains electrons(s). The resulting strong force of attraction between the oppositely charged ions is what holds them together. Ionic bonding is the electrostatic attraction between positive and negative ions in an ionic crystal lattice.

3.2.1. Formation of ionic bond

Activity 3.2

Draw diagrams to illustrate the formation of ionic compounds in magnesium oxide, magnesium chloride, sodium peroxide, and sodium sulphide.

The transfer of electrons from one atom to another is called ionic bonding. This type of bonding occurs between metals and non-metals combine. The compounds formed are called ionic compounds. As stated previously, *metals try to lose their outer electrons while non metals look to gain electrons to obtain a full outer shell.* When metals lose their outer electrons they form positively charged ions called cations. When non-metals gain electrons they form negatively charged ions called anions. An example is shown below:

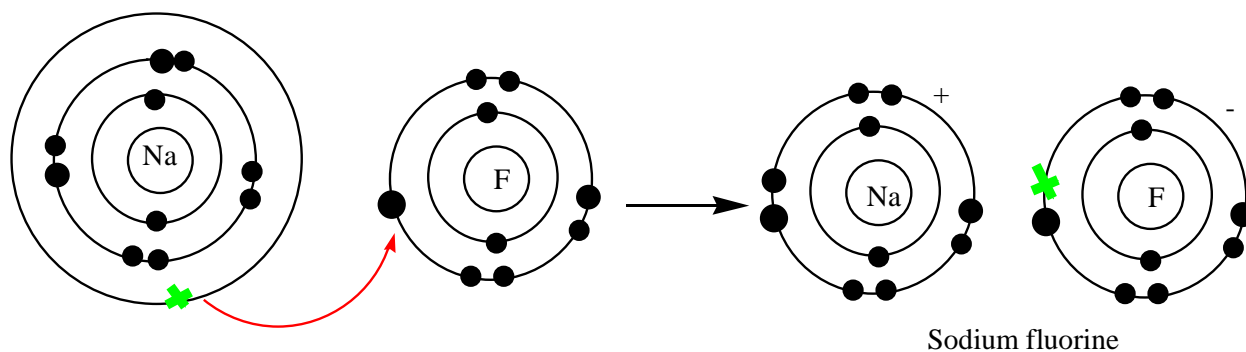

Figure 3.1: Formation of NaF

The arrow between sodium and fluorine represents the transfer of an electron from a sodium atom to a fluorine atom to form opposite ions. These 2 ions are strongly attracted to each other because of their opposite charges. A bond is now formed and the resulting compound is called Sodium Fluoride

Another example of ionic bonding is the bonding of Beryllium and Fluorine to form beryllium fluoride.

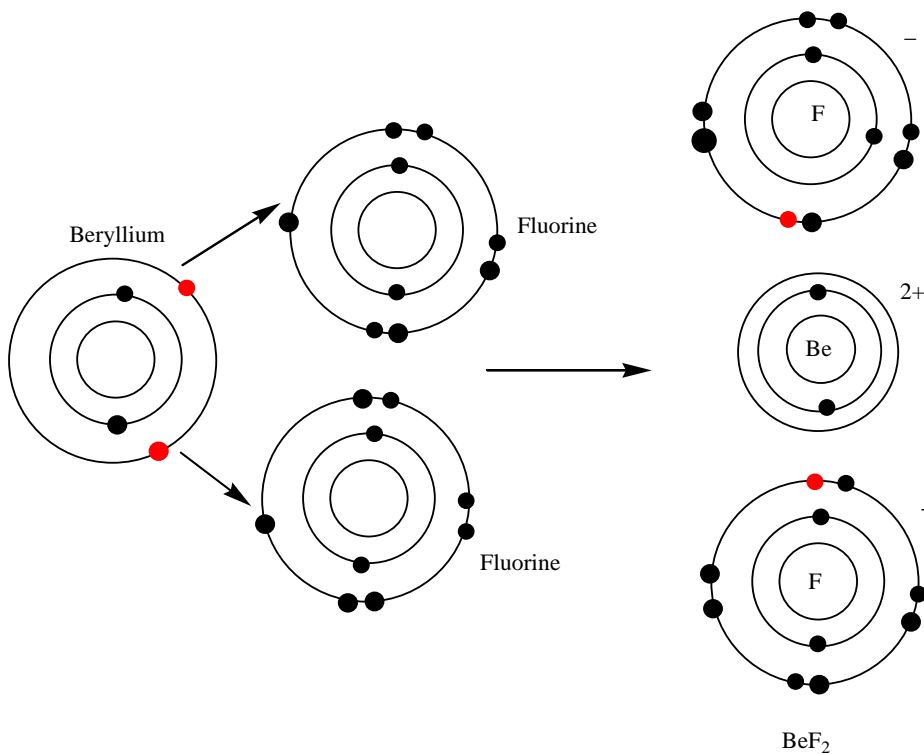

Figure 3.2: Formation of BeF₂

The transfer of electrons from beryllium results in the formation of an ionic bond. Beryllium now has a positive (+2) charge and Fluorine now has a negative charge. The resulting compound is called Beryllium Fluoride (BeF₂).

Other examples showing the formation of ionic compounds using dot and cross diagrams.

(a) Formation of calcium chloride

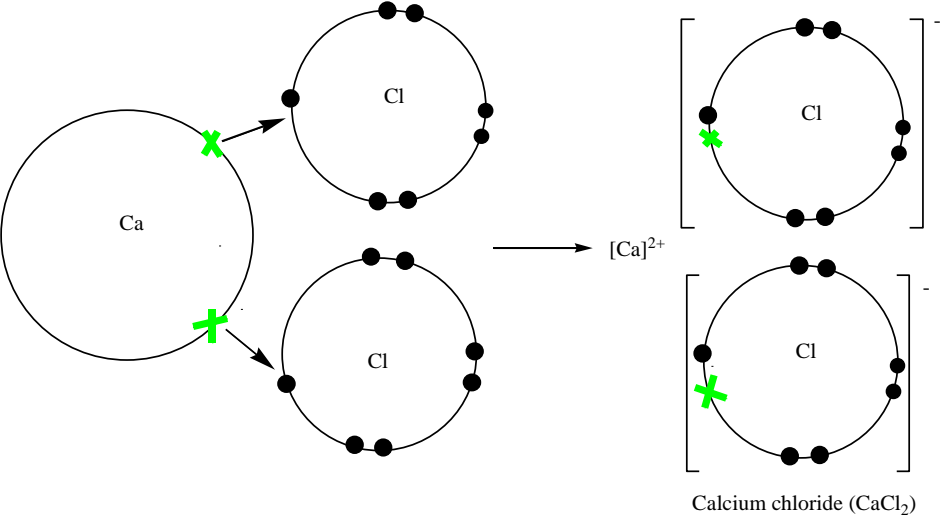

Figure 3.3: Formation of CaCl_2

(b) Formation of magnesium oxide

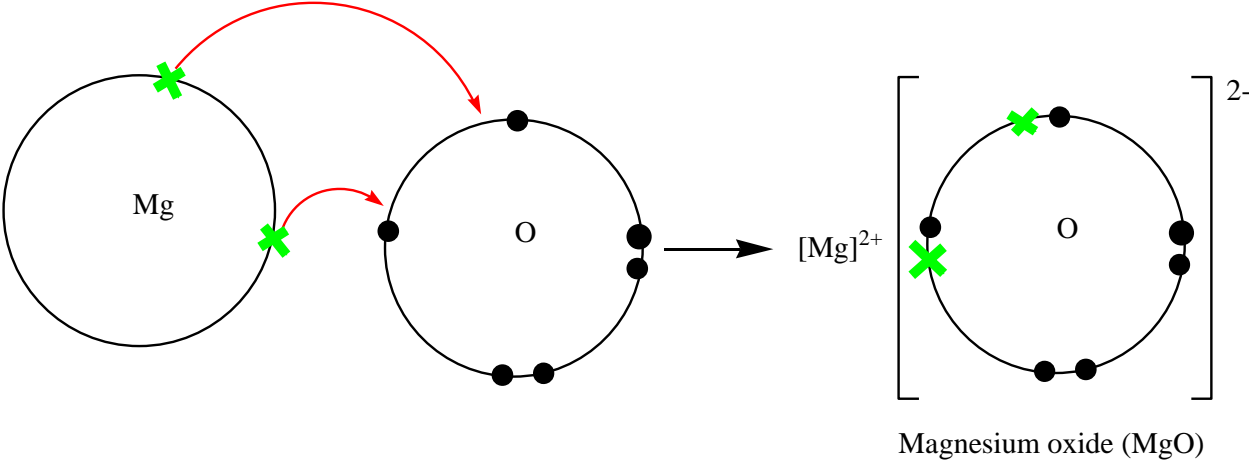

Figure 3.4: Formation of MgO

(c) Formation of bonds in sodium fluoride

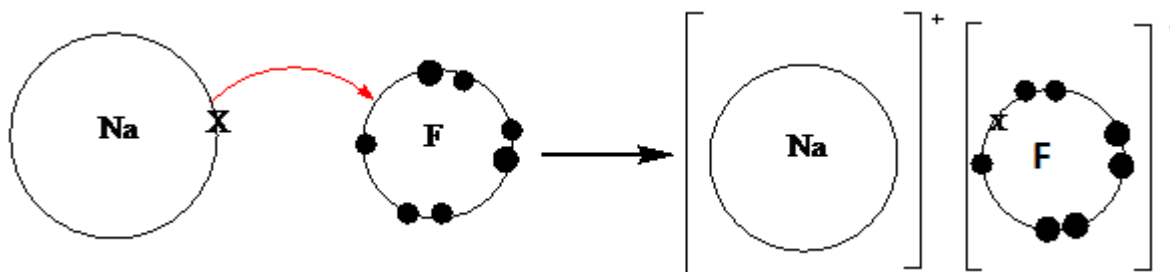

Figure 3.5: Formation of NaF

Checking Up 3.2

- For each of the following ionic bonds: Sodium + Chlorine, Magnesium + Iodine, Sodium + Oxygen, Calcium + Chlorine and Aluminium + Chlorine
 - Write the symbols for each element.
 - Draw a Lewis Dot structure for the valence shell of each element.
 - Draw an arrow (or more if needed) to show the transfer of electrons to the new element.
 - Write the resulting chemical formula.
 - Write the electron configurations for each ion that is formed. Ex. $\text{H}^{1+} = 1s^0$
- Solid sodium chloride and solid magnesium oxide are both held together by ionic (electrovalent) bonds.
 - Using s,p and d notation write down the symbol for and the electronic configuration of (i) a sodium ion; (ii) a chloride ion; (iii) a magnesium ion; (iv) an oxide ion.
 - Explain what holds sodium and chloride ions together in the solid crystal
 - Sodium chloride melts at 1074 K; magnesium oxide melts at 3125 K. Both have identical structures. Why is there such a difference in their melting points?

3.2.2. Physical properties of ionic compounds

Activity 3.3(a)

Determination of Relative Melting Point

Procedure:

1. Cut a square of aluminum foil that is about 5 by 5 cm
2. Set up a ring stand with an iron ring attached.
3. Place the aluminum square on the iron ring, as shown at right in **Figure 3.6**
4. Obtain a small pea-sized sample of NaCl. Place the sample on the aluminum foil, about 5cm from the center of the square.
5. Obtain a small pea-sized sample of table sugar. Place the sample on the aluminum foil, about 1 cm from the center of the square, but in the opposite direction from the salt.
6. Your square of aluminum foil should look like in **Figure 3.7**.
7. Light the Bunsen burner and adjust the flame height so that the tip of the flame is just a cm or so below the height of the aluminum foil.
8. Observe as the two compounds heat up.
9. Set up another sheet of aluminum foil and determine the relative melting points (low vs. high) of the four unknowns.
10. Record your results in the table 3.1 below

Caution: if the compounds burn with sparks do not panic.

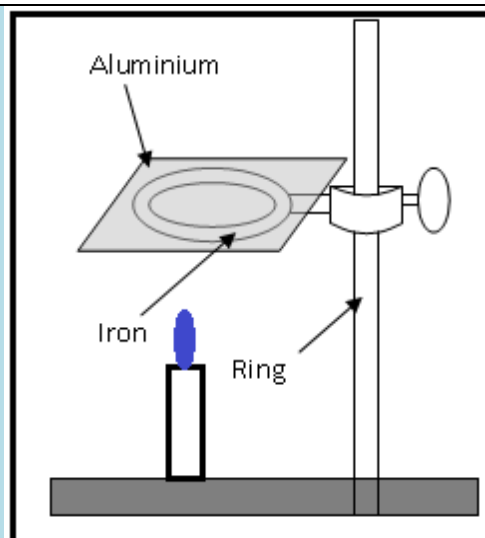

Figure 3.6: Aluminium square on the iron ring

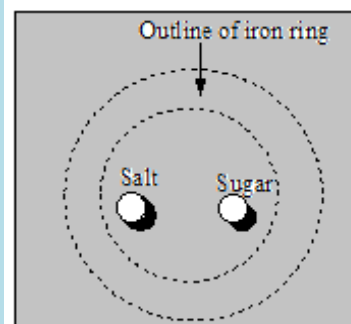

Figure 3.7: Square of aluminum foil after heating

Study question:

1. Which compound melts first?
2. Giving reasons compare the melting points of the two compounds.

Table: 3.1 relative melting points of different substances

Substance	Relative Melting Point	
	High	Low
sodium chloride crystals		
Sugar crystals		

Copper(ii)sulfate crystals			
Ice			

Conclusions:

The melting points of ionic compounds are higher than those of covalent compounds.

Activity 3.3(b)

Conductivity in Solution

Procedure:

1. Dissolve a spoonful of NaCl in water.
2. Connect the apparatus as shown in figure 3.8
3. Make an observation and record your results as in table 3.2 below
4. Repeat the procedure 1 to 3 above using sugar solution, ethanol and copper(II) sulfate solution
5. Record your results in the table below.

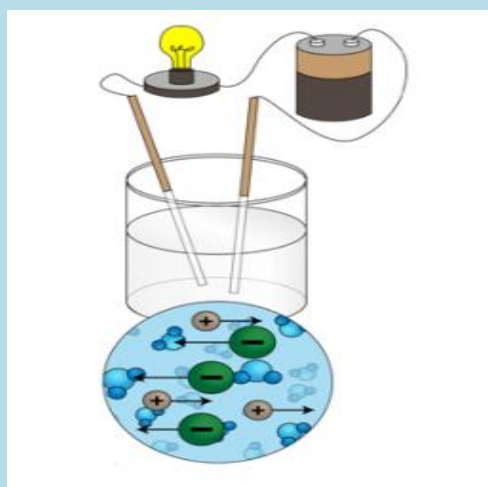

Figure:

3.8: Conductivity of solution

Table 3.2: relative conductivity of different substances

Substance	Conducts Electricity	
	Yes	No
Sodium chloride solution		
Sugar solution		
Ethanol		
Copper (II) sulphate		
Solid sodium chloride		

Study questions:

1. Give reasons for your observations above.
2. Solid sodium chloride does not conduct electricity whereas an aqueous solution of sodium chloride does. Explain

Conclusion:

Based on our tests with salt and sugar, the ability to conduct electricity in solution of ionic is more pronounced than in covalent compounds.

Activity 3.3(c) Solubility test

Procedure:

1. Using forceps, place 5-8 crystals of each of sodium chloride, magnesium chloride, copper sulphate, calcium carbonate, copper carbonate, sodium sulphate (a small pinch) of the compound into one of the test tubes in test tube rack.
2. Half-fill the test tube with distilled water and stir with a clean stirring rod.
3. Observe if the crystals dissolve in water.
4. Record your findings in a suitable table.

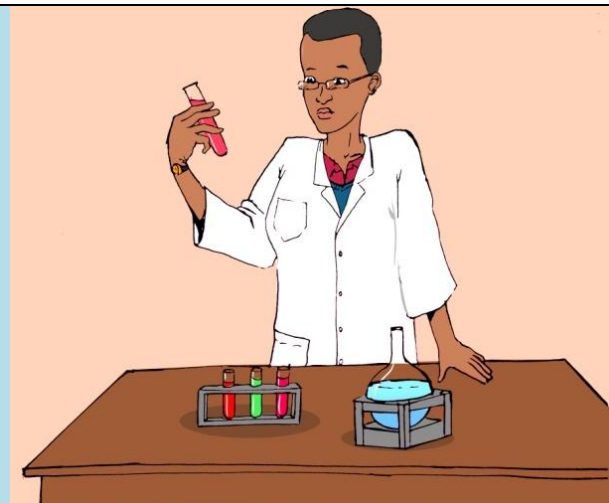

Figure 3.9: dissolution of substances

Table 3.3: Solubility of different substances

Substance	Solubility in water	
	Yes	No
Sodium chloride		
Magnesium sulphate		
Calcium carbonate		
Copper carbonate		
Sodium sulphate		

Study questions:

1. Classify substances as soluble and slightly soluble in water.
2. Giving reasons, suggest an explanation for your observation.

Conclusion:

Substances which dissolve in water are said to be ionic while those slightly soluble are covalent in nature. However, there are certain covalent compounds which dissolve in water such as sugar.

Shattering: Why are Ionic compounds generally hard, but brittle?

It takes a large amount of mechanical force, such as striking a crystal with a hammer, to force one layer of ions to shift relative to its neighbour. However, when that happens, it brings ions of

the same charge next to each other (**Figure 3.10**). The repulsive forces between like-charged ions cause the crystal to shatter. When an ionic crystal breaks, it tends to do so along smooth planes because of the regular arrangement of the ions.

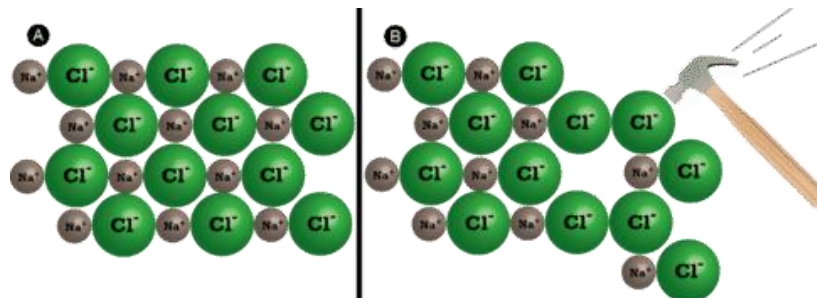
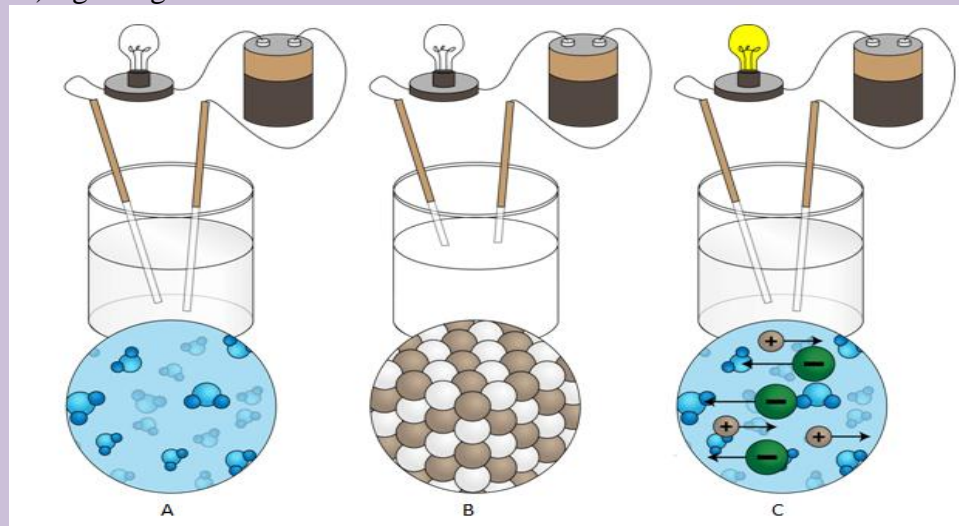

Figure 3.10: Ionic compounds are brittle

Checking Up 3.3

1. The diagrams below show the electric conductivity of distilled water, solid sodium chloride and a solution of sodium chloride respectively. Use the diagrams to explain the observations from the set up.

- i) no light is given out by bulb in A
- ii) no light is given out by bulb in B
- iii) light is given out in C



1. Why are ionic compounds brittle?
2. Why do ionic compounds have high melting points?
3. What happens when an electric current is passed through a solution of an ionic compound?

3.2.3. Lattice energy

Activity 3.4: By using information in this student's chemistry book and other books from the school library, attempt to answer the following questions.

- 1) Define lattice energy
- 2) Explain how the lattice energy is used to describe high melting points of ionic compounds.
- 3) What is the bonding force present in ionic compounds?
- 4) Why is the melting temperature of magnesium oxide higher than that of magnesium chloride, even though both are almost 100% ionic?
- 5) How is lattice energy of ionic compounds related to their high melting points?

It is a type of potential energy that may be defined in two ways. In one definition, the lattice energy is the energy required to break apart an ionic solid and convert its component atoms into gaseous ions (Endothermic process). On the other hand lattice energy is the energy released when gaseous ions bind to form an ionic solid (Exothermic process). Its values are usually expressed with the units' kJ/mol.

Lattice Energy is used to explain the stability of ionic solids. Some might expect such an ordered structure to be less stable because the entropy of the system would be low. However, the crystalline structure allows each ion to interact with multiple oppositely charge ions, which causes a highly favourable change in the enthalpy of the system. A lot of energy is released as the oppositely charged ions interact. It is this that causes ionic solids to have such high melting and boiling points. Some require such high temperatures that they decompose before they can reach a melting and/or boiling point.

Factors affecting lattice enthalpy

Activity 3.5

- 1) Basing on the information obtained from the definition of lattice energy , suggest the factors that affect the lattice energy.
- 2) Which has the larger lattice energy: NaCl or CsI?

There are two main factors that affect lattice enthalpy (these factors are influenced by distance between oppositely charged ions).

a) The charges on the ions

Sodium chloride and magnesium oxide have exactly the same arrangements of ions in the crystal lattice, but the lattice enthalpies are very different.

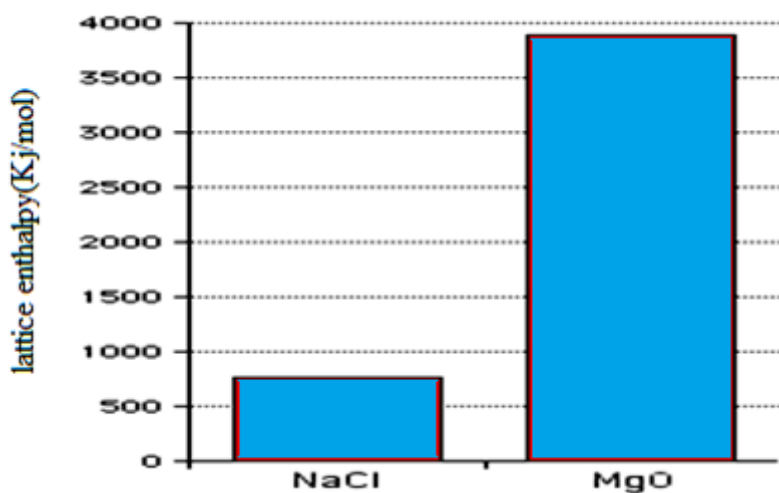

Figure 3.11: Lattice enthalpies of sodium chloride and magnesium oxide

From the above diagram the lattice enthalpy of magnesium oxide is much greater than that of sodium chloride. This is because in magnesium oxide, +2 ions are attracting -2 ions; in sodium chloride, the attraction is only between +1 and -1 ions.

b) The radius of the ions

The lattice enthalpy of magnesium oxide is also increased relative to sodium chloride because magnesium ions are smaller than sodium ions, and oxide ions are smaller than chloride ions.

That means that the ions are closer together in the lattice, and that increases the strength of the attractions.

For example, as you go down Group VII of the Periodic Table from fluorine to iodine, you would expect the lattice enthalpies of their sodium salts to fall as the negative ions get bigger - and that is the case:

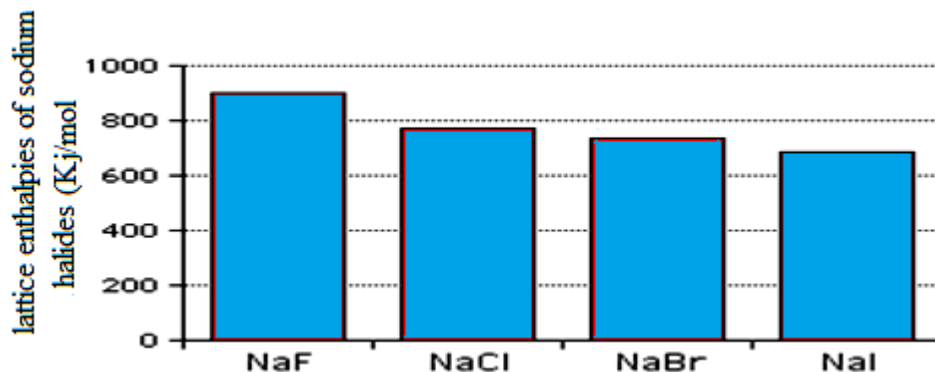

Figure 3.12: Lattice enthalpies of sodium halides

As the negative ion gets bigger in size, the distance between the centres of oppositely charged ions increase and attractions so decrease. For instance as you go down group 1 halides, the enthalpy decreases.

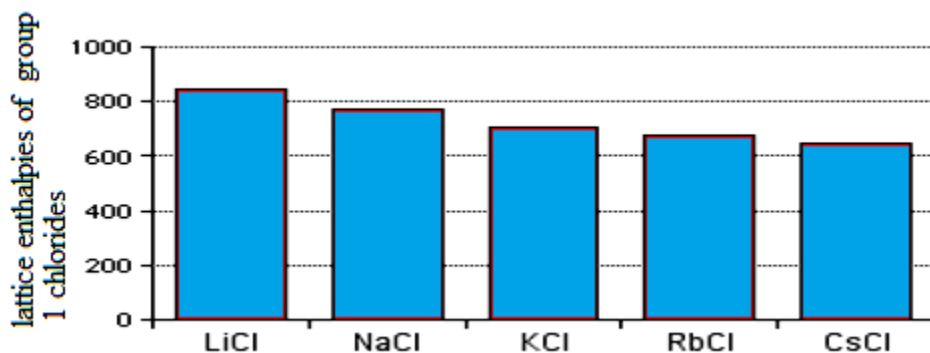

Figure 3.13: Lattice enthalpies of group 1 chlorides

Checking Up 3.4

1. Define lattice energy
2. Which one of the following has the greatest lattice energy?
 - a) MgO or NaCl
 - b) LiCl or MgCl₂
3. Which one of the following has the greatest Lattice Energy?
 - a) NaCl or CaCl₂
 - b) AlCl₃ or KCl
4. How do the ionic radius and ion charge affect the lattice energy of an ionic substance?

3.3. Formation of metallic bonds and physical properties of metals

Activity 3.6



Figure 3.14: Materials commonly used at home

The figure 3.14 shows materials commonly used at home. If you reflect back around your house/home you will see hundreds of objects made from different kinds of materials.

- 1) Observe the objects (in picture) and classify them according to the materials they are made of.
- 2) Have you ever wondered why the manufacturers choose the material they did for each item?
- 3) Why are frying saucepans made of metals and dishes, cups and plates often made of glass and ceramic?
- 4) Could dishes be made of metal? And saucepans made of ceramic and glass

3.3.1. Formation of metallic bond

Metals have a sea of delocalized electrons within its structure. These electrons have become detached and the remaining atoms have a positive charge. This positive charged is attracted to the delocalized sea of electrons due to electrostatic forces of attraction (forces which result from unlike charges), and as a result has a strong interaction. It is this interaction which makes the metals so hard and rigid. The diagram below shows the metallic bonding.

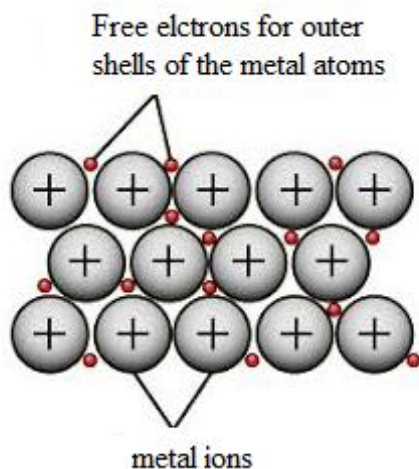

Figure 3.15 : Valence electrons shared between all metallic cations

3.3.2. Physical properties of metals

Activity 3.7: Looking at metals

1. Collect a number of metal items from your home or school. Some examples are listed below: hammer, electrical wiring, cooking pots, jewellery, burglar bars and coins, nails,
2. What is the function of each of these objects?
3. Discuss why you think metal was used to make each object. You should consider the properties of metals when you answering this question.

a) Thermal conductivity

Activity 3.8: Experiment to demonstrate the ability of different substances to conduct heat

Apparatus/apparatus: two cups (made from the same material e.g. plastic); a metal spoon and a plastic spoon.



Procedure:

- 1) Pour boiling water into the two cups so that they are about half full.

- 2) At the same time, place a metal spoon into one cup and a plastic spoon in the other.
- 3) Note which spoon heats up more quickly.
- 4) Record your observations.

Study questions:

1. Which one heats faster plastic spoon or metallic spoon and why?
2. Why do we use plastic cups?
3. Why are cooking pots made of metallic materials not plastics?

Results: The metal spoon heats up more quickly than the plastic spoon. In other words, the metal conducts heat well, but the plastic does not.

Conclusion: Metals are good thermal conductors, while plastic is a poor thermal conductor. This explains why cooking pots are metal, but their handles are often plastic or wooden. The pot itself must be metal so that heat from the cooking surface can heat up the pot to cook the food inside it, but the handle is made from a poor thermal conductor so that the heat does not burn the hand of the person who is cooking.

b) Malleability and ductility

Activity 3.9: Experiments to demonstrate the malleability and ductility of metals

Materials: wires, nails, hammer, piece of cloth.

Procedure:

1. Wrap the material to be test in a heavy plastic or cloth to avoid pieces flying from the material.
2. Place the material on a flat hard surface
3. Use a harmer to pound the material flat
4. Record your observations as malleable or non-malleable.

Metals can have their shapes changed relatively easily in two different ways i.e.

Malleable: can be hammered into sheets or

Ductile: can be drawn into rods and wires

As the metal is beaten into another shape the delocalised electron cloud continues to bind the “ions” together.

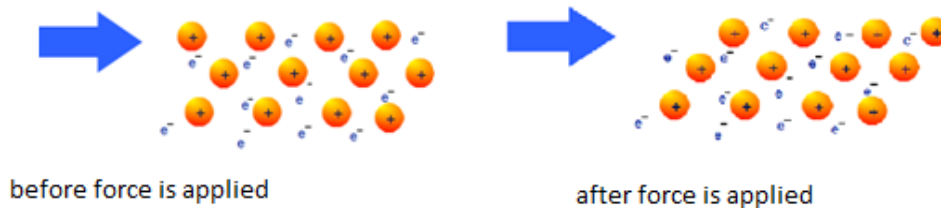

Figure 3.16: Malleability and ductility of metals

The positive ions in the lattice are all identical. So the planes of ions can slide easily over one another attractive forces in the lattice are the same whichever ions are adjacent and remain the same throughout the lattice

Some metals, such as gold, can be hammered into sheets thin enough to be translucent.

Note: If a material is pounded into a flatter shape it is called malleable but if it breaks or does not change it is called non-malleable.

c) Electrical conductivity

Activity 3.10

Procedure

1. Take a dry cell/battery, a torch bulb/ bulb, connecting wires, crocodile clips and connect them. As in the figure 3.17
2. Repeat the experiment above using different metals
3. Record your results in a suitable table.

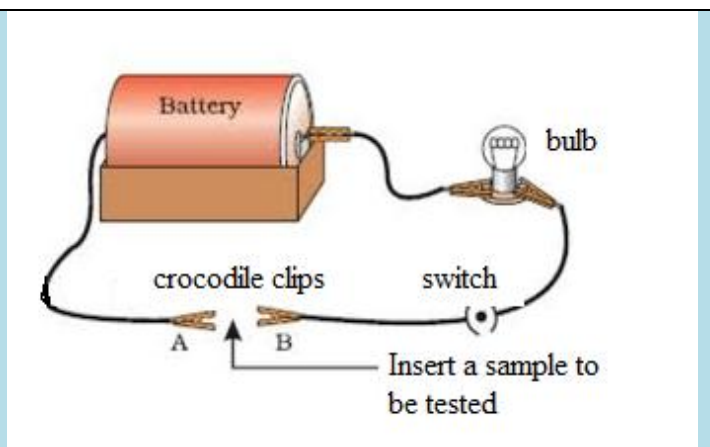

Figure 3.17: electrical conductivity of metals

Study questions:

1. Compare the relative conductivity of the metals used in the above experiment.
2. Suggest the purpose of the resistor in the experimental set up.

Conclusion:

Metals allow electricity to pass through them easily. So they are conductors of electricity. Silver and copper are the best conductors of electricity.

Note: mercury is a poor conductor of electricity.

d) Metal appear shiny/lustrous

Activity 3.11: Demonstration of shininess in metals

Procedure:

1. Hold a small piece of sodium metal using forceps.
2. Place it on a hard surface and cut it into two parts
3. Observe the cut surface. What do you observe?
4. Look at the surface of aluminium sheets, how does it appear?

Study question:

Explain what makes metal surfaces appear shiny/luster.

Light is composed of very small packages of electromagnetic energy called photons. We are able to see objects because light photons from the sun (or other light source) reflect off of the atoms within the object and some of these reflected photons reach the light sensors in our eyes and we can see the objects.

When photons of light hit the atoms within an object three things can happen:

The photons can bounce back from the atoms in the object, can pass through an object such as glass or can be stopped by the atoms within the object.

Objects that reflect many photons into our eyes make the objects appear shiny. Objects that absorb photons and reflect less photons appear dull or even dark black to our eyes.

Did you know? Of all of the metals, aluminium and silver are the shiniest to our eyes. Gold is also one of the more shiny metals. However, gold is not as shiny as silver and aluminium. Mercury, a liquid metal, is also shiny and special telescope mirrors have been made of mercury.

(e)Melting and boiling points

Activity 3.12:

1. Why do metals have variable melting points?
2. Why do metals have high melting points compared to non-metals?

Melting point is a measure of how easy it is to separate individual particles. In metals it is a measure of how strong the electron cloud holds the positive ions. The ease of separation of ions depends on the: electron density and Ionic / Atomic size.

Melting point increases across the period (**from Na---Al**), the electron cloud density increases due to the greater number of electrons donated per atom. As a result the ions are held more strongly. Hence more energy will be needed to separate the ions as shown in the table 3.4.

Table 3.4: Electron density as a factor that influence melting and boiling points of metal

Electron density/period 3	Mpt	Bpt
Na (2,8,1)	98°C	890°C
Mg (2,8,2)	650°C	1110° C
Al (2,8,3)	659°C	2470°C

Conversely, as the size of the atom/ion increases down the group the melting and boiling points decrease as shown in the table 3.5

Table 3.5: Ionic/Atomic size as a factor that influence melting and boiling points of metals

Size of atoms/ions of Group1	Mpt	Bpt
Li (2,1) (182 pm)	180.54°C	1347.0°C
Na (2,8,1) (227 pm)	98°C	890° C
K (2,8,8,1) (280 pm)	61.38°C	759°C

3.3.3. Factors affecting the strength of metallic bonds.

Activity 3.13

1. Explain different strengths of metallic bonds in different metals?
2. Compare the metallic strength of the following metals:
 - (i) Sodium and magnesium
 - (ii) Sodium and potassium

The three main factors that affect the metallic bond are:

- **Number of protons/ Strength of nuclear attraction:** (The more protons the stronger the force of attraction between the positive ions and the delocalized electrons)
- **Number of delocalized electrons per atom:** The more delocalized electrons the stronger the force of attraction between the positive ions and the delocalized electrons
- **Size of atom:** The smaller the atom, the stronger the force of attraction between the positive ions and the delocalized electrons and vice-versa, the larger the atom, the weaker the force of attraction between the positive ions and the delocalised electrons.

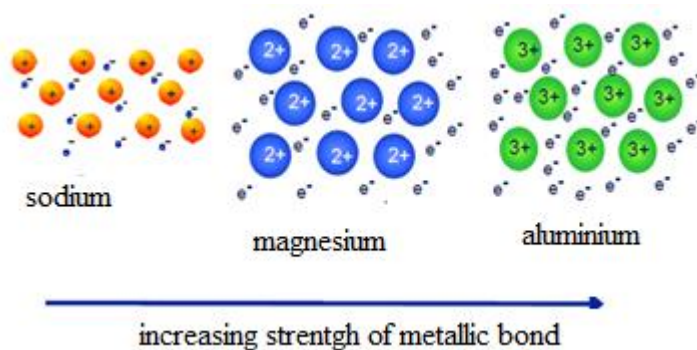

Figure 3.18: Variation of strength of metallic bond

The strength increases across a period from left to right because:

The atoms have more protons. There are more delocalized electrons per atom. Electrons are added to the same energy level. Group 1 elements have 1 electron in their outer shells and so donate 1 electron to the sea of electrons, Group 2 elements donate 2 electrons per atom, and Group 3 elements donate 3 electrons per atom

If the atoms/ions are smaller; there is therefore a greater force of attraction between the positive ions and the delocalized electrons.

In group 1 elements, the melting and boiling points decrease as the size increases hence attraction between the delocalize electrons and metal cations as shown below in the table 3.6

Table 3.6: variation of melting and boiling points of group 1 elements

Group 1 element	Melting point	Boiling point
Lithium	180	1336
Sodium	98	883

Potassium	64	759
Rubidium	39	700
caesium	29	670

Checking Up 3.6

1. Look at the table below, which shows the thermal conductivity of a number of different materials, and then answer the questions that follow:

Material	Thermal Conductivity (W/m/K)
Silver	429
Stainless steel	16
Standard glass	1.05
Concrete	0.9 - 2
Red brick	0.69
Water	0.58
Snow	0.5 - 0.25
Wood	0.04 - 0.12
Polystyrene	0.03
Air	0.024

The higher the number in the second column, the better the material is at conducting heat (i.e. it is a good thermal conductor). Remember that a material that conducts heat efficiently will also lose heat more quickly than an insulating material. Use this information to answer the following questions:

- 1) Name two materials that are good thermal conductors.
 - 2) Name two materials that are good insulators.
 - 3) Explain why:
 - a) cooler boxes are often made of polystyrene
 - b) Homes that are made from wood need less internal heating during the cold months.
 - c) Igloos (homes made from snow) are so good at maintaining warm temperatures, even in freezing conditions.
 - d) Houses covered by iron sheets and houses covered by tiles can be compared in their capacity of keeping the interior of the house hot of fresh during a sunny and hot day.
2. Magnesium has a higher melting and boiling point than sodium. This can be explained in terms of the electronic structures, the packing, and the atomic radii of the two elements.
- a) Explain why each of these three things causes the magnesium melting and boiling points to be higher.
 - b) Explain why metals are good conductors of electricity.
 - c) Explain why metals are also good conductors of heat.
3. Pure metals are usually malleable and ductile.

- a) Explain what those two words mean.
- b) If a metal is subjected to a small stress, it will return to its original shape when the stress is removed. However, when it is subjected to a larger stress, it may change shape permanently. Explain, with the help of simple diagrams why there is a different result depending on the size of the stress.
- c) When a piece of metal is worked by a blacksmith, it is heated to a high temperature in a furnace to make it easier to shape. After working it with a hammer, it needs to be re-heated because it becomes too difficult to work. Explain what is going on in terms of the structure of the metal.
- d) Why is brass harder than either of its component metals, copper and zinc?

3.4. End Unit Assessment

1. Choose from a list of words and fill in the missing words in the text below:

List of words:

Conduct electricity electrodes electrolysis electrostatic attraction free electrons, good conductivity, great malleability, high density, high melting points, ionic bond, metal, negative ion, non-metal, positive ion, regular crystal shape and attractive forces.

Text:

Metals have a layered structure of in fixed positions but between them are oppositely charged that can move around at random between the metal atoms. There is a strong between these oppositely charged particles which gives them The strong forces also give a making the average heavier than an average The presence of in the structure keeps the bonding intact when metals are bent or hammered giving them..... Also, these give metalsas regards heat and electricity.

When electrons are transferred from (usually) atom (e.g. sodium) to..... atom (e.g. chlorine) an ionic bond is formed. Sodium loses an electron to form a singly charged and chlorine gains an electron to form a singly charged **negative ion**. In an ionic compound, the ionic bond is the electrostatic **attraction** between the neighbouring positive ions and negative ions. The strong forces holding this giant ionic lattice together give these ionic compounds..... and.....

When ionic compounds are melted they are found to in a process calledusing electrical contacts called..... In this process, move to the negative electrode (cathode) and metals are released. At the same time,move to the positive electrode (anode) and are formed.

1. Research from the internet or text books to find out other physical properties of metals and ionic compounds that are not mentioned above.

Multiple choice questions:

Answer these questions by choosing the best alternative represented by letters from A, B, C and D.

1. **Metals lose electrons from their lattice to become**

- A. positive ions
- B. negative ions
- C. alkalis
- D. non- metals

2. **Neither ions nor electrons are free to move in**

- A. liquids
- B. metals
- C. ionic solids
- D. All of the above

3. **Attractive forces between metal ions and delocalized electrons can be weakened or overcome by**

- A. hammer
- B. high temperature
- C. water
- D. All of the above

4. **Metals are good conductors due to**

- A. ionic lattices
- B. crystalline lumps
- C. mostly solids
- D. delocalized electrons

5. **Most atoms adopt one of three simple strategies to achieve a filled shell. Which of the following is NOT one of these strategies?**

- A. They accept electrons
- B. They share electrons
- C. They give away electrons
- D. They keep their own electrons

6. **Which of the following is NOT a type of chemical bond?**

- A. Covalent
- B. Metallic

C. Valence

D. Ionic

7. In metallic bonding...

A. One atom takes the outer shell electrons from another atom.

B. A couple of atoms share their electrons with each other.

C. Some electrons are shared by all the atoms in the material.

D. Bonding takes place between positively charged areas of one atom with a negatively charged area of another atom.

8. Which of the following is NOT a characteristic of metals?

A. Shiny /lustre

B. Brittle/Shatters easily

C. Conducts electricity

D. Malleable

9. When two or more metal elements are combined they form an...

A. bronze

B. alloy

C. Covalent bond

D. Brass

10. Sulphur is a solid non-metallic element at room temperature, so it is?

A. A good conductor of heat

B. A substance with a low melting point

C. Easily bent into shape

D. A good conductor of electricity

11. Copper is a metallic element so it is likely to be a?

A. substance with a low boiling point

B. poor conductor of electricity

C. good conductor of heat

D. substance with a low melting point

12. Sodium chloride is a typical ionic compound formed by combining a metal with a non-metal. Sodium chloride will?

A. have a low melting point

B. consist of small NaCl molecules

C. conduct electricity when dissolved in water

D. not conduct electricity when molten

13. Copper is a metallic element so it is likely to be a?

A. Substance with a shiny surface

B. Poor conductor of electricity

C. Poor conductor of heat

D. Substance with a low melting point

14. When an ionic bond is formed between atoms of different elements?

- A. Protons are transferred
- B. Electrons are transferred
- C. Protons are shared
- D. Electrons are shared

15. Sodium chloride has a high melting point because it has?

- A. Many ions strongly attracted together
- B. Strong covalent double bonds
- C. A giant covalent 3-dimensional structure
- D. Molecules packed tightly together

16. Which substance is likely to have a giant ionic structure?

- A. Melts at 1400°C, insoluble in water, good conductor of electricity either when solid or molten
- B. Melts at 2800°C, insoluble in water, non-conductor of electricity when molten or solid
- C. Melts at 17°C, insoluble in water, non-conductor of electricity either when solid or molten
- D. Melts at 2600°C, dissolves in water, non-conductor of electricity when solid, undergoes electrolysis in aqueous solution

17. Sodium chloride conducts electricity when

- A. Solid or molten
- B. Solid or in solution
- C. Molten or in solution
- D. Non of the above

18. The structure of magnesium oxide is a

- A. Giant covalent lattice
- B. Giant ionic lattice
- C. Simple ionic lattice
- D. All the above

19. What is the formula for magnesium chloride (contains Mg^{2+} and Cl^{-} ions)?

- A. $MgCl$
- B. Mg_22Cl
- C. $MgCl_2$
- D. $MgCl_3$

20. Why does sodium chloride have a lower melting point than magnesium chloride?

- A. Its positive ions are smaller and have a smaller charge
- B. Its positive ions are larger but have a smaller charge
- C. Its positive ions are smaller but have a larger charge
- D. All the above

21. Explain the conductivity of sodium chloride

- A. It conducts electricity when molten because it contains free electrons

- B. It conducts electricity when molten because sodium has metallic bonding
- C. It conducts electricity when molten because its ions are free to move.
- D. None of the above

Short and long answer questions

22.(a) Explain why the lattice dissociation enthalpy of NaBr is a bit less than that of NaCl.

(b) Explain why the lattice dissociation enthalpy of MgO is about 5 times greater than that of NaCl

23.a) The table (using figures for lattice energies from gives experimental and theoretical values for the silver halides.(The values are listed as lattice dissociation energies.) compare the values and give a detailed explanation.

Silver halides	Calculated value	Expected value
AgF	220	228
AgCl	199	217
AgBr	105	215
AgI	186	211

(b) For AgF, the experimental and theoretical values are very close. What does that show?

UNIT 4: COVALENT BOND AND MOLECULAR STRUCTURE

Key Unit Competence

Demonstrate how the nature of the bonding is related to the properties of covalent compounds and molecular structures.

Learning objectives

By the end of this unit, I will be able to:

- Define octet rule as applied to covalent compounds.
- Explain the formation of covalent bonds and describe the properties of covalent compounds.
- Describe how the properties of covalent compounds depend on their bonding.
- Explain the rules of writing proper Lewis structures
- Draw different Lewis structures
- State the difference between Lewis structures from other structures.
- Apply octet rule to draw Lewis structures of different compounds.
- Make the structures of molecules using models.
- Write the structures of some compounds that do not obey octet rule.
- Explain the formation of dative covalent bonds in different molecules.
- Compare the formation of dative covalent to normal covalent bonding.
- Describe the concept of valence bond theory.
- Relate the shapes of molecules to the type of hybridization.
- Differentiate sigma from pi bonds in terms of orbital overlap and formation.
- Explain the VSEPR theory.
- Apply the VSEPR theory to predict the shapes of different molecules/ions.
- Predict whether the bonding between specified elements will be primarily covalent or ionic.
- Relate the structure of simple and giant molecular covalent compounds to their properties.
- Describe simple and giant covalent molecular structures.
- Describe the origin of inter-molecular forces.
- Describe the effect of inter and intra molecular forces on the physical properties of certain molecules.
- Describe the effect of hydrogen bonding in the biological molecules.
- Relate the physical properties to type of inter and intra molecular forces in molecules.
- Compare inter and intra molecular forces of attraction in different molecules.

Introductory activity

The pictures below show the chemical molecules that are used as drugs and some are found in human body.

Observe the pictures A, B, C, D, E and F carefully

1. Identify the similarity between A, B and C?
2. Identify the similarity between D and E?
3. Identify the elements that make up those compounds, D and F?
4. How are elements joined together?

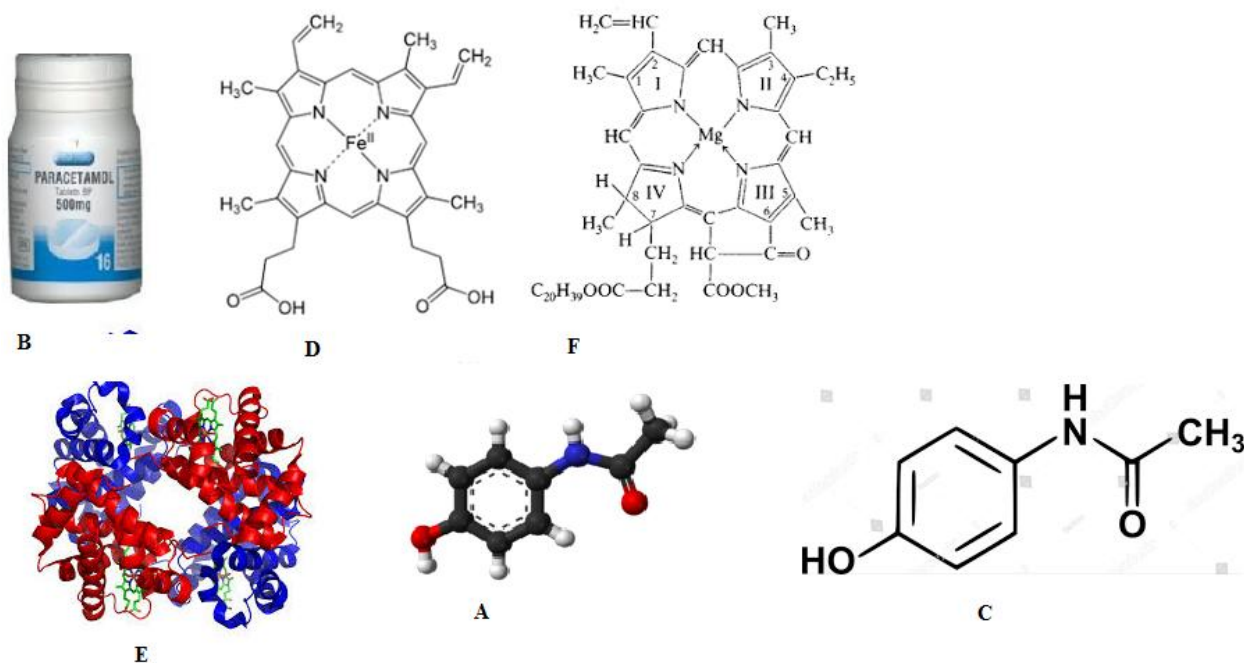

4.1. Overlap of atomic orbitals to form covalent bonds

Activity 4.1

1. Using dot and cross diagrams, show how a covalent bond is formed in:

- Hydrogen molecule (H_2)
- Hydrogen chloride molecule (HCl)
- Chlorine molecule (Cl_2).

The covalent bond is a bond formed when atoms share a pair of electrons to complete the octet. Similarly, people need each other irrespective of their race, economic, political and social status for the success of human race. Some compounds that exist in nature such as hemoglobin in our blood, chlorophyll in plants, paracetamol, responsible for transport of oxygen, green color in plants and as pain killer respectively are made of the covalent bond. The covalent bonds mostly occur between non-metals or between two of the same (or similar) elements. Two atoms with similar electronegativity do not exchange an electron from their outermost shell; the atoms instead share electrons so that their valence electron shell is filled.

In general, covalent bonding occurs when atoms share electrons (Lewis model), *concentrating electron density between nuclei*. The build-up of electron density between two nuclei occurs when a valence atomic orbital of one atom combines with that of another atom (Valence bond theory). In Valence bond theory, the bonds are considered to form from the overlap of two atomic orbitals on different atoms, each orbital containing a single electron.

The orbitals share a region of space, i.e. they overlap. The overlap of orbitals allows two electrons of opposite spin to share the common space between the nuclei, forming a covalent bond.

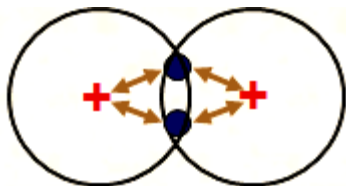

As example, we can consider the case of hydrogen molecule. The molecule of hydrogen is made of two hydrogen atoms bonded together, this is made by the two spherical 1s orbitals overlap, and contains two electrons with opposite spins (Figure 4.1)

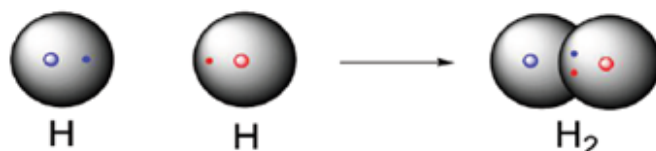

Figure 4.1: Two spherical 1s orbital of H forming hydrogen molecule

These two electrons are attracted to the positive charge of both the hydrogen nuclei, with the result that they serve as a sort of '**chemical glue**' holding the two nuclei together. The following figure (Figure 4.2) shows the distance between the two nuclei. If the two nuclei are too far apart, their respective 1s-orbitals cannot overlap and no covalent bond is formed. As they move closer each other, the orbital overlapping begins to occur, and a bond starts to form. The potential energy of the system is decreased, and the electrostatic interactions become possible between the nucleus of one atom and the electron of the second. At the same time, as the atoms get closer, the repulsive interaction (positive-positive) between the two nuclei begins to increase. It is well known that when two nuclei are too neighboring, they are unstable due to the repulsion of positive charges.

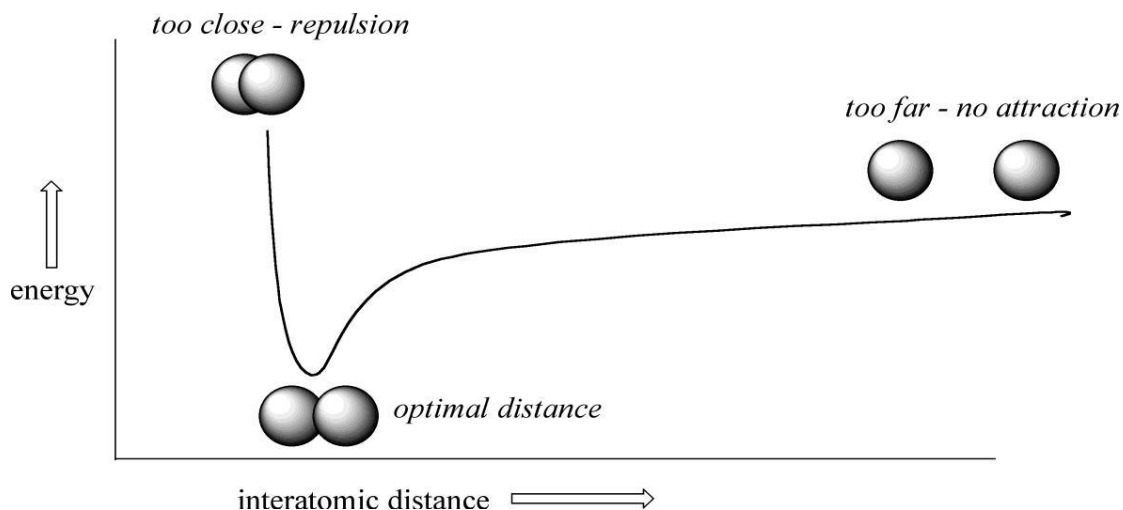

Figure 4.2: Attraction or repulsion of two nuclei

The examples below represent different atoms overlapping in order to form sigma and pi covalent bonds

Example 1: Water formation

Water molecule is formed by two atoms of hydrogen and one atom of oxygen, its formula is H_2O .

The steps of water formation are indicated in the Figure 4.3.

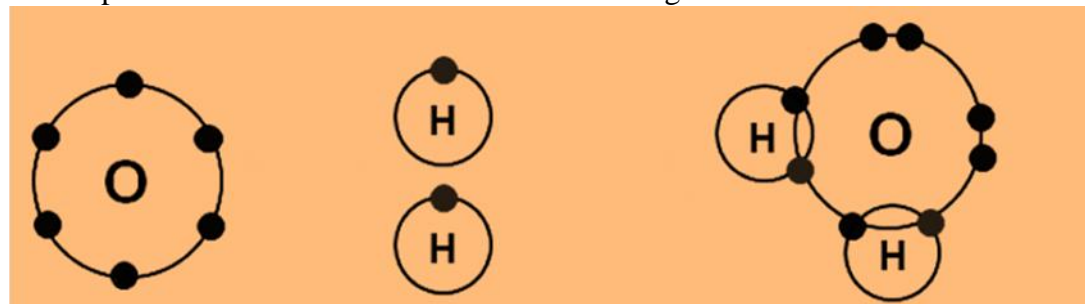

Oxygen atom

Two hydrogen atoms

Water molecule

Figure 4.3: Water formation by covalent bond

The oxygen atom has 6 electrons in the valence shell and needs two electrons to complete its outer shell. Similarly, each hydrogen atom has one electron valence and needs one electron to complete its outer shell. Therefore, oxygen can only share 2 of its 6 electron valence otherwise it will exceed the maximum of 8; the two lone pairs remain.

Example 2: Formation of hydrogen chloride (Figure 4.4)

The molecule of hydrogen chloride is made by covalent bond between one chloride atom and a one hydrogen atom as shown below.

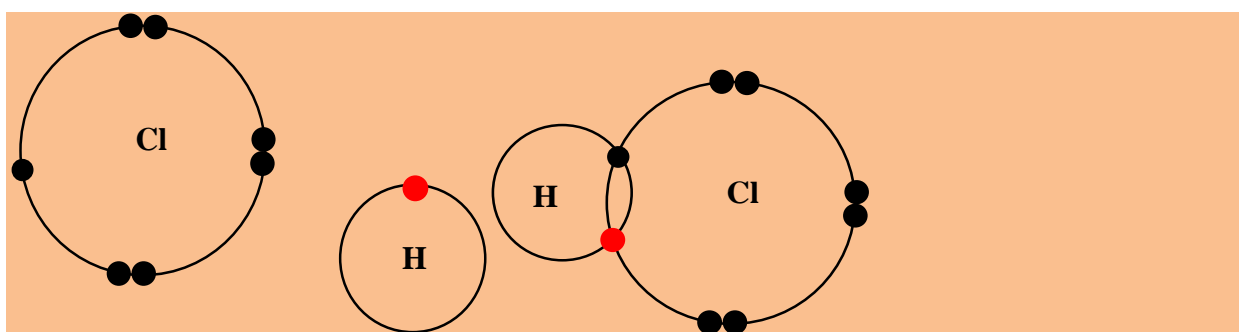

Chlorine atom

hydrogen atom

Hydrogen chloride molecule

Figure 4.4: Formation of hydrogen chloride molecule

The chlorine atom has 7 electrons in the valence shell and needs one electron to complete its outer shell. Similarly, the hydrogen atom has one electron valence and needs one electron to

complete its outer shell. The two atoms share one single electron in their outer shell to make a covalent bond in order to become stable.

Example 3: Formation of ammonia (NH_3) (Figure 4.5)

The ammonia is a compound formed by one atom of nitrogen and three atoms of hydrogen as indicated below.

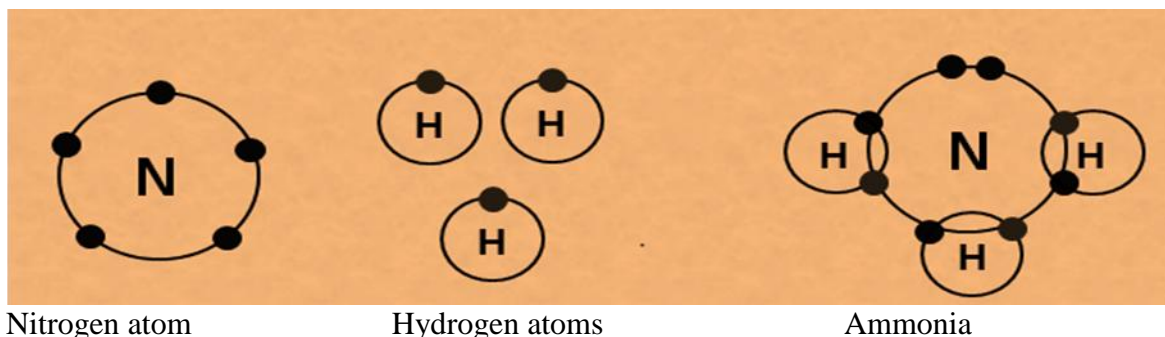

Figure 4.5: Formation of ammonia

Nitrogen atom needs three electrons to complete its outer shell and each hydrogen atom needs one electron to complete its outer shell. Then, nitrogen can only share 3 of its 5 electrons in order not to exceed the maximum of 8. A lone pair remains.

4.1.1 Properties of covalent molecules

The covalent molecules are chemical compounds in which a group of atoms are all bonded together with one another through covalent bonds. The covalent bond occurs when two atoms share two electrons. The covalent compounds possess different properties and some are emphasized below.

- Covalent compounds have low melting and boiling points: covalent compounds, contrary to ionic compounds, exist as individual molecules held together by weak attraction forces. Those weak forces between molecules can be broken easily to separate the molecules and this explains why covalent substances have relatively low melting and boiling points. Typical melting points for covalent compounds range from -200°C up to about 0°C .
- Covalent compounds do not display the electrical conductivity either in pure form or when dissolved in water. This can be explained by the fact that the covalent compounds do not have charged particles able to transport electricity. In general, the ionic compounds are good conductors of electricity compared to covalent compounds since they form positively and negatively charged ions in solution to conduct the electrical charges.

- Many of the covalent compounds do not dissolve in water. Generally, many covalent compounds are non-polar molecules and they are well dissolved in non-polar compounds rather than water which is polar. For example, oil, non-polar cannot be dissolved in water

Checking up 4.1

Using dot and cross diagram draw the diagrams to show the formation of bonds in the following molecules:

1 Ammonia (NH₃) (b) carbon dioxide gas (CO₂) (c) Nitrogen molecule (N₂) (d) tetra chloromethane (CCl₄) (e) methane (CH₄) (e) oxygen molecule (O₂)

2. Explain the properties of covalent molecules compared to ionic compounds.

4.2. Lewis structures

Activity 4.2(a)

1. Draw the diagrams indicating only the valence electrons of the following :

(i) Chlorine molecule (Cl₂) (ii) Carbon atom (C) (iii) Phosphorus atom (P)

2. Draw the diagram to show how all electrons are shared in a molecule of

(i) NH₃ indicating all unshared electrons.

(ii) HCl (iii) O₂ (IV) N₂

3. Identify the common feature possessed by the diagrams drawn above.

4. Suggest the name given by those diagrams drawn above.

The Lewis structure is a representation of covalent molecules or polyatomic ions where all valence electrons are distributed to the bonded atoms as shared electron pair (bond pairs) or unshared electron (lone pair). We then combine electrons to form covalent bonds until we come up with a Lewis structure in which all of the elements (with the exception of the hydrogen atoms) have an octet of valence electrons.

The representation of Lewis structures follows different steps:

Step 1 involves the determination of the total number of valence electrons.

Step 2 consists in writing the skeleton structure of the molecule; if there is more than one atom type in the molecule, put the most metallic or least electronegative atom in the center. Recall that electronegativity increases as we move from left to right in the periodic table.

Step 3 shows the use of two valence electrons to form each bond in the skeleton structure.

Step 4 is the fulfillment of the octets of the atoms by distributing the remaining valence electrons as nonbonding electrons.

The 4 steps are the main ways used to represent Lewis structures. If the octets are incomplete, and more electrons remain to be shared, move one electron per bond per atom to make another bond. Note that in some structures there will be empty orbitals (example: the B of BF_3), or atoms which have ten electrons (example: P in PF_5) or twelve electrons (example: S in SF_6).

The first step in this process involves the calculation of the number of valence electrons in the molecule or ion. In the case of a neutral molecule, this is nothing more than the sum of the valence electrons on each atom. If the molecule carries an electric charge, we add one electron for each negative charge or subtract an electron for each positive charge.

In Lewis structure, the least electronegative element is usually the central element, except that H is never the central element, because it forms only one bond.

Examples

1. Calculate n (the number of valence (outer) shell electrons needed by all atoms in the molecule or ion to achieve noble gas configurations for instance

For PF_3 ,

$$n = 1 \times 8 (\text{P atom}) + 3 \times 8 (\text{F atom}) = 32 \text{ electrons needed}$$

For NO_3^- , $n = 1 \times 8 (\text{for N atom}) + 3 \times 8 (\text{for O atom}) = 32 \text{ electrons}$.

Calculate A , number of electrons available in the valence (outer) shells of all the atoms. For negatively charged ions, add, to this total number a number of electrons equal to the charge of the anions. Subtract the number of electrons equal to the charge on the cation. For instance

NO_3^- ,

$$A = 1 \times 5 (\text{for N}) + 3 \times 6 (\text{for O atom}) + 1 (\text{for } -1 \text{ charge}) = 5 + 18 + 1 = 24 \text{ electrons}$$

Calculate S , total number of electrons shared in the molecule or ion, using the relationship

$$S = n - A$$

For PF_3 , $S = n - A = 32 - 26$

$= 6 \text{ electrons shared (3 pairs of electrons shared)}$

For NO_3^-

$$S = n - A = 32 - 24 = 8 \text{ electrons shared (4 pairs of electron shared)}$$

(3) Place S the electrons into the skeleton as shared pair's. Use double and triple bonds only when necessary. Lewis formulas may be shown as either dot formula or dash formulas.

Formula	Skeleton	Dot Formula ("bonds" in place, but incomplete)	Dash Formula ("bonds" in place, but incomplete)
PF ₃	$\begin{array}{ccc} \text{F} & \text{P} & \text{F} \\ & & \text{F} \end{array}$	$\begin{array}{ccc} \text{F} & : \text{P} : & \text{F} \\ & & \text{F} \\ & & \vdots \\ & & \text{F} \end{array}$	$\begin{array}{ccc} \text{F} & - \text{P} - & \text{F} \\ & & \\ & & \text{F} \end{array}$
CH ₃ OH	$\begin{array}{cccc} & \text{H} & & \\ \text{H} & \text{C} & \text{O} & \text{H} \\ & \text{H} & & \end{array}$	$\begin{array}{ccc} \text{H} & & \\ \text{H} : & \text{C} : & \text{O} : \text{H} \\ & & \vdots \\ & & \text{H} \end{array}$	$\begin{array}{ccc} \text{H} & & \\ \text{H} - & \text{C} - & \text{O} - \text{H} \\ & & \\ & & \text{H} \end{array}$
NO ₃ ⁻	$\left[\begin{array}{ccc} & \text{O} & \\ \text{O} & \text{N} & \text{O} \\ & & \end{array} \right]^{-}$	$\left[\begin{array}{ccc} & \text{O} & \\ \text{O} : & \text{N} : & \text{O} \\ & & \vdots \\ & & \text{O} \end{array} \right]^{-}$	$\left[\begin{array}{ccc} & \text{O} & \\ \text{O} & \text{N} = & \text{O} \\ & & \vdots \\ & & \text{O} \end{array} \right]^{-}$

4) Place the additional electrons into the skeleton as unshared (lone) pairs to fill the octet of every A group element (except H, which can share only 2 electrons) check that the total number of valence electrons is equal to A from step 2.

For example: for PF₃,

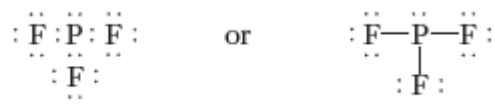

Check: 13 pairs of electrons have been use and all octets are satisfied. $2 \times 13 = 26$ electrons available

For CH₃OH,

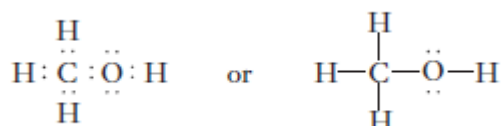

Check: 7 electrons have been used and all octets are satisfied . $2 \times 7 = 14$ electrons available

For NO₃⁻,

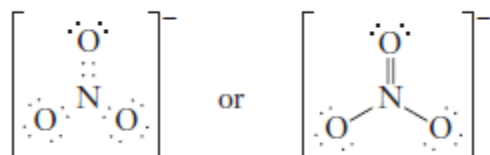

Check: 12 pairs of electrons have been used and all octets are satisfied. $2 \times 12 = 24$ electrons available.

(5) Check that you have the lowest **formal charges (f.c.)** possible for all the atoms, without Violating the octet rule; **F.C. = (valence e-) - (1/2 bonding e-) - (lone electrons).**

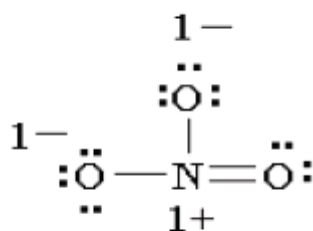
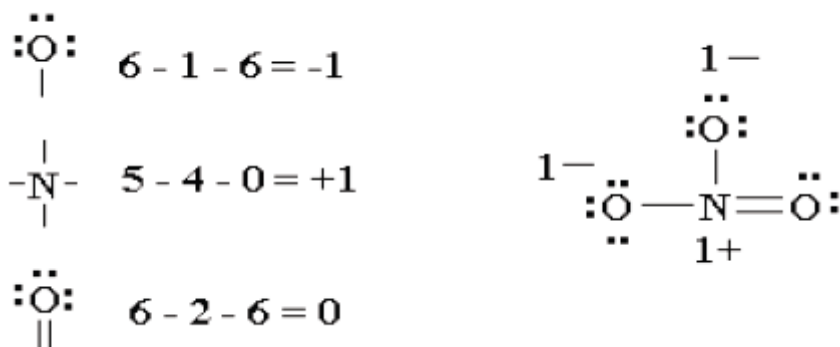

Thus the Lewis structure of NO_3^- ion can be written in the following ways:

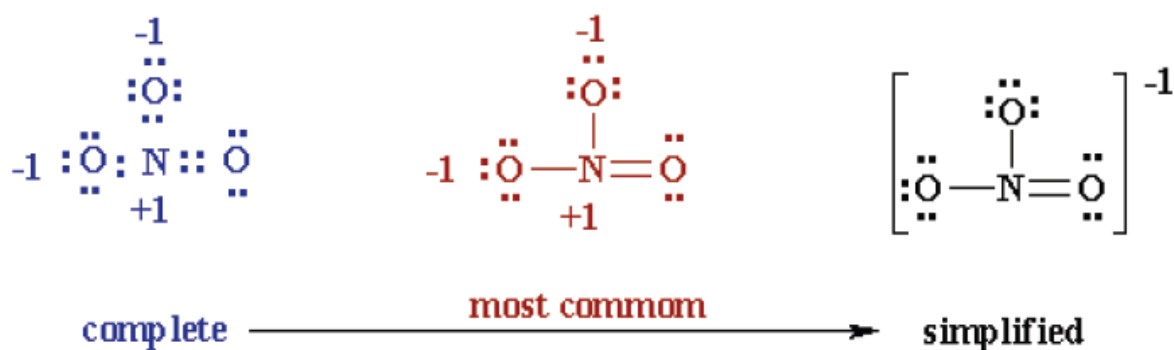

2. Draw the Lewis diagram for nitrogen molecule (N_2) and carbonate ion (CO_3^{2-}) by using the rules indicated above?

Note that this is another alternative method that can be used to determine the Lewis structures.

Solution

Write the Lewis structure for the nitrogen molecule, N_2

Step 1: the skeleton of N_2 is N N

Step 2: $\text{N} = 2 \times 8 = 16e^-$ needed by both atoms

$\text{A} = 2 \times 5 = 10e^-$ available (total) for both atoms

$\text{S} = \text{N} - \text{A} = 16e^- - 10e^- = 6e^-$ shared

Step 3: $6e^-$ shared (3 pairs) shared

Step 4: the 4 additional electrons are accounted for by a lone pair on each nitrogen atom

The complete Lewis structure is

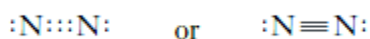

Check: $10e^-$ (5 pairs have been used).

3. Write the Lewis formula for the carbonate, CO_3^{2-}

Plan

The same stepwise procedure can be applied to ions. We must remember to adjust A, the total number of electrons, to account for the charge shown on the ion

Solution

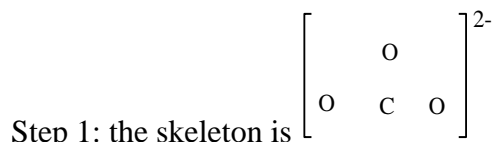

Step 2: $N = 1 \times 8$ (for C) + 3×8 (for O) = $8 + 24 = 32e^-$ needed by all atoms

$A = 1 \times 4$ (for C) + 3×6 (for O) + 2 (for the 2- charge)

= $4 + 18 + 2 = 24e^-$ available

$S = N - A = 32e^- - 24e^- = 8e^-$ (4 pairs) shared

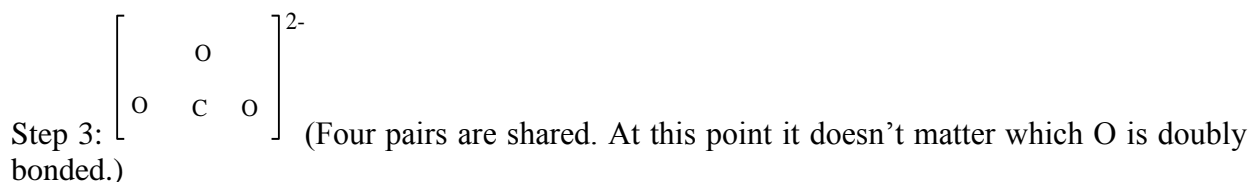

Step 4: the Lewis formula is

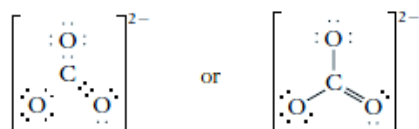

Check: $24e^-$ (12 pairs) have been used.

Checking up 4.2(a)

1 What do you consider when drawing Lewis structures of different molecules?

2 Draw the Lewis diagram for the following compounds

(a) PCl_3 (b) H_2S (c) CH_3Cl (d) C_2H_2

3 What is meant by the term Lewis structure?

4. Using water, differentiate between Lewis structures from other structures.

5. Deduce the importance of Lewis structures in covalent molecules. What criticisms can you make to those structures?

Exceptions to the octet rule

Activity 4.2(b)

1. Draw the Lewis structure of aluminium chloride (AlCl_3)?

2. How many electrons surround the aluminium atom in the centre?

3. Does it obey the octet rule? And why?

There are **three general ways** in which the octet rule doesn't work:

- Molecules with an odd number of electrons
- Molecules in which an atom has less than an octet

- Molecules in which an atom has more than an octet

(a) Odd number of electrons

Consider the example of the Lewis structure for the molecule nitrous oxide (NO):

Total electrons: $6+5=11$



Bonding structure:

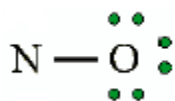

(3) Octet on "outer" element:

(4) Remainder of electrons ($11-8 = 3$) on "central" atom:

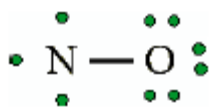

(5) There are currently 5 valence electrons around the nitrogen. A double bond would place 7 around the nitrogen, and a triple bond would place 9 around the nitrogen.

We appear unable to get an octet around each atom.

(b) Less than an octet (*most often encountered with elements of Boron and Beryllium*)

Consider the example of the Lewis structure for boron trifluoride (BF₃):

1. Add electrons (3×7) + 3 = 24
2. Draw connectivities

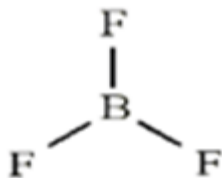

3. Add octets to outer atoms



4. Add extra electrons ($24 - 24 = 0$) to central atom:

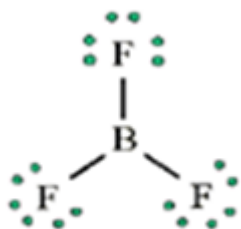

5) Does central atom have octet? No, it has 6 electrons. Add a multiple bond (double bond) to see if central atom can achieve an octet:

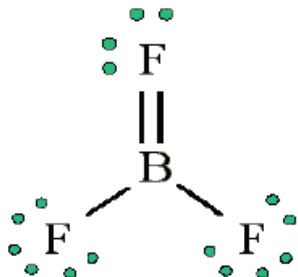

(6) The central Boron now has an octet (there would be three resonances Lewis structures). However, in this structure with a double bond the fluorine atom is sharing extra electrons with the boron.

The fluorine would have a **positive** partial charge, and the boron a **negative** partial charge, this is inconsistent with the electronegativities of fluorine and boron.

Thus, the structure of BF_3 , with single bonds, and 6 valence electrons around the central boron is the most likely structure.

BF_3 reacts strongly with compounds which have an unshared pair of electrons which can be used to form a σ bond with the boron. Example: Reaction of BF_3 with ammonia

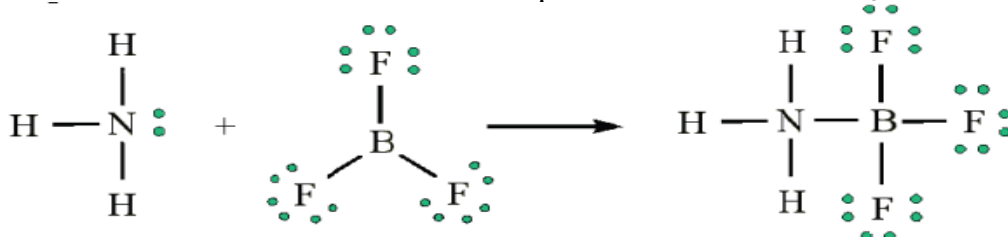

NH_3

(c) More than an octet (*most common example of exceptions to the octet rule*)

PCl_5 is a legitimate compound, whereas NCl_5 is not.

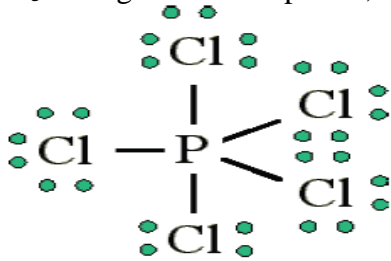

Expanded valence shells are observed only for elements in **period 3** (i.e. $n=3$) and beyond.

The '**octet**' rule is based upon available **ns** and **np-orbitals** for valence electrons (2 electrons in the s orbitals, and 6 in the p orbitals). Beginning with the $n=3$ principal quantum number, the d-orbitals become available ($\ell=2$)

The box orbital representation for the valence shell of phosphorous is:



(Third period elements occasionally exceed the octet rule by using their empty d-orbitals to accommodate additional electrons)

Size is also an important consideration: **“The larger the central atom, the larger the number of electrons which can surround it”**. Expanded valence shells occur most often when the central atom is bonded to small electronegative atoms, such as F, Cl and O.

Example: Draw the Lewis structure for ICl_4^-

(1) Count up the valence electrons: $7 + (4 \times 7) + 1 = 36$ electrons

(2) Draw the connectivities:

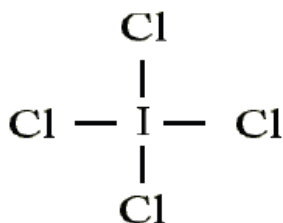

Add octet of electrons to outer atoms:

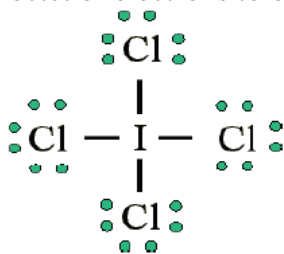

(4) Add extra electrons ($36-32=4$) to central atom:

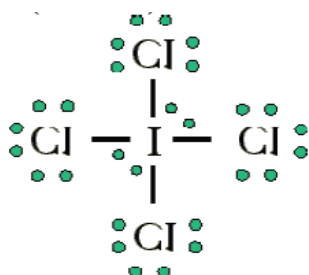

(5) The ICl_4^- ion thus has 12 valence electrons around the central Iodine (in the 5d orbitals)

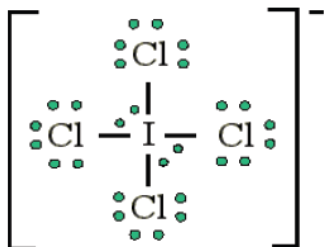

Checking up 4.2(b)

1. Draw the Lewis diagram for the following species
(a) SOCl_2 (b) ICl_4^- (c) SO_4^{2-} (d) CH_3OH
2. During sharing of electrons some elements can accommodate more than eight electrons in their outer shell while other becomes comfortable with less than eight electrons on the observation with reference to BeCl_2 and PCl_5 .

4.3 Coordinate or dative covalent bonding, properties and resonance structures

Activity 4.3

1. Write the electronic configuration of (i) nitrogen atom (ii) aluminium atom (ii) oxygen atom using s, p, d.. notation.
2. Draw the Lewis structures of water molecule (H_2O), Aluminium Chloride (AlCl_3), ammonia molecule (NH_3) and carbon dioxide (CO_2)
3. During formation of hydroxonium ion (H_3O^+) Water (H_2O) combine with Hydrogen ion (H^+). Draw the electronic structure to show how the electrons are shared.
4. Aluminium chloride in vapor phase exists as Al_2Cl_6 . Draw the Lewis structure indicating all the bonds.
5. Using diagrams, suggest how sharing of electrons take place during the formation of ammonium ion (NH_4^+) from ammonia (NH_3) and (H^+) ion

4.3.1. Co-ordinate or dative covalent bonding, propertie

A **dative covalent bond**, or **coordinate bond** is another type of covalent bonding. In this case, the shared electron pair(s) are completely provided by one of the participants in the union, and not by contributions from the two of them. The contributors of the shared electrons are either **neutral molecules** which contain lone pair(s) of electrons on one of their atoms, or **negatively charged groups** with free pairs of electrons to donate.

Examples: $\text{H}_2\ddot{\text{O}}:$, $:\text{NH}_3$ and CN^- .

Based on the reaction between **ammonia** and **hydrogen chloride** a coordinate bond takes place forming a solid ammonium chloride according to the chemical equation below.



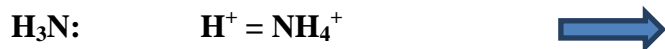

In this reaction the hydrogen ion from the hydrogen chloride leaves its electrons and gets transferred to the lone pair of electrons on the ammonia molecule forming ammonium ions (NH_4^+) as shown by the diagram below. This is known as *a coordinate bonding*.

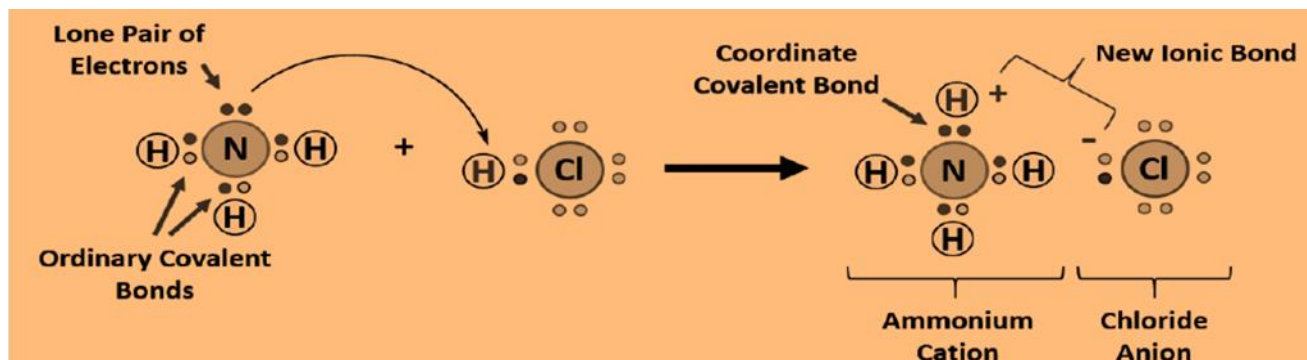

Figure 4.6: Formation of coordinate bond between ammonia and hydrogen chloride

Note: The compound formed comprises three types of bonding such as *covalent*, *coordinate* and *electrovalent*.

Another example comprising co-ordinate bond is the *reaction between ammonia and boron trifluoride*. Boron trifluoride (BF_3) is an electron deficient (Lewis acid) because it has 3 pairs of electrons at its bonding level but it is capable of having four pairs. For that kind of reaction, the *ammonia is used to supply this extra lone pair* (Lewis base). A coordinate bond is formed where the lone pair from the nitrogen moves towards the boron. The end containing the nitrogen will therefore become more positive while the boron end will become more negative because it has received electrons.

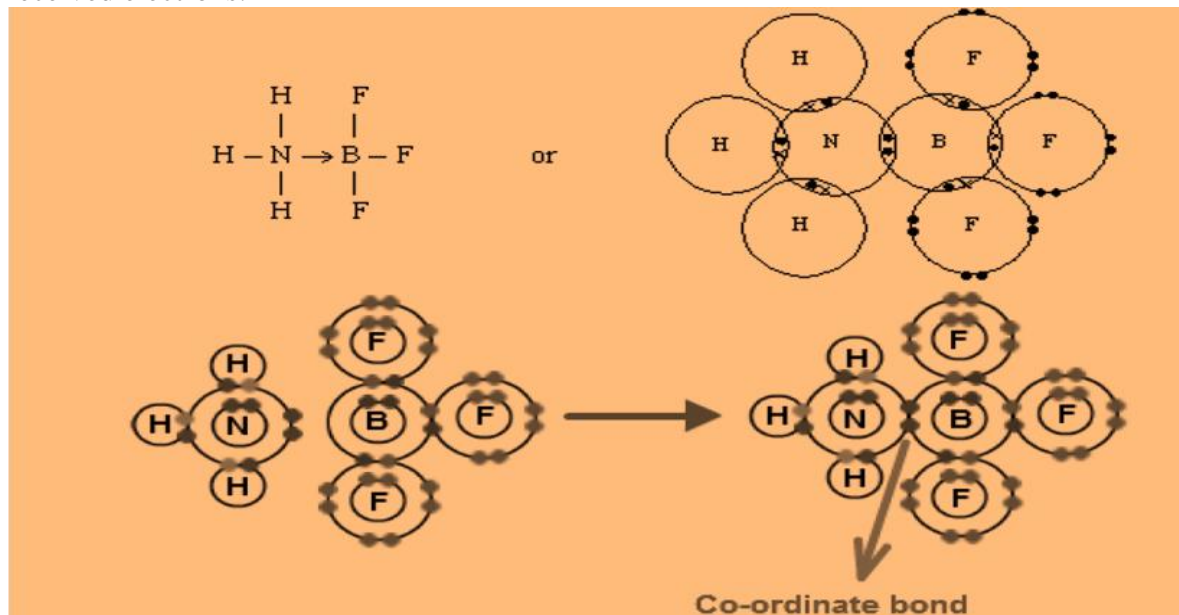

Figure 4.7: Formation of dative covalent bond between ammonia and boron trifluoride

4.3.2. Dative covalent bonding in complex ions

A complex ion consists of a central metal cation bonded to a group of atoms, molecules or ions which are known as ligands through co-ordinate bonds.

Example

When dilute solution of aqueous ammonia is added to aqueous copper (II)sulphate, a blue precipitate of copper II hydroxide is initially formed. If an excess of ammonia is added, the blue precipitate dissolves to give a clear dark blue solution.

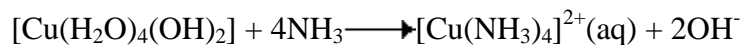
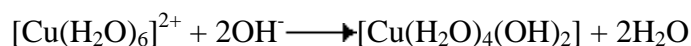

The solid copper (II) hydroxide which was initially formed reacts with the excess ammonia (which acts as ligands) to form the water soluble tetra ammine copper (II) complex as shown below.

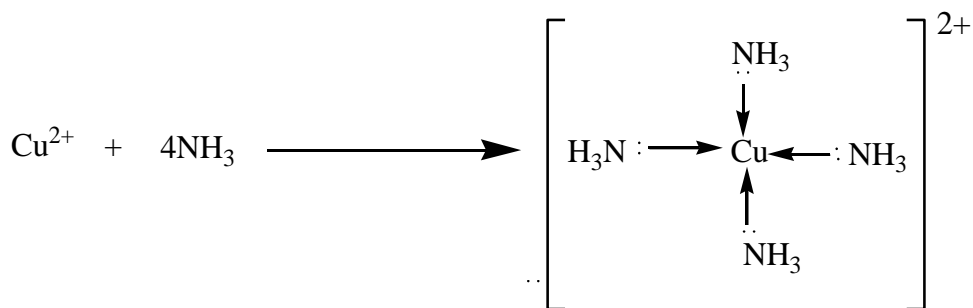

Or

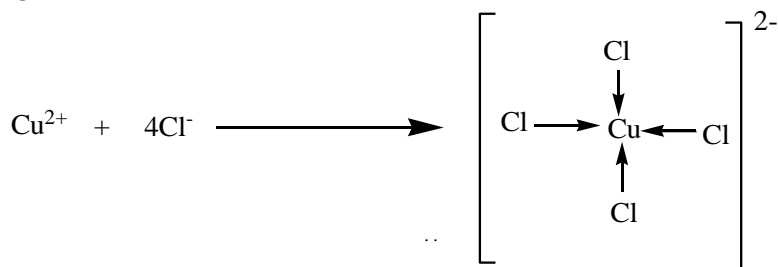

In complex ion formation, the central metal cation must have empty orbitals while the ligands must have a lone pair of electrons for the co-ordinate bond to be formed as indicated below.

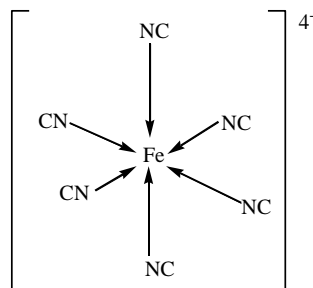

Checking up 4.3

1. Draw diagrams to show how the dative covalent bond when water combines with Hydrogen ion to form hydroxonium ion (H_3O^+)
2. Draw the Lewis structures for the following species
(a) NO_2 (b) N_2O_4 (c) AlCl_3
3. Suggest the properties of dative covalent bond and state how it differs from normal covalent bonds.
4. Use the Lewis diagram for aluminium chloride AlCl_3 drawn in 2(c) above to identify and label the dative covalent bonds and normal covalent bonds.
6. What do you understand by the term co-ordinate (dative covalent bond)?
7. Describe with examples how a dative covalent bond is formed using a specific example of your choice.
8. How does a dative covalent bond differ from a normal covalent bond?
9. Biological molecules such as hemoglobin contain iron cation in the center surrounded by oxygen ligands. Suggest reasons why is this important to us?

4.4 Valence bond theory (VBT)

Activity 4.4

1. Draw the diagram to show how the single and double bonds are formed in:
(i) Oxygen molecule (O_2) (ii) nitrogen molecule (N_2) (iii) ethane molecule (C_2H_4)
2. Use valence bond theory to explain the formation of the above molecules.
3. Explain how sigma and pi bonds are formed using valence bond theory.

Valence Bond theory describes covalent bond formation as well as the electronic structure of molecules. The theory assumes that electrons occupy the atomic orbitals of individual atoms within a molecule, and that the electrons of one atom are attracted to the nucleus of another

atom. The valence bond theory was proposed by Heitler and Fritz London to explain the formation of covalent bonds quantitatively using quantum theory of mechanics. Later on Linus Pauling modified the theory by introducing the concept of hybridization theory. However the old version of valence bond theory is limited to diatomic molecules only. It could not explain the shapes and bond angles of molecules with more than three atoms. E.g. H_2O , NH_3 etc.

The main postulates of this theory are as follows:

- A covalent bond is formed by the overlapping of two half-filled valence atomic orbitals of two different atoms.
- The electrons in the overlapping orbitals get paired and confined between the nuclei of two atoms.
- The electron density between two bonded atoms increases due to overlapping. This confirms the stability of the molecule.
- The greater the extent of overlapping the stronger is the covalent bond
- The direction of the covalent bonding is along the region of overlapping of the atomic orbitals. i.e. covalent bond is directional.
- There are two types of covalent bonds based on the pattern of overlapping.

Types of covalent bonds based on overlapping of orbitals

There are two types of overlapping: sigma (σ) and pi (π). Both bonds are formed from the overlapping of two orbitals, one on each atom.

σ bonds occur when orbitals overlap between the nuclei of two atoms, also known as the internuclear, or head-to-head overlapping and is said to possess a cylindrical symmetry. π bond occurs when two (unhybridized) p-orbitals overlap side-by-side. In π bond, the electron cloud is not between the two nuclei; it is located above and below the inter-nuclear axis. By occupying the region of space that is above and below the internuclear axis, the attraction between the nuclei and electrons is not as effective as in a sigma bond.

(i) Sigma (σ) bond is a stronger bond and cylindrically symmetrical. The σ -bond is divided into the following types:

- **σ_{s-s} bond where s orbitals are involved as shown in the example below.**

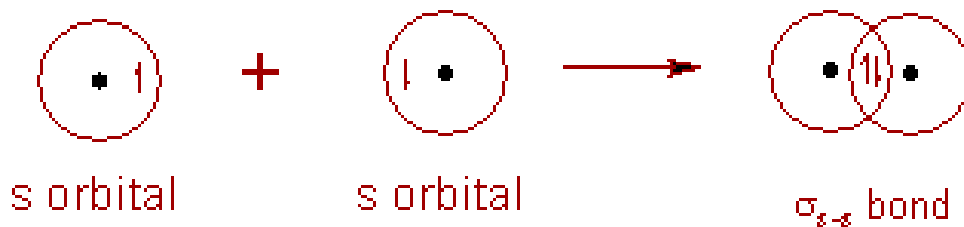

- **σ_{s-p} bond where orbitals s and p are involved as shown in the formation of HCl below.**

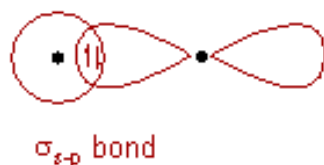

Example of s-p bond in hydrogen chloride (H-Cl)

- σ_{p-p} bond where p orbitals are involved as shown in the example below

Head-to-head overlapping or axial overlapping

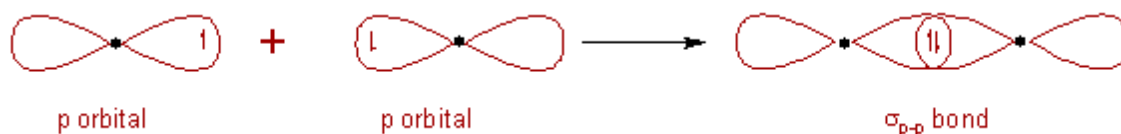

Example: Chlorine molecule: Cl-Cl (Cl_2)

1) Formation of H_2 molecule:

The electronic configuration of hydrogen atom in its ground state is $1s^1$. It is seen in the picture below that two half-filled $1s$ orbitals of hydrogen atoms overlap along the inter-nuclear axis by forming a σ_{s-s} bond.

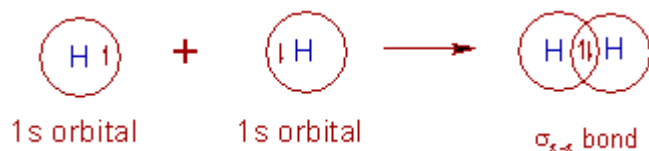

2) Formation of HCl molecule: In the ground state, the electronic configuration of hydrogen atom is $1s^1$ and that of Cl atom is $[\text{Ne}]3s^2 3p_x^2 3p_y^2 3p_z^1$. The half-filled $1s$ orbital of hydrogen overlap with the half-filled $3p_z$ atomic orbital of chlorine atom along the inter-nuclear axis to form a σ_{s-p} bond as seen below.

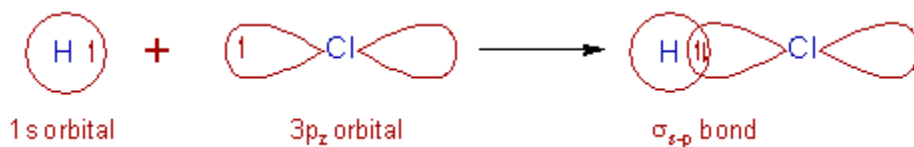

3) Formation of Cl_2 molecule: The electronic configuration of Cl atom in the ground state is $[\text{Ne}]3s^2 3p_x^2 3p_y^2 3p_z^1$. The two half-filled $3p_z$ atomic orbitals of two chlorine atoms overlap along the inter-nuclear axis, forming a σ_{p-p} bond as shown below.

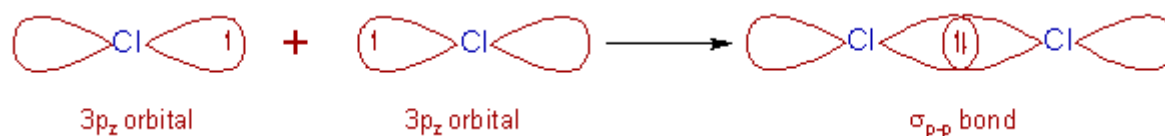

(ii) Pi (π)-bond is a covalent bond formed by sidewise (side-by-side, lateral) overlapping of p or d atomic orbitals. In this bond, the electron density is above and below the inter-nuclear axis. It is relatively a weaker bond since the electrons are not strongly attracted by the nuclei of bonding atoms. π_{p-p} bond is shown in the following example:

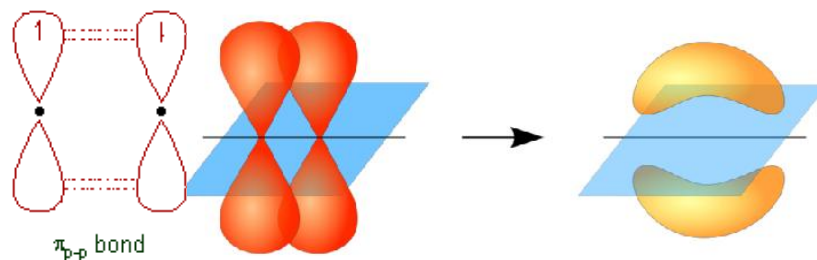

1) Formation of O_2 molecule: The electronic configuration of O in the ground state is $[He] 2s^2 2p_x^2 2p_y^1 2p_z^1$. The half-filled $2p_y$ orbitals of two oxygen atoms overlap along the inter-nuclear axis and form σ_{p-p} bond. The remaining half-filled $2p_z$ orbitals overlap laterally to form a π_{p-p} bond. Thus a double bond (one σ_{p-p} and one π_{p-p}) is formed between the two oxygen atoms.

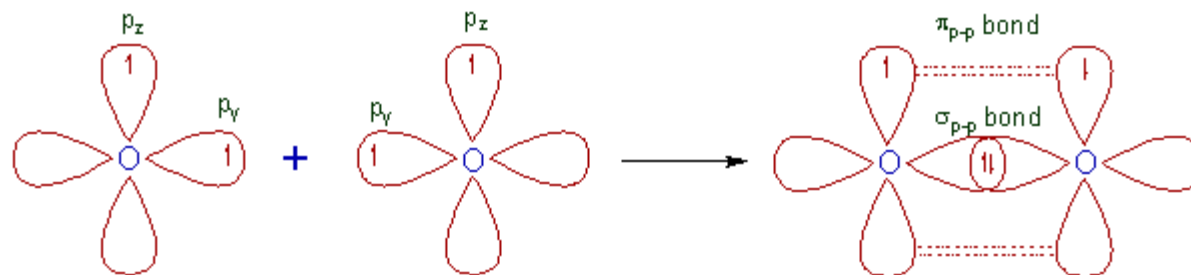

2) Formation of N_2 molecule:

The ground state electronic configuration of N is $[He] 2s^2 2p_x^1 2p_y^1 2p_z^1$. A σ_{p-p} bond is formed between two nitrogen atoms due to overlapping of half-filled $2p_x$ atomic orbitals along the inter-nuclear axis. The remaining half-filled $2p_y$ and $2p_z$ orbitals form two π_{p-p} bonds due to lateral overlapping. Thus a triple bond (one sigma and two pi) is formed between two nitrogen atoms.

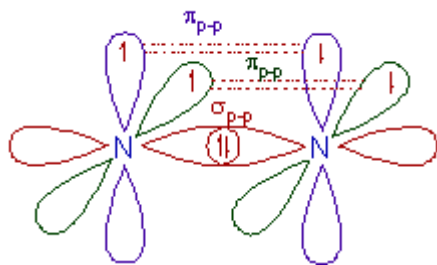

Checking Up 4.4

- Describe the aspects and postulates of valence bond theory (VBT)
- Use VBT to explain the formation of single (sigma) and double (pi) bonds
 - Explanation of lateral overlap of atomic orbitals and
 - Explanation of head-to-head overlap of atomic orbitals

4.5. Valence Shell Electron Pair Repulsion Theory (VSEPR) theory

Activity 4.5

- What is VSEPR in full?
- Draw the Lewis structures of water (H_2O), ammonia (NH_3) and identify the areas with high density.
- In groups carry out the activity
 - Get students into groups of 2 or 3 and pass out balloons and strings and scissors
 - Ask students to create visuals of molecular orbitals with balloons
 - Blow up 2 balloons and tie them together
 - Do the same thing with 3 balloons, 4 balloons, 5 balloons, and 6 balloons
 - Meet back as a class and have each group show their models and name the molecular geometry

Why VSEPR Theory?

There is no direct relationship between the formula of a compound and the shape of its molecules; in other words, looking at chemical formula of compound does not allow you to know the shape or geometry of the molecule.

In order to predict the geometry of molecules, *Nyholm* and *Gillespie* developed a qualitative model known as **Valence Shell Electron Pair Repulsion Theory (VSEPR Theory)**

The basic assumptions of this theory are summarized below.

1) The electron pairs in the valence shell around the central atom of a molecule repel each other and tend to orient in space so as to minimize the repulsions and maximize the distance between them.

2) There are two types of valence shell electron pairs such as Bond pairs and Lone pairs.

Bond pairs are shared by two atoms and are attracted by two nuclei. Hence they occupy less space and cause less repulsion.

Lone pairs are not involved in bond formation and are in attraction with only one nucleus. Hence they occupy more space. As a result, the lone pairs cause more repulsion.

The *order of repulsion* between different types of electron pairs is as follows:

Lone pair - Lone pair > Lone Pair - Bond pair > Bond pair - Bond pair

The bond pairs are usually represented by a solid line, whereas the lone pairs are represented by a lobe with two electrons.

3) In VSEPR theory, the multiple bonds are treated as if they were single bonds. The electron pairs in multiple bonds are treated collectively as a single super pair.

The repulsion caused by bonds increases with increase in the number of bonded pairs between two atoms i.e., a triple bond causes more repulsion than a double bond which in turn causes more repulsion than a single bond.

4) The shape of a molecule can be predicted from the **number** and **type** of valence shell electron pairs around the central atom.

The principle of the VSEPR is based on the idea that: **the most stable structure of a molecule is the one where the electron pairs are far away one from another in order to minimize the repulsions between the pairs of electrons surrounding the central atom.**

The VSEPR theory assumes that each atom in a molecule will achieve a geometry that minimizes the repulsion between electrons in the valence shell of that atom. The use of VSEPR involves the following steps:

- Draw a Lewis structure for the ion or molecule in question.
- The shape is based on the location of the nuclei in a molecule, so double and triple bonds count as one shared pair when determining the shape of the molecule
- Locate the shared pairs and lone pairs on the central atom
- Determine the shape based on the molecules

Examples:

BeCl₂: minimum repulsion of electrons: linear structure:

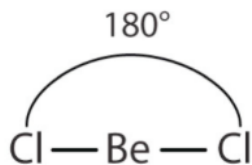

AlCl₃: minimum repulsion of electrons: trigonal planar or equilateral triangle:

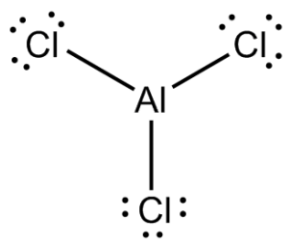

CH₄: minimum repulsion of electrons: tetrahedral

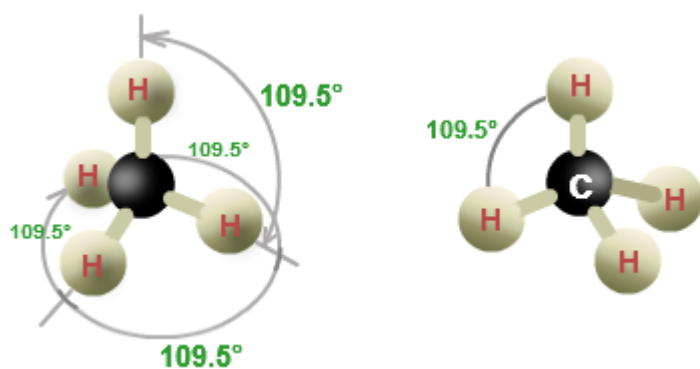

Although this theory has allowed to explain a certain number of molecular structures, it remains qualitative. That is why other concepts have been introduced to explain the structures and shapes of molecules.

4.6. Types of Hybridization

Activity 4.6

1. Write the electronic configuration of carbon and hydrogen using s,p, d.. Notation.
2. Use the electronic configurations above to identify the orbitals that contain electrons used during the formation of methane.
3. Use the knowledge of overlap of orbitals to indicate how orbitals overlap in formation of hydrogen chloride, methane and beryllium chloride.

Hybridization is a mathematical operation consisting in mixing atomic orbitals (which are mathematical functions) to generate new orbitals called “hybridized atomic orbitals”. This textbook will not develop the mathematical aspect of hybridization, only the results of that operation will be used.

But why hybridization?

The concept of hybridization has been developed to explain shapes of molecules that cannot be explained by overlapping pure atomic orbitals.

For example: how can you explain that carbon with electronic structure: $1s^2 2s^2 2p_x^1 2p_y^1 2p_z^0$, can form methane molecule CH_4 , with a tetrahedral shape? It is only by using the concept of hybridization of atomic orbital that the answer is found.

1. sp Hybridization

This type of hybridization involves mixing of one ‘s’ orbital and one ‘p’ orbital of similar energy to give a new hybrid orbital known as an sp hybridized orbital. When two orbitals are hybridized, they general two hybridized new orbitals. sp hybridization forms a linear shape or structure where the two new orbitals form 180° .

Example 1. The element Be has 4 electrons and its electronic configuration in ground state is $1s^2 2s^2$. BeCl_2 is linear, Cl-Be-Cl ; this cannot be explained by using pure atomic orbital of Be. But through sphybridisation on Be atom, two new atomic hybridized orbitals, sp , are generated. The two s^2 electrons can now be distributed one in each hybridized orbital and this allows Be to form two linear sigma bonds around it as shown below.

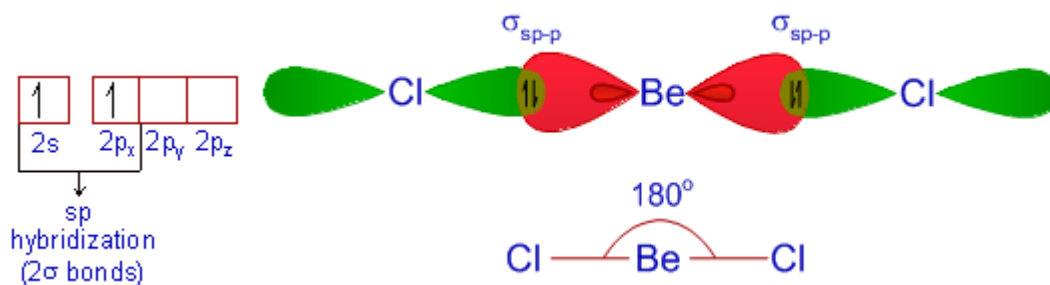

2. sp^2 Hybridization

This type of hybridization involves mixing of one ‘s’ orbital and two ‘p’ orbitals to give 3 new hybrid orbitals known as sp^2 . This kind of hybridization results into a trigonal planar structure (equilateral triangle), with an angle of 120° between the hybridized orbitals, as shown below.

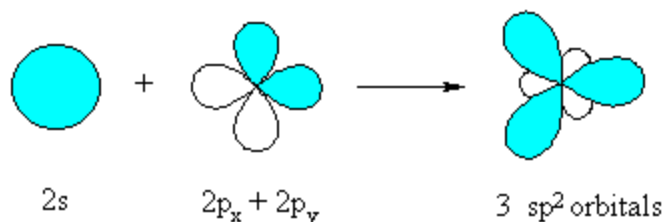

This is the case of ethylene (C_2H_4). During the formation of ethylene molecule, each carbon atom undergoes sp^2 hybridization by mixing one $2s$ orbital and two $2p$ orbitals to give three half-filled sp^2 hybrid orbitals oriented in trigonal planar symmetry. There is also one half-filled unhybridized $2p_z$ orbital on each carbon perpendicular to the plane of sp^2 hybrid orbitals

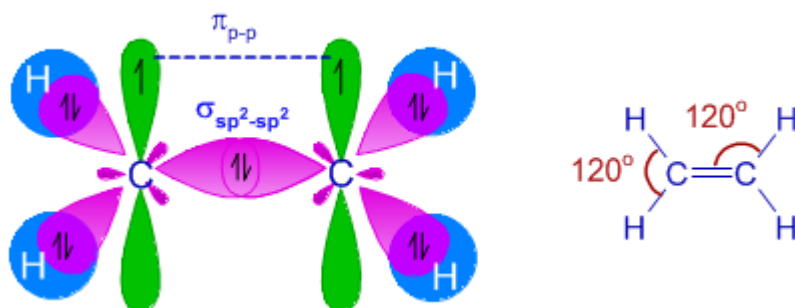

The carbon atoms form a $\sigma_{sp^2-sp^2}$ bond with each other by using sp^2 hybrid orbitals. A π_{p-p} bond is also formed between them due to lateral overlapping of unhybridized $2p_z$ orbitals. Thus there is a double bond ($\sigma_{sp^2-sp^2}$ and π_{p-p}) between two carbon atoms. Each carbon atom also forms two σ_{sp^2-s} bonds with two hydrogen atoms. Therefore, ethylene molecule is planar with angles equal to 120° .

3. sp^3 Hybridization

This type involves mixing of one 's' orbital and three 'p' orbitals to give four new hybrid orbitals known as sp^3 . Hybridization of one s and three p orbitals forms a tetrahedral with an angle of 109.5° between the new orbitals; this angle is often called tetrahedral angle.

After hybridization, the four valence electrons are distributed in the four orbitals one by one and this allow the carbon atom to form 4 identical C-H sigma bonds. That is how the tetrahedral structure of methane, CH_4 , can be explained.

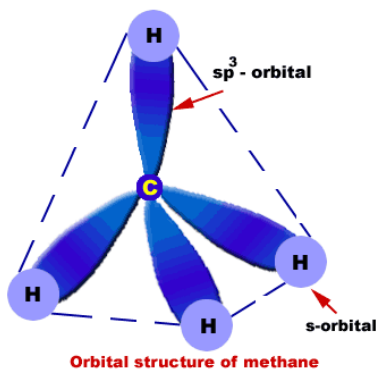

(<https://www.quora.com/What-are-the-example-of-sp³-hybridisation>)

During the formation of methane molecule, the carbon atom undergoes sp^3 hybridization by mixing one '2s' and three 2p orbitals to form four half-filled sp^3 hybrid orbitals, which are oriented in tetrahedral symmetry in space around the carbon atom. Each of these sp^3 hybrid orbitals forms a σ_{sp^3-s} bond with one hydrogen atom. Thus carbon forms four σ_{sp^3-s} bonds with four hydrogen atoms. Methane molecule is tetrahedral in shape with $109^\circ 50'$ bond angle.

4. sp^3d Hybridization

This type of hybridization involves mixing of one 's' orbital, three 'p' orbitals and one 'd' orbital to give a 5 new hybrid orbitals known as sp^3d hybridized orbitals. The 5 new hybridised orbitals form trigonal bipyramidal geometry as shown in the example below. Three of the hybrid orbitals lie in horizontal plane at angle of 120° to one another.

Example: Formation of Phosphorus pentachloride (PCl_5)

The ground state electronic configuration of phosphorus atom is: $1s^2 2s^2 2p^6 3s^2 3p_x^1 3p_y^1 3p_z^1$. The formation of PCl_5 molecule requires 5 unpaired electrons. Hence the phosphorus atom undergoes excitation to promote one electron from 3s orbital to one of empty 3d orbital.

Thus the electronic configuration of 'P' in the excited state is $1s^2 2s^2 2p^6 3s^1 3p_x^1 3p_y^1 3p_z^1 3d^1$.

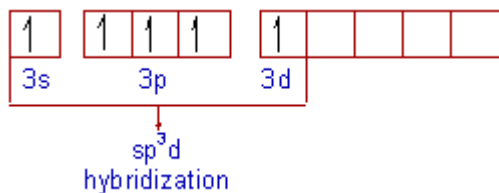

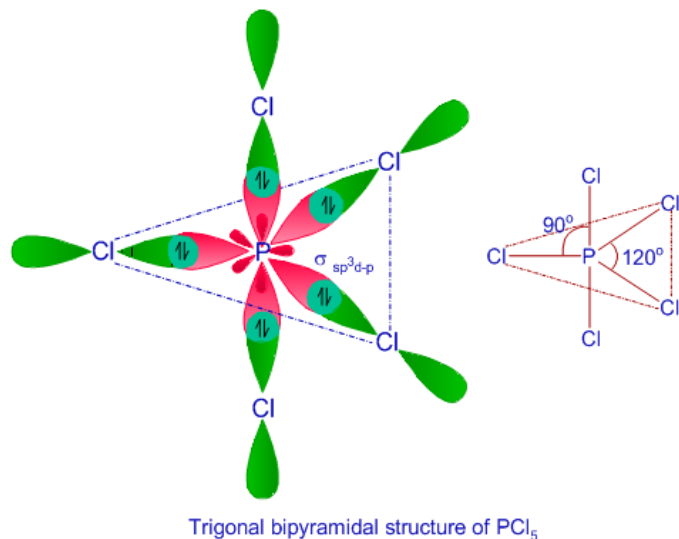

5. sp^3d^2 Hybridization

In this type of hybridization one s, three p and two d-orbitals undergo intermixing to form six identical sp^3d^2 hybrid orbitals. These six orbitals are directed towards the corners of an octahedron and lie in space at an angle of 90° to one another.

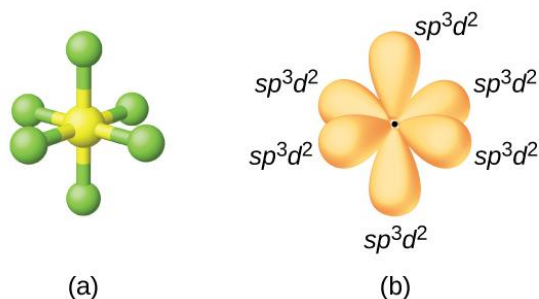

(<https://chemistryonline-guru/hybridisation-2/>)

Example: Formation of Sulfur hexafluoride (SF_6)

The electronic configuration of 'S' in ground state is $1s^2 2s^2 2p^6 3s^2 3p_x^2 3p_y^1 3p_z^1$. In SF_6 molecule, there are six bonds formed by sulfur atom. Hence there must be 6 unpaired electrons. However there are only 2 unpaired electrons in the ground state of sulfur. Hence it promotes two electrons into two of the 3d orbitals (one from 3s and one from $3p_x$). Thus the electronic configuration of 'S' in its 2nd excited state is $1s^2 2s^2 2p^6 3s^1 3p_x^1 3p_y^1 3p_z^1 3d^2$.

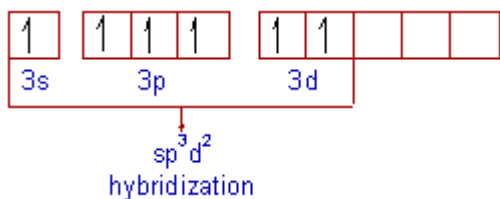

In the second excited state, sulfur undergoes sp^3d^2 hybridization by mixing a 3s, three 3p and two 3d orbitals. Thus formed six half-filled sp^3d^2 hybrid orbitals are arranged in octahedral symmetry. Sulfur atom forms six $\sigma_{sp^3d^2-p}$ bonds with 6 fluorine atoms by using these sp^3d^2 orbitals. Each fluorine atom uses its half-filled $2p_z$ orbitals for the bond formation. SF_6 is octahedral in shape with bond angles equal to 90° .

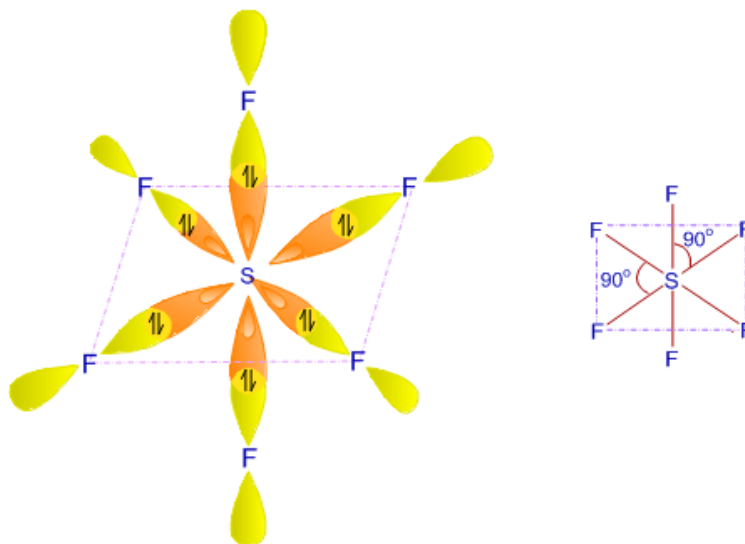

octahedral structure of sulfur hexafluoride

Summary of hybridization

Mixed Orbitals	Atomic Orbitals	Formed Hybrid Orbitals	Hybridization	Shape
One s and one p orbital		sp	sp-hybridization	Linear
One s and two p orbitals		sp^2	sp^2 -hybridization	Trigonal planar/equilateral triangle
One s and three p orbitals		sp^3	sp^3 -hybridization	Tetrahedral
One s and three p and one d orbitals		sp^3d	sp^3d -hybridisation	Trigonalbipyramidal
One s and three p and two d orbitals		sp^3d^2	sp^3d^2 -hybridisation	Octahedral

Checking up 4.6

1. What is the importance of hybridization of atomic?
2. Using carbon describe the three types of hybridization.

3. Give some examples of molecules that are sp , sp^2 , sp^3 and sp^3d hybridized.
4. What criteria do you consider when predicting the type of hybridization

What are hybrid orbitals?

What are characteristics of hybrid orbitals?

What is meant by the term “hybridising” of atomic orbitals?

10. Why atomic orbitals in a given atom undergo hybridization?

11. Explain how the type of hybridization is related to the shape of the molecule

12. Draw dots-and-crosses diagrams (showing outer electrons only) for the following:

a) Oxygen, O_2

b) Carbon dioxide, CO_2

c) Methanal (formaldehyde). You are unlikely to be familiar with this compound yet. Its molecular formula is CH_2O . You will have to play around to work out how it is joined up. Make sure that you make the maximum possible number of bonds.

d) Ethene, C_2H_4

13. This question looks in detail at the bonding in ethene from a modern point of view. Although your syllabus may say that you don't need to know about hybridization, you still need to know the end result. It is much better if you can understand how the modern view of ethene arises.

a) Write down the electronic structure of carbon in s and p notation.

b) Show what happens when the atom is excited and an electron promoted.

c) Before the carbon atoms bond to each other and to hydrogen atoms to make ethene, they undergo hybridization. What does this mean, and how are the electrons arranged once this has happened?

d) We think of the next stage as the formation of sigma bonds between the two carbon atoms and the carbons and hydrogens. What are sigma bonds, and how are they formed?

e) Finally, we picture the formation of a pi bond between the two carbon atoms. How does this form, and how is it different from a sigma bond?

4.7 Polarity of the covalent bonds

Activity 4.7

1. Can you define the term electronegativity?

2. How is electronegativity related to polarity of the compound?

3. How does the polarity of a given molecule affect its physical properties?

4. Can you describe the general trends of electronegativity across and down the groups in the periodic table?

5. What is meant by the term dipole and Net dipole

In a polar covalent bond, a pair of electrons is unequally shared between two atoms. The power of an atom to attract the pair of electrons that constitute the bond in a molecule is termed as electronegativity.

The '*electronegativity*' can be used to determine whether a given bond is *non-polar covalent*, *polar covalent*, or *ionic bond*. The electronegativity *increases from left to right* along a period and *decreases as you go down* a group

The larger the electronegativity, the greater is the strength to attract a bonding pair of electrons.

If we consider the molecule of F_2 , the electrons are shared equally between the atoms and the bond is called a non-polar covalent. However, in HF the fluorine atom has greater electronegativity than the hydrogen atom. The sharing of electrons in HF is unequal: the electron pair that is bonding HF together shifts towards the fluorine atom because it has a larger electronegativity value and there is a polar covalent bond. The fluorine end becomes partially negatively charged and the hydrogen end becomes partially positively charged. The H-F bond can be represented as follows.

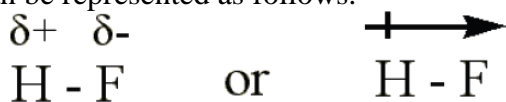

The ' $\delta+$ ' and ' $\delta-$ ' symbols indicate partial positive and *negative charge* respectively.

The arrow indicates the "**pull**" of electrons off the hydrogen and towards the *more electronegative* atom, fluorine.

The following is the general thumb rule for predicting the type of bond based upon the electronegativity differences:

- If the electronegativities are equal (i.e. the difference in **electronegativity difference is 0**), the bond is *non-polar covalent*.
- If the difference in electronegativities between the two atoms is **greater than 0, but less than 2.0**, the bond is *polar covalent*.
- If the difference in electronegativities between the two atoms is **2.0, or greater**, the bond is *ionic*.

HYDROGEN CHLORIDE	TETRACHLOROMETHANE	WATER
NET DIPOLE - POLAR	NON-POLAR	NET DIPOLE - POLAR

Notice here that, although individual C-Cl bonds in CCl_4 are polar, the whole molecule is non-polar because the four dipole cancel each other. The same for a molecule like $O=C=O$ where each C=O bond is polar but cancel each other in the molecule since they are directed in opposite directions.

Checking up 4.7

(a) Predict whether the following bonds in compounds are polar, non polar or ionic.

(i) BeCl_2 (ii) BF_3 (iii) CH_4 (iv) PCl_3 (v) H_2S (vi) SnCl_2
(vii) CO_2 (viii) SO_2 (ix) SO_3 (x) SF_6 (xi) PCl_5 (xii) Cl_2

(b) Some molecules above have polar bonds but overall the molecules are non polar. Identify the molecules and explain the statement.

(c) Explain how the nature of the bonds (polar, non polar or ionic) affect the physical properties of the different compounds. Use specific examples.

(d) Hydrogen chloride and ammonia are very soluble in water and yet they are covalent compounds. Explain

(e) Draw the shapes of the molecules above in (a) and predict whether the molecule is overall polar, or non polar.

4.8. Simple and giant covalent structures

Activity 4.8

1. With reference to CO_2 , C_4H_{10} , diamond and graphite explain how their sizes can affect their physical properties.
2. Diamond is said to be the hardest substance known. Explain this statement
3. Graphite is soft and can be used as a lubricant. Explain the statement.
4. Graphite conducts electricity while diamond does not. Explain.
5. Relate the physical properties of diamond and graphite to their uses

Covalent bonds involve the *sharing of electrons* so that all atoms have '**complete outer shells**'. Sometimes in a covalent bond, both shared electrons come from the same atom. This is known as a **Dative Covalent Bond**. This often results in the formation of charged molecules.

Covalently bonded substances fall into two main types:

- Simple molecular structures
- Giant covalent structures.

Giant structures are usually arranged into giant regular lattices and they are extremely strong because they have many bonds involved.

(a) *Simple molecular structures and their physical properties*

Simple molecules are those substances composed of relatively small covalently bonded structures and these contain only a few atoms held together by strong covalent bonds. An

example is carbon dioxide (CO₂), the molecule which contain one *atom* of carbon bonded with two atoms of oxygen,

Iodine which at room temperature and pressure. Iodine is a black- greyish solid. However it doesn't need to be warm much in order to produce a purple vapour. This is because iodine is composed of diatomic molecules (I₂) which exist in an ordered molecular crystal in the solid state. Each molecule is independent of the others, only being attracted by van der Waals' forces. Therefore, little energy is required to separate the iodine molecules.

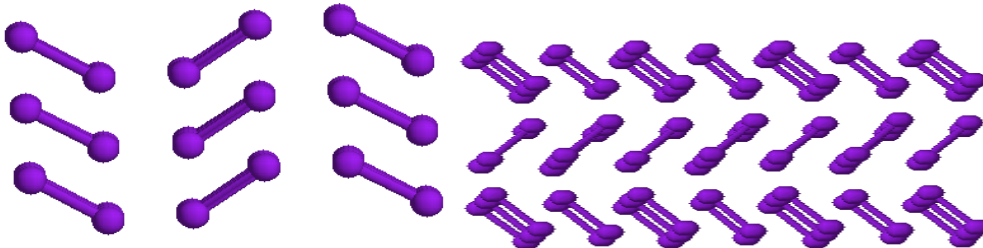

Simple molecular compounds display some physical properties as follows.

(i) Low melting and boiling points

Simple Molecular Structures tend to have low melting and boiling points since the forces between molecules (intermolecular forces, which are van der Waals forces) are quite weak. Little energy is required to separate the molecules.

e.g. of boiling points: CH₄: -161°C, C₂H₆: -88°C, C₃H₈: -42°C

(ii) Poor electrical conductivity: There are no charged particles (ions or electrons) delocalized throughout the molecular crystal lattice to conduct electricity. They cannot conduct electricity in either the solid or molten state.

(iii) Solubility: Simple structures tend to be quite insoluble in water, but this depends on how the polarized molecule is. The more polar the molecules, the more water molecules will be attracted to them (some may dissolve in water as a result of forming hydrogen bonds within it). Molecular crystals tend to dissolve in non-polar solvents such as alcohol.

(iv) Soft and low density: Van der Waals forces are weak and non-directional. The lattice is readily destroyed and the crystals are soft and have low density.

Molecular solids

(b) Giant covalent structures and their physical properties

Sometimes covalently bonded structures can form giant networks, known as **Giant Covalent Structures**. In these structures, each network of bonds connects all the atoms to each other.

These structures are **usually very hard and have high melting and boiling points**. This is because of the strong covalent bonds holding each atom in place. In general, Giant Covalent Structures **cannot conduct electricity** due to the fact that there are no free charge carriers. One **notable exception is Graphite**. This is a structure composed of 'sheets' of carbon atoms on top of each other. Electrons can move between the sheets and carry the electricity. The main giant covalent molecular structures are the two *allotropes* of carbon (*diamond* and *graphite*), and silica (*silicon dioxide*).

(i) Diamond structure and *the physical properties*

Diamond is a form of carbon in which each carbon atom is joined to four other carbon atoms, forming a giant covalent structure with four single bonds. As a result, diamond is very hard and has a high melting point. It does not conduct electricity. Diamond is tetrahedral face-centered cubic as shown in the figure below

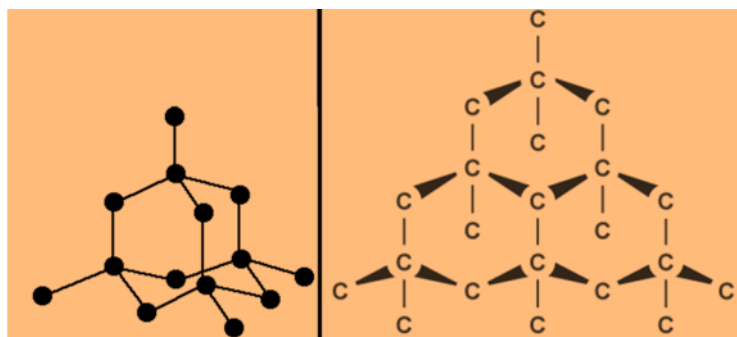

Figure 4.8: The structure of diamond

Diamond has a very high melting point (almost 4000°C): the carbon-carbon covalent bonds are very strong and have to be broken throughout the structure before melting occurs.

The compound is **very hard due to the necessity** to break very strong covalent bonds operating in 3-dimensions.

Diamond **does not conduct electricity**: All the electrons are held tightly between the atoms, and are not able to move freely.

The compound is **insoluble in water and other organic solvents due to** no possible attractions which could occur between solvent molecules and carbon atoms which could outweigh the attractions between the covalently bound carbon atoms.

(ii) Graphite and *the physical properties*

Graphite is another form of carbon in which the carbon atoms form layers. These layers can slide over each other and graphite is much softer than diamond. Each carbon atom in a layer is joined to only three other carbon atoms in hexagonal rings as shown in the figure below.

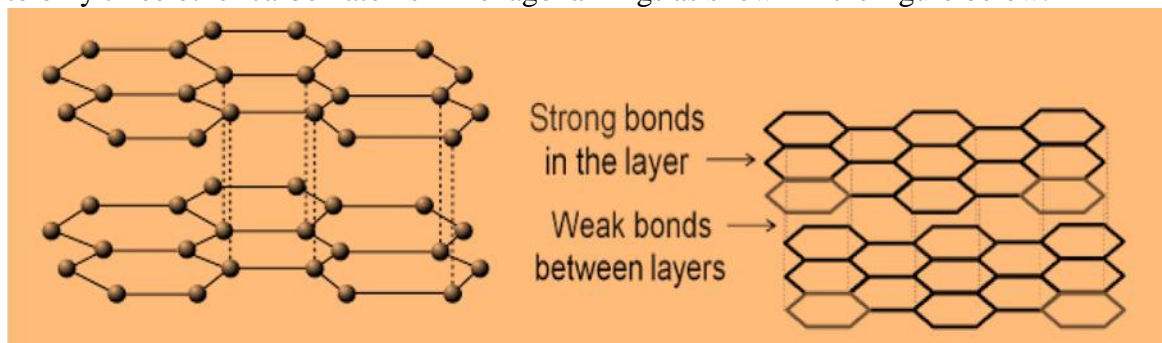

Figure 4.9: The structure of graphite

Concerning the properties of graphite:

- ***It has a high melting point, similar to that of diamond:*** In order to melt graphite, you have to break the covalent bonding throughout the whole structure.
- ***Graphite has a soft, slippery feel, and is used in pencils and as a dry lubricant for things like locks.*** You can think of graphite rather like a pack of cards - each card is strong, but the cards will slide over each other, or even fall off the pack altogether. When you use a pencil, sheets are rubbed off and stick to the paper.
- ***Graphite has a lower density than diamond*** because of the relatively large amount of space between the sheets.
- ***It is insoluble in water and organic solvents due to*** the same reason as that of diamond. The attractions between solvent molecules and carbon atoms will never be strong enough to overcome the strong covalent bonds in graphite.
- ***Graphite is a conductor of electricity*** due to the delocalized electrons which are free to move throughout the sheets. If a piece of graphite is connected into a circuit, electrons can fall off one end of the sheet and be replaced with new ones at the other end.

(iii) Silicon dioxide (SiO₂) and the physical properties

Silica, which is found in sand, has a similar structure to that of diamond. It is also hard and has a high melting point, but contains silicon and oxygen atoms, instead of carbon atoms. It is tetrahedral (Figure...). The fact that it is a semiconductor makes it immensely useful in the electronics industry: most transistors are made of silica.



Figure 4.10: The structure of silicon dioxide

Silicon dioxide exhibits some physical properties such as:

- ***It has a high melting point*** (around 1700°C) which varies depending on what the particular structure is (remember that the structure given is only one of three possible structures). Very strong The silicon-oxygen covalent bonds is very strong and have to be broken throughout the structure before the melting occurs.
- ***Silicon dioxide is hard*** due to the need to break the very strong covalent bonds.
- ***Silicon dioxide is not displaying the property of electrical conductivity because*** all the electrons are held tightly between the atoms, and are not able to move freely. ***No*** any delocalized electrons are observed.

- ***It is insoluble in water and organic solvents*** because no possible attractions occur between solvent molecules and the silicon or oxygen atoms which could overcome the covalent bonds in the giant structure.

Checking up 4.8

1. Diamond, graphite and silicon dioxide are all examples of giant covalent structures. What does the word giant mean in this context?
 - a) Draw a diagram to show the arrangement of carbon atoms in a diamond crystal.
 - b) Draw a diagram or diagrams to show the arrangement of carbon atoms in a graphite crystal.
2. Answer the following questions by referring to the diagrams you have drawn in question 2.
 - a) Explain why diamond is very hard, whereas graphite is so soft that it can be used in pencils or as a lubricant.
 - b) The densities of diamond and graphite are: diamond 3.51 g cm^{-3} ; graphite 2.25 g cm^{-3} . Explain why graphite is less dense than diamond.
 - c) Although graphite is very much softer than diamond, both substances have very high melting points. Explain why that is.
 - d) Explain why graphite conducts electricity whereas diamond doesn't.
 - e) Explain why neither material is soluble in water or any other solvent under normal conditions.
- 4.a) Draw a diagram to show the structure of silicon dioxide.
 - b) Explain why silicon dioxide
 - (i) is hard;
 - (ii) has a high melting point;
 - (iii) Doesn't conduct electricity;
 - (iv) is insoluble in water and other solvents.

4.9. Intermolecular Forces

Activity 4.9

1. Describe how the Van- der -waal's force arise.
 - (i) Trichloromethane (ii) ethanol (iii) aluminium fluoride. Arrange these compounds in order of increasing boiling points.

Intermolecular forces are electrostatic forces which may arise from the interaction between partial positively and negatively charged particles. Intermolecular forces exist between two molecules while intramolecular forces hold atoms of a molecule together in a molecule (Figure 4.11).

Intermolecular forces are *much weaker* than the intramolecular forces of attraction but are important because they determine the physical properties of molecules such as their boiling point, melting point, density, and enthalpies of fusion and vaporization.

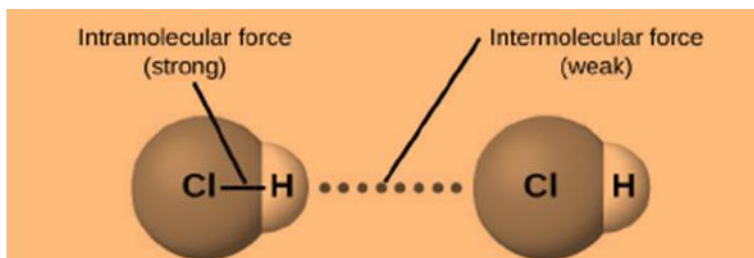

Figure 4.11: Intermolecular and intramolecular forces in a molecule

Intramolecular forces keep a molecule intact. Intermolecular forces hold multiple molecules together and determine many of a substance's properties.

All of the attractive forces between neutral atoms and molecules are known as **Van der Waals forces**, they are usually referred as intermolecular attraction.

We shall distinguish three kinds of intermolecular interactions such as London dispersion forces, dipole-dipole interactions and hydrogen bonding later in the unit

4.9.1. London dispersion forces

These are the weakest of the intermolecular forces and exist between *all types of molecules, whether ionic or covalent—polar or non-polar*. The more electrons a molecule has, the stronger the London dispersion forces are. For example, bromine, Br_2 , has more electrons than chlorine, Cl_2 , so bromine will have stronger London dispersion forces than chlorine, resulting in a higher boiling point for bromine, 59°C , compared to chlorine, -35°C . Also, the breaking of London dispersion forces does not require more energy, which explain why non-polar covalent compounds such as methane and nitrogen which only have London dispersion forces of attraction between the molecules freeze at very low temperatures.

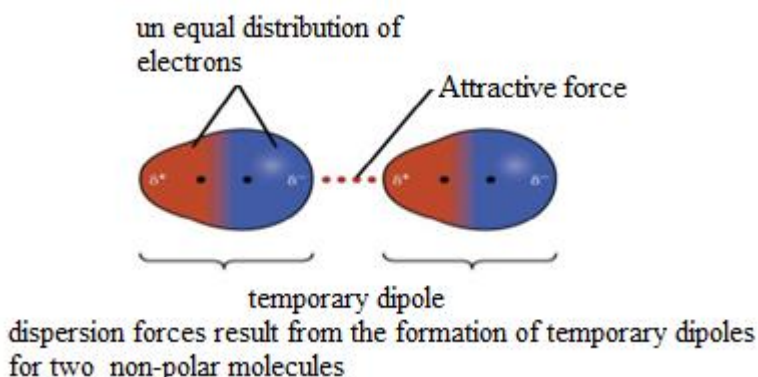

Figure 4.12: London dispersion forces

4.9.2. Dipole-dipole interaction

This kind of occurs between molecules containing polar bonds and acts in addition to the basic van der Waals' forces. The extra attraction between dipoles means that more energy must be added to separate molecules. The boiling points are higher than the expected for a given mass. The figure...below shows the dipole-dipole attraction between molecules of HCl.

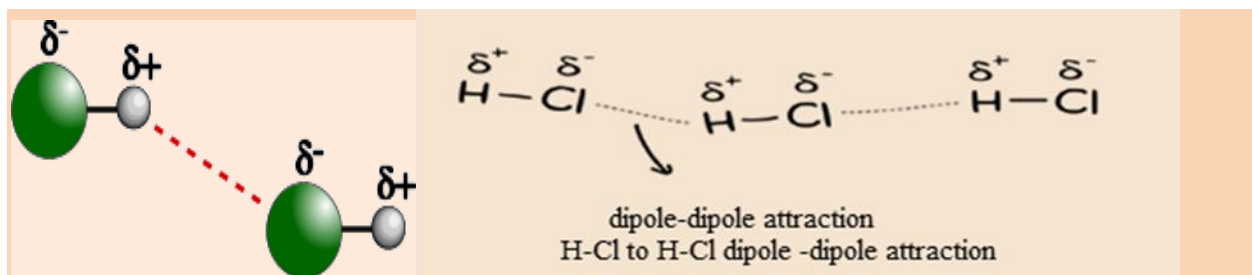

Figure 4.13: Dipole-dipole attraction

4.9.3. Hydrogen bond

For a hydrogen bond to be possible, there are necessary conditions:

- The first condition is that the molecule contains one group where hydrogen is bonded to one of the three most electronegative atoms (F, O, N), i.e. the presence of one or another of the following bonds: H-F, O-H, N-H,
- Because of high electronegativity of the 3 atoms, the bond they form with hydrogen is highly polar, with a partial positive charge on hydrogen atom and a partial negative charge of the other atom (see Fig.4.13, red arrows).
- When two molecules containing that group approach each other, they rearrange themselves so that $H^{\delta+}$ end on one molecule attracts for example the $F^{\delta-}$ end on the other molecule as shown in (Figure 4.13, broken line).
- It is this attraction force between the two molecules, the broken line that is called “Hydrogen bond”. Hydrogen bond is a Van der Waals force, but stronger than other Van der Waals forces and that is why it has been given a specific name.

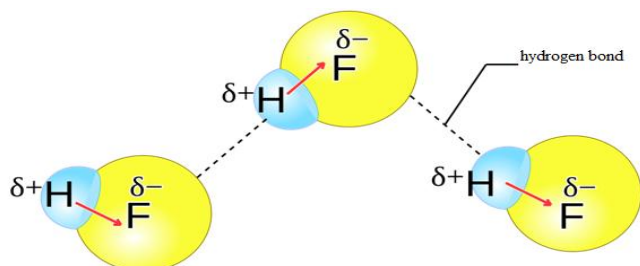
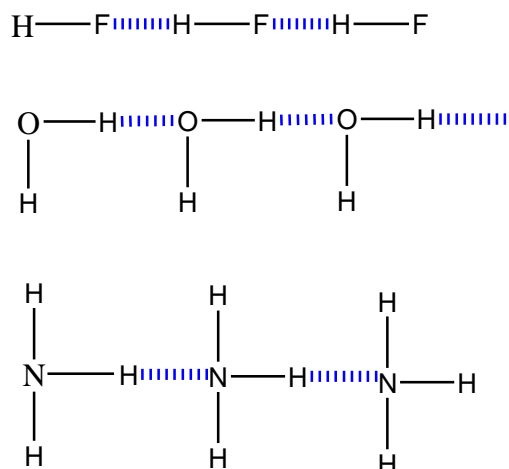

Figure 4.13: Representation of hydrogen bond in HF molecules

The bond energy of hydrogen bond is of the order of 20 kJmol^{-1} .

Example of Hydrogen bond in H_2O , HF, and NH_3 molecules



Consequences of the presence of hydrogen bond in a compound

Because of the presence in a compound of hydrogen bond, a strong force that requires more energy to overcome, this compound will possess higher melting and boiling points than the compounds of comparable molecular mass but without hydrogen bond.

This explain why water has abnormally high melting and boiling points compared to other hydrides of Group 16 elements (Fig.4.14).

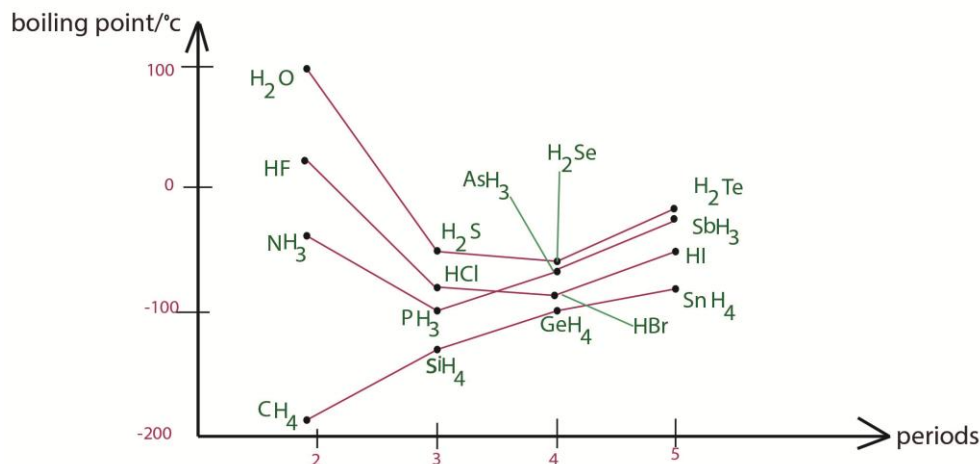
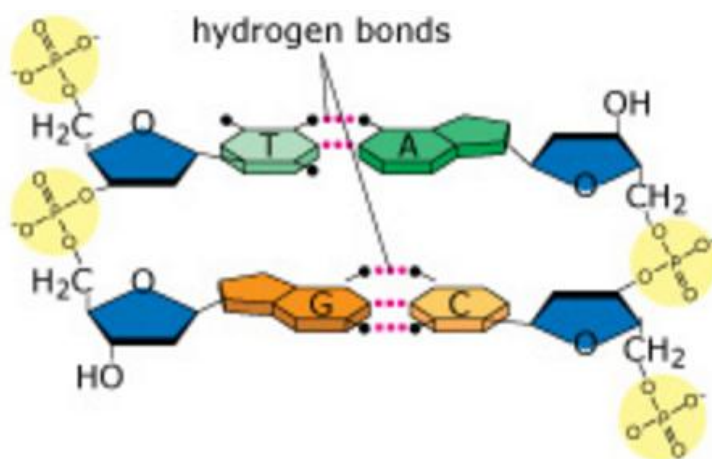

Figure 4.14: Boiling points of different hydrides

The presence of O-H and N-H groups in a compound makes that compound very soluble in water because of strong interactions between water molecules and the molecules of the solute containing such groups; e.g. alcohols, ammonia, amines, etc....

Hydrogen bond is responsible in maintaining the two chains of DNA together. It is found also in many other molecules of biological importance such as proteins.



Hydrogen bonds in DNA

(https://www.easynotescards.com/notecard_set/59549)

Hydrogen bonding in ice

Each water molecule is hydrogen-bonded to 4 others in a tetrahedral formation. The ice molecule has a “diamond-like” structure. When liquid water freezes, the hydrogen bonds become more rigid, and the volume becomes larger than the liquid because of empty space generated by the rigidity of solid water. This explains why ice floats over liquid water because its density is lower than the density of liquid water.



structure of molecules in water

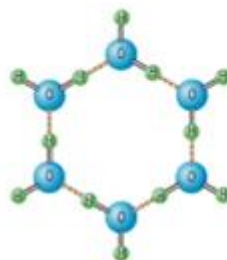

structure of molecules in ice

Figure 4.15: Structure of water and ice with hydrogen bond

This explains also why, if closed glass bottle full water is left in the fridge for long time, it will crack under the pressure of increasing volume of solid water, the ice.

Checking up 4.9

1. Ice floats in water and yet ice is in solid state. Explain the statement
2. The melting and boiling points of alcohols are much higher than the corresponding alkanes of almost the same molecular mass. Explain the statement.
3. Water boils at 100°C while H_2S boils at -64°C . Explain the statement.

4. Arrange the following compounds in order of increasing boiling points HCl, HBr and HI giving reasons.
5. Arrange the following compounds in the order of increasing boiling points. Explain your answer.
n- Pentane, 2-methylbutane and 2, 2-dimethylpropane has boiling points 36, 28, and 10°C respectively. Explain
6. (a) What is a hydrogen bond?
(b) Explain the origin of hydrogen bond in different molecules.

4.10. End unit assessment

PART 1: MULTIPLE CHOICE QUESTIONS

1. Which general trend on the periodic table shows a decrease in electronegativity?

A right to left, bottom to top **B** right to left, top to bottom **C** left to right, top to bottom **D** left to right, bottom to top

2. Which structure would sulphur (s), S₈, have?

A simple covalent molecules **B** simple covalent lattice **C** giant covalent lattice **D** giant ionic lattice

3. Which statement(s) is/are true?

- 1) Water has hydrogen bonds which increase the boiling point.
- 2) Water as a solid is more dense than as a liquid.
- 3) Water has bond angles of 180°.

A 1, 2 and 3 **B** only 1 and 2 **C** only 2 and 3 **D** only 1

4. Which molecules have the strongest intermolecular forces?

A BF₃ **B** H₂SC NH₃ **D** H₂

5. Which would have a permanent dipole?

A H₂O **B** CO₂ **C** NH₄⁺ **D** CH₄

6. What is the bond angle of a H₃O⁺ ion?

A 104.5° **B** 107° **C** 109.5° **D** 120°

7. Which is the correctly drawn ammonium ion?

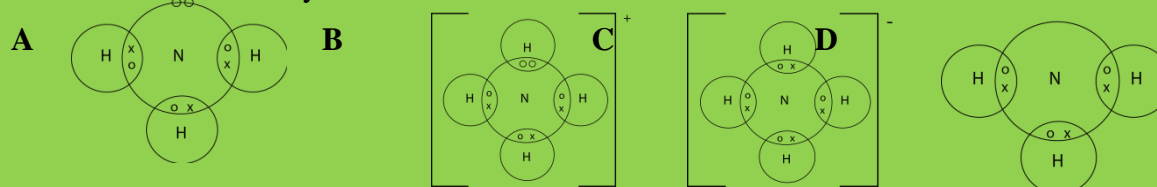

8. Which of the below is described by: high melting point, can conduct, soluble in water.

A Al(s) **B** carbon (graphite) **C** CH₄(g) **D** NaCl(aq)

9. Molecule with bond of shape trigonal pyramid is

A H₂O **B** CO₂ **C** NH₃ **D** BF₃

10. Which of the following statements is false about VSEPR theory?

a) The geometry of a molecule is determined by the number of electron groups on the central atom.

b) The geometry of the electron groups is determined by minimizing repulsions between them.

c) a lone pair, a single bond, a double bond, a triple bond and a single electron - each of these is counted as a single electron group.

d) Bond angles may depart from the idealized angles because lone pairs of electrons take up less space than bond pairs.

e) The number of electron groups can be determined from the Lewis structure of the molecule.

11. Bond angle of SF₆ is

A 90° **B** 180° **C** 120° **D** 87.5°

12. Lone pairs in CO₂ are

A 1 **B** 2 **C** 3 **D** 4

13. Number of bonding pairs of electrons in water H₂O is

A 1 **B** 2 **C** 3 **D** 4

14. Molecular structure of SF₆ is

A linear **B** tetrahedral **C** hexagonal **D** octahedral

15. Which of the following pairs of substances have the same shape?

A. CO₂ and SiO₂ **B** BCl₃ and PCl₃

C. BeH₂ and H₂S **C.** CH₄ and AlCl₄⁻

PART 2: Filling in questions

16. Use the words listed below to fill in the correct appropriate word(s) in the spaces below in the text.

Bigger covalent bond diamond free electrons halogens hard crystals high electrical conductivity high melting points increase intermolecular forces low electrical conductivity low melting points non-metals sharing soft crystals strong strong bond weak weak force.

A is formed by two atoms..... one or more pairs of electrons to make abetween the two atoms in a molecule. However, between small molecules, only aholds them together in the bulk liquid or solid. This results in small covalent molecules having andif solid. Small covalent molecules have no and so have a The Group 7 collectively known as the.....form diatomic molecules of two atoms. Thebetween the molecules are giving them relatively low melting points and boiling points. This also explains why they are gases, liquids or solids with As you go down Group 7 the melting boiling points and boiling pointsbecause the molecules get and the intermolecular forces In giant covalent structures the forces between all the atoms areforming like diamond or silica . In the atomic giant structure metals there are free electrons which allow

PART3:

17. Fill in the table by putting a check mark in the compare-and-contrast matrix under the column(s) that each physical attribute describes.

Physical Attribute	Covalent Compound	Ionic Compound	Metal
a. Usually gases or liquids at room temperature			
b. Usually a solid or solid crystals at room temperature			
c. Low melting and boiling points			
d. High melting and boiling points			
e. Dissolves easily in water			
f. Poor conductor of electricity in any form			
g. Good conductor of heat and electricity			

PART4: SHORT AND LONG ANSWER QUESTIONS

18. (a) what is a covalent bond and how does it differ from ionic and metallic bonds.
(b) Using dot and cross diagrams show how bonding takes place in carbon dioxide (CO₂) and methane (CH₄).

(c) Compare the bond length between C-O in carbon dioxide and C-H in methane and explain.

19. The proton numbers of X, Y, and Z are 12, 7 and 17 respectively.

(a) Write the electronic configuration of X, Y, and Z.

(b) Give the formula of the compound formed between Y and Z and draw its Lewis structure

20. Under high pressure hydrogen is a conductor of electricity. Explain the observation.

During this process the hydrogen-hydrogen bonds will break and the molecules will fall apart into hydrogen atoms. It is believed the electrons in this solid will flow freely; meaning atomic hydrogen should behave like a metal and conduct electricity

21. X is a hard solid at room temperature .X does not conduct electricity in the solid state or when molten. Describe the type of bonding in X

22. All the sulphur-oxygen bonds in the SO₄²⁻ ions are exactly identical. Explain the observation.

23.

Substance	Formula	Relative molecular mass	Melting point/ ^o C
neon	Ne	20	-248
Argon	Ar	40	-189
Water	H ₂ O	18	0
Sodium chloride	NaCl	58.6	800
Diamond	C	12	3550

Explain the trend of the melting point of the above substances in relation to their structure and bonding.

24. Nitrogen and phosphorus are in the same group in the periodic table. Nitrogen can form the NCl₃ molecule only, but phosphorus can form both the PCl₃ and PCl₅ molecule.

(a) Write the electronic configuration of the nitrogen and phosphorus atoms.

(b) Draw the Lewis diagram for the NCl_3 and PCl_3 and predict their shapes.

(c) based on your answer in (a) and (b), explain why phosphorus can form the PCl_5 molecule but nitrogen cannot form NCl_5 molecule.

25(a) with the aid of suitable diagrams, explain the bond formation process in: (i) AlCl_3 and (ii) Al_2Cl_6

(b) Using the hybridization theory, explain the formation of the CH_3Cl molecule.

(c) Predict the shape of the following molecules, and state whether they are polar or non-polar

(i) NCl_3 (ii) BCl_3 (iii) CO_2

(d) Carbon and silicon are in group (iv) of the periodic table. Both react with oxygen to form their respective dioxides. Carbon dioxide is a gas at room conditions but silicon dioxide is a hard solid. Explain their differences in terms of bonding and structure.

26. The proton number of sulphur is 16.

(a) Write the electronic configuration of sulphur in the ground state using s,p,d... notation.

(b) Under suitable conditions, sulphur reacts with chlorine to form SCl_2 .

(i) Draw the Lewis structure of SCl_2

(ii) Predict the shape of SCl_2

27. For the following **covalently** bonded molecules please fill in the following missing information in the chart. Follow the directions below!

a) In the space that says “show work here” you must show your work to show how the electrons will be bonded.

b) Write the structural formula in the next column being sure to include unshared electrons

c) Write the name of the shape in the “Geometry name” column (ex: linear)

d) Write whether the molecule is polar or non-polar by writing it in that column

Molecule	Structural Formula	Geometry name	Polar/ Nonpolar
CF_2Br_2			
SbCl_5			
P_2			
CH_2Se			

PART4: MATCHING TYPE QUESTIONS

28. Please match the term with the correct definition. There will be extra choices and some choices may be used more than once.

A. Electronegativity B. Covalent bonding C. Ductile D. Aqueous E. Tetrahedral

F. Molecular Formula G. Linear H. Non-polar I. Solid J. Trigonalbipyramidal K. Crystal

L. Pyramid M. Polar N. VSEPR O. Malleable P. Octet Rule

Q. Ionic bonding R. Empirical Formula

A 3-D, repeating pattern of + and – ions, formed by ionic compound

Tendency for an atom to attract electrons when chemically bonded to another atom

A sharing of electrons

Atoms will gain or lose enough electrons in order to become isoelectronic with a noble gas

A transfer of electrons

A chemical formula that is arranged in the smallest whole number ratio

The term that means dissolved in water

A chemical formula that describes the makeup of a single molecule

The shape (geometry) that is always an exception to the octet rule

A bond where electrons are shared unequally between atoms

One of the shapes (geometries) that will always be polar

A bond where electrons are shared equally between atoms

29. Use the given information to complete the crossword puzzle below

Across

11. A covalent bond between atoms in which the electrons are shared unequally

12. A covalent bond in which the electrons are shared equally by the two atoms

14. Intermolecular forces resulting from the attraction of oppositely charged regions of polar molecules

15. A bond formed when two atoms share a pair of electrons

16. The two weakest intermolecular attractions - dispersion interactions and dipole forces

18. A covalent bond in which one atom contributes both bonding electrons

20. A chemical formula that shows the arrangement of atoms in a molecule or polyatomic ion

21. A covalent bond in which three pairs of electrons are shared by two atoms

22. A bond in **which** two atoms share two pairs of electrons

23. A compound that is composed of molecules

26. A molecule consisting of two atoms

28. One of the two or more equally valid electron dot structures of a molecule or polyatomic ion

31. valence-shell electron-pair repulsion theory; because electron pairs repel, molecules adjust their shapes so that valence electron pairs are as far apart as possible

Down

1. An orbital that applies to the entire molecule

2. A bond angle of 109.5 degrees that results when a central atom forms four bonds directed toward the center of a regular tetrahedron

3. The mixing of several atomic orbitals to form the same total number of equivalent hybrid orbitals

4. A tightly bound group of atoms that behaves as a unit and has a positive or negative charge

5. A pair of valence electrons that is not shared between atoms

6. A molecule in which one side of the molecule is slightly negative and the opposite side is slightly positive.

7. a covalent bond in which the bonding electrons are most likely to be found in sausage-shaped regions above and below the bond axis of the bonded atoms

8. A covalent bond between atoms in which the electrons are shared unequally

9. A neutral group of atoms joined together by covalent bonds

10. A molecule that has two poles, or regions, with opposite charges

12. The energy required to break the bond between two covalently bonded atoms
17. A chemical formula of a molecular compound that shows the kinds and numbers of atoms present in a molecule of a compound
19. Attractions between molecules caused by the electron motion on one molecule affecting the electron motion on the other through electrical forces
24. Attractive forces in which hydrogen covalently bonded to a very electronegative atom is also weakly bonded to an unshared electron pair of another electronegative atom
25. A solid in which all of the atoms are covalently bonded to each other
27. A molecular orbital that can be occupied by two electrons of a covalent bond
29. A bond formed by the sharing of electrons between atoms
30. A bond formed when two atomic orbitals combine and form a molecular orbital that is symmetrical around the axis connecting the two atomic nuclei

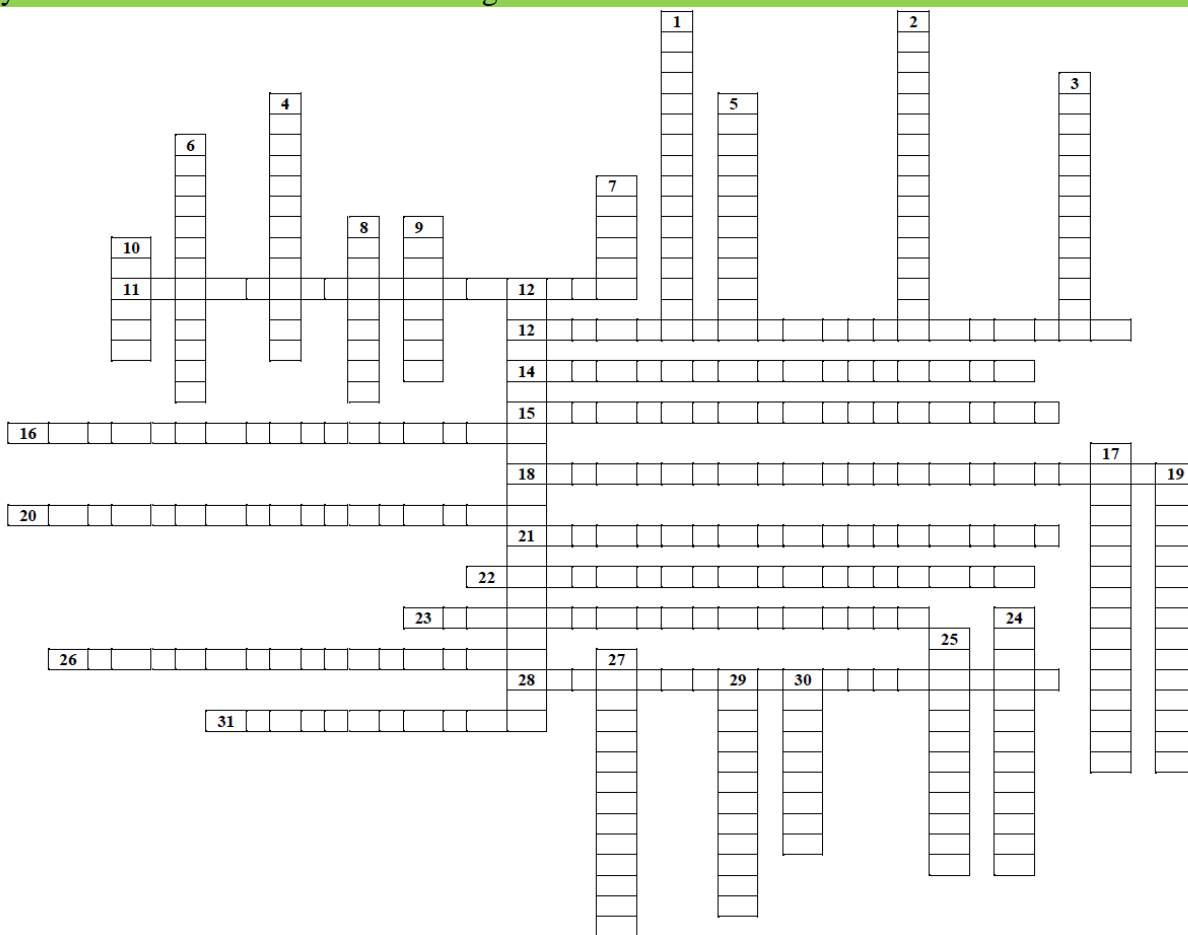

UNIT 5: VARIATION IN TRENDS OF THE PHYSICAL PROPERTIES

Key unit competency

Use atomic structure and electronic configuration to explain the trends in the physical properties of elements.

Learning objectives

By the end of this unit, I will be able to:

- Outline the historical background of the Periodic Table.
- Explain the trends in the physical properties of the elements across a period and down a group.
- Classify the elements into respective groups and periods using electronic configuration.
- Relate trends in physical properties of the elements to their electronic configuration.
- Classify the elements into blocks (s, p, d, f-block).

Introductory activity

By citing the example of a library having thousands of different books, the teacher led the students to the importance of classification.

Discuss:

1. Explain how elements can be classified into a periodic table?
2. Explain on which basis elements can be classified?
3. How many groups and periods comprises a modern periodic table?
4. How does electronic configuration of elements influence the structure of modern periodic table?
5. Discuss the basis of the location of the elements in the periodic table.

5.1. Historical Background of the Periodic Table

Activity 5.1

1. Who is the father of the periodic table? Explain your answers.
2. Differentiate the laws of triads and octaves

During the nineteenth century, many scientists contributed to the development of the periodic table. In the beginning, a necessary prerequisite to the construction of the periodic table was the discovery of the individual elements. Although elements such as gold, silver, tin, copper, lead and mercury have been known since antiquity, the first scientific discovery of an element occurred in 1649 when Hennig Brand discovered phosphorous. The periodic table of elements is a chart created in order to help to organize the elements that had been discovered at that time. By 1869, a total of 63 elements had been discovered. As the number of known elements grew, scientists began to recognize patterns in properties and began to develop classification schemes. Some important dates help us to understand more about how the periodic table has been created.

5.1.1. Law of Triads

In 1817 Johann Dobereiner noticed that the atomic weight of strontium fell midway between the weights of calcium and barium, elements possessing similar chemical properties.

In 1829, after discovering the halogen triad (three) composed of chlorine, bromine, and iodine and the alkali metal triad of lithium, sodium and potassium he proposed that nature contained triads of elements the middle element had properties that were an average of the other two members when ordered by the atomic weight (the **Law of Triads**).

Between 1829 and 1858 a number of scientists (Jean Baptiste Dumas, Leopold Gmelin, Ernst Lenssen, Max von Pettenkofer, and J.P. Cooke) found that these types of chemical relationships extended beyond the triad. During this time fluorine was added to the halogen group; oxygen, sulfur, selenium and tellurium were grouped into a family while nitrogen, phosphorus, arsenic, antimony, and bismuth were classified as another. Unfortunately, research in this area was hindered by the fact that accurate values were not always available.

5.1.2. Law of Octaves

In 1863, John Newlands, an English chemist suggested that elements be arranged in “octaves”. He wrote a paper in which classified the 56 established elements into 11 groups based on similar physical properties, noting that many pairs of similar elements existed which differed by some multiple of eight in atomic weight. This law stated that any given element will exhibit analogous behavior to the eighth element following it in the table. However, his law of octaves failed beyond the element calcium.

- ❖ In **1669**, **Hennig Brand** a German merchant and amateur alchemist invented the *Philosopher’s Stone*; an object that supposedly could turn metals into pure gold. He heated residues from boiled urine, and a liquid dropped out and burst into flames. He also discovered phosphorus.
- ❖ In **1680** **Robert Boyle** also discovered *phosphorus* without knowing about Henning Brand’ discovery.
- ❖ In **1809**, curiously **47 elements** were discovered and named, and scientists began to design their atomic structures based on their characteristics.
- ❖ In **1869**, **Dimitri Mendeleev** based on John Newlands’ ideas started the development of elements organized into the periodic table. The arrangement of chemical elements were done by using atomic mass as the key characteristic to decide where each element belonged in his table. The elements were arranged in rows and columns. He predicted the discovery of other elements, and left spaces open in his periodic table for them.
At the same time, Lothar Meyer published his own periodic table with elements organized by increasing atomic mass.
- ❖ In **1886**, French physicist **Antoine Becquerel** first discovered *radioactivity*. **During the same period of 1886**, **Ernest Rutherford** named *three types of radiation*; alpha, beta and gamma rays.
- ❖ In **1886**, **Marie** and **Pierre Curie** started working on the *radioactivity and they discovered* radium and polonium. They discovered that beta particles were negatively charged.

- ❖ In **1895**, **Lord Rayleigh** discovered a new gaseous element named argon which proved to be chemically inert. This element did not fit any of the known periodic groups.
- ❖ In 1898, **William Ramsay** suggested that argon be placed into the periodic table between chlorine and potassium in a family with helium, despite the fact that argon's atomic weight was greater than that of potassium. This group was termed the "zero" group due to the zero valency of the elements. Ramsey accurately predicted the future discovery and properties neon.
- ❖ In 1913, Henry Moseley worked on X-rays and determined the actual nuclear charge (atomic number) of the elements. He has rearranged the elements in order of increasing atomic number.
- ❖ In **1897** English physicist **J. J. Thomson** discovered small negatively charged particles in an atom and named them as *electrons*; **John Sealy Townsend** and **Robert A. Millikan** investigated the electrons and determined their *exact charge and mass*.
- ❖ In **1900**, **Antoine Becquerel** discovered that *electrons and beta particles* as identified by the Curies are the *same thing*.
- ❖ In **1903**, **Ernest Rutherford** proclaimed that *radioactivity is initiated by the atoms which are broken down*.
- ❖ In **1911**, **Ernest Rutherford** and **Hans Geiger** discovered that electrons are moving around the nucleus of an atom.
- ❖ In **1913**, **Niels Bohr** discovered that *electrons move around a nucleus in discrete energy called orbits*. He observed also that Radiation is emitted during movement from one orbital to another.
- ❖ In **1914**, **Rutherford** identified *protons* in the atomic nucleus. He also transformed *a nitrogen atom into an oxygen atom for the first time*. English physicist **Henry Moseley** provided *atomic numbers*, based on the number of electrons in an atom, rather than based on atomic mass.
- ❖ In **1932** **James Chadwick** discovered *neutrons*, and *isotopes* were identified. This was the complete basis for the periodic table. In that same year Englishman **Cockroft** and the Irishman **Walton** first *split an atom by bombarding lithium in a particle accelerator*, changing it to two helium nuclei. The last major changes to the periodic table give rise from Glenn Seaborg's work in the middle of the 20th Century. In 1940, he discovered plutonium and all the transuranic elements from 94 to 102.
- ❖ In 1944, Glenn T. Seaborg discovered 10 new elements and moved out 14 elements of the main body of the periodic table to their current location below the lanthanide series. These elements were known as Actinides series.

In 1951, Seaborg was awarded the Nobel Prize in chemistry for his work. Element 106 has been named seaborgium (Sg) in his honor.

- ❖ Presently, 118 elements were placed in the modern Periodic Table.

Although Dmitri Mendeleev is often considered the "father" of the periodic table, however the work of many scientists contributed to its present form. The representation of a modern Periodic Table of Elements is shown below.

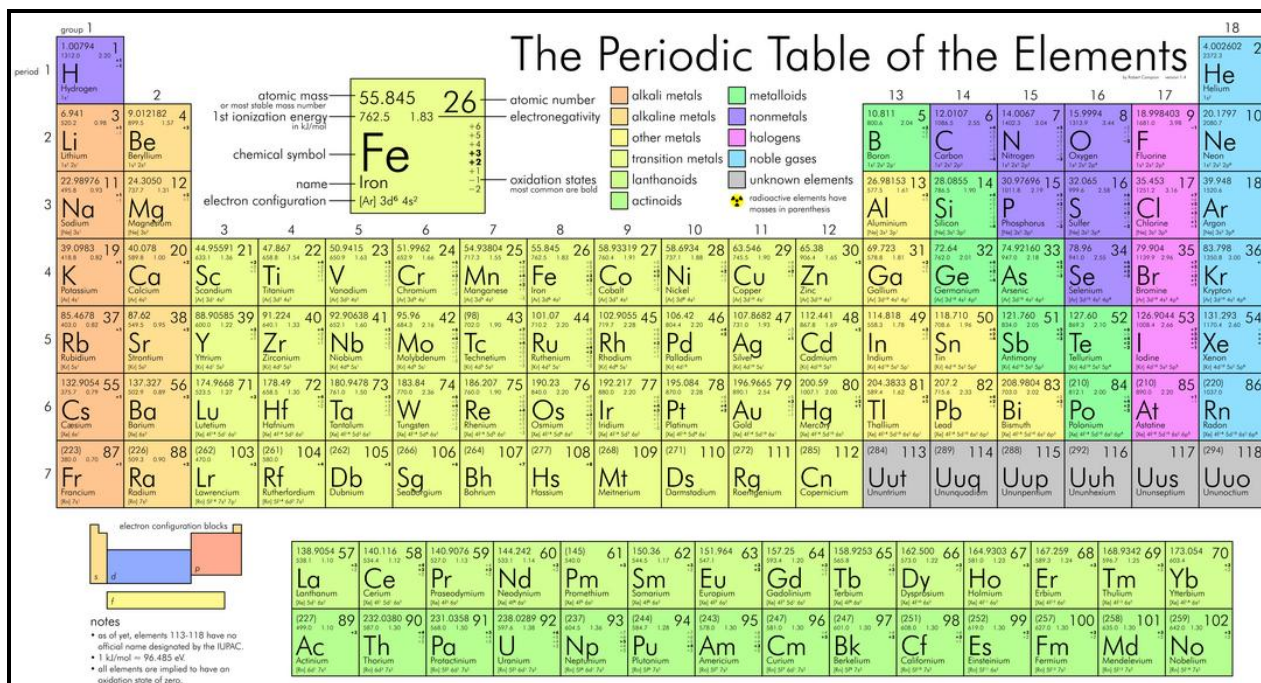

Figure 5.1: The periodic table of elements

Checking up 5.1

A periodic table is an important tool used in chemistry:

1. Explain why the elements are classified in groups and periods of the periodic table
2. Chose one elements of Group 1 and one of group 17 and make their electronic configurations using orbitals.

5.2. Comparison of Mendeleev’s Table and Modern Periodic Table

Activity 5.2

1. Discuss the similarities and differences of Mendeleev’s table and modern periodic Table.
2. How were the positions of cobalt and nickel resolved in the modern periodic table?

The periodic table is the arrangement of chemical elements according to their chemical and physical properties. The modern periodic table was created after a series of different versions of the periodic table. The Russian Chemist/Professor Dmitri Mendeleev was the first to come up with a structure for the periodic table with columns and rows. This feature is the main building block for the modern periodic table as well. The columns in the periodic table are called *groups*, and they group together elements with similar properties. The rows in the periodic table are called *periods*, and they represent sets of elements that get repeated due the possession of similar properties. The **main difference** between Mendeleev and Modern Periodic Table are shown in the Table below (Table 5.1).

Table 5.1. Differences between Mendeleev's table and the modern Periodic Table

Mendeleev's table	Modern Periodic Table
Mendeleev's periodic table was created on the basis of periodic functions of the elements, leaving room for future findings of the missing elements at that time.	The modern periodic table is the one used at the moment, as a collective improvement of the works of so many chemists and scientists in an effort to order the chemical elements according to the similarities in their properties.
Elements are ordered based on their increasing of atomic masses	Elements are arranged in increasing of their atomic numbers
There were no separate positions for isotopes of an element as their atomic masses were different	Separate positions of isotopes were not required as the elements have the same atomic numbers
Mendeleev's periodic table contains about 66 elements.	Modern periodic table contains 118 elements. More elements have been discovered since Mendeleev's time.
In Mendeleev's periodic table there were gaps for undiscovered elements.	Modern periodic table maintains uniformity.
In Mendeleev's periodic table noble gases were not placed (as they were not discovered at that time)	In Modern periodic table noble gases are put in a separate group named as group-18
In Mendeleev's periodic table transition elements were included with other elements	In Modern periodic table transition elements are placed in a separate block
The gaps in Mendeleev's have been filled by the elements that have been discovered	There are no gaps
Mendeleev arranged his periodic table in descending columns	Modern periodic table is arranged in rows called periods and columns called groups
Mendeleev's periodic table has 8 vertical columns called groups and 12 horizontal rows called periods.	Modern periodic table has 18 columns called groups and 7 rows called periods.
Mendeleev's periodic table has elements with dissimilar properties in the same group sometimes.	Modern periodic table's elements have similar properties repeated at regular intervals.
Mendeleev's table does not refer to the concept of the atomic structure.	Modern periodic table uses the atomic number by grouping the elements in such a manner that their electronic configuration can

	be deduced easily.
--	--------------------

Checking up 5.2

The periodic table is an arrangement of elements based on their properties.

1. Explain the gaps found in the Mendeleev periodic table compared to the modern one?
2. How many elements does the modern periodic table contain?
3. Look at the modern periodic table and write down four things it tells you.

5.3. Location of Elements in the Periodic Table Based On the Electronic Configuration

Activity 5.3

1. Based on knowledge gained in the previous years:
 - a. Represent the electronic configuration of the elements ^{25}X and ^{11}Y .
 - b. Discuss the information of the last orbitals of the above element informs you about the periodic table?
 - c. Explain the period and the group of the periodic table in which the above elements are located.
2. Is it possible to have an element with atomic number 1.5 between hydrogen and helium?

5.3.1. Major Divisions of the Periodic Table

The periodic table is a tabular of the chemical elements organized on the basis of their atomic numbers, electron configurations, and chemical properties.

In the periodic table, the elements are ordered by periods and groups. The period relates to the principal energy level. Elements with the same number of valence electrons are kept together in groups, such as the halogens and the noble gases. The chemical properties of an atom relate directly to the number of valence electrons, and the periodic table is a road map among those properties such that chemical properties can be deduced by the position of an element on the table. The electrons in the outermost or valence shell are especially important because they participate in forming chemical bonds.

Elements are presented in increasing atomic number. The main body of the table is a 18×7 grid. There are four distinct rectangular areas or blocks such as s, p, d and f blocks. The f-block is usually not included in the main table, but rather is floated below, as an inline f-block would often make the table impractically wide. Using periodic trends, the periodic table can help predict the properties of various elements and the relations between properties. It therefore provides a useful framework for analyzing chemical behavior and is widely used in chemistry and other sciences (Petrucci et al., 2007).

5.3.2. Location of elements in modern Periodic Table using examples

In the periodic table, the elements are located based on groups and periods.

a) Finding Period of elements

The Period of an element is equal to the highest energy level of electrons or principal quantum number. For a better understanding the following is an example:

Consider the element ${}_{16}\text{S}$ with the electronic configuration: $1s^2 2s^2 2p^6 \underline{3s^2 3p^4}$, the value 3 is the highest energy level of electrons or principal quantum number. Thus the period of S is 3.

If we consider another example, the electronic configuration of ${}^{23}\text{Cr}$ is: $1s^2 2s^2 2p^6 3s^2 3p^6 \underline{4s^2 3d^4}$. The value 4 is the highest energy level of electrons or principal quantum number. Thus the period of Cr is 4.

b) Finding Group of elements

The Group of an element is equal to the number of outermost or valence electrons of element or number of electrons in the highest energy level of elements. Another way of finding group of element is looking at sub shells. If the last sub shell of electron configuration is "s" or "p", then the group becomes "1 to 18" with the number of group corresponding to the electrons occupying the last orbitals according to the given examples.

Consider the element ${}^{19}\text{K}$ with the electronic configuration: $1s^2 2s^2 2p^6 3s^2 3p^6 \underline{4s^1}$. Since the last sub shell is "s" with one electron, the element K is located in group 1 of the periodic table.

Similarly, the element ${}^{35}\text{Br}$ has the corresponding electronic configuration: $1s^2 2s^2 2p^6 3s^2 3p^6 4s^2 3d^{10} \underline{4p^5}$. Since the last sub shell is "p", the element bromine (Br) is located in group 17 of the modern periodic table.

The elements of groups 3 to 12 have the electron configuration **ns** and **(n-1)d**, total number of electrons in these orbitals. This informs us that those elements are located in group of element corresponding to transition metals.

Let us consider the following examples.

The element ${}_{26}\text{Fe}$ has the **electronic configuration:** $1s^2 2s^2 2p^6 3s^2 3p^6 \underline{4s^2 3d^6}$, $6+2 = 8$ correspond to the group 8 of the transition elements.

Here are some evidences for everyone to find group number of elements.

Last Orbital Group: Considering the last orbital of an element, we are able to identify in which group of the periodic table it is located. The following tables showed the location of representative elements in different groups (Table 5.2) and transition elements (Table 5.3) based on the last orbital.

Table 5.2. Location of representative elements in groups

Last orbital	ns^1	ns^2	$ns^2 np^1$	$ns^2 np^2$	$ns^2 np^3$	$ns^2 np^4$	$ns^2 np^5$	$ns^2 np^6$
Group	1	2	13	14	15	16	17	18

Table 5.3. Location of transition elements in group A

Last orbital	$ns^2(n-1)d^1$	$ns^2(n-1)d^2$	$ns^2(n-1)d^3$	$ns^2(n-1)d^8$	$ns^2(n-1)d^5$	$ns^2(n-1)d^{10}$	$ns^2(n-1)d^9$ or $ns^1(n-1)d^{10}$
Group	3	4	5	8	7	12	11

Example: Find the period and the group of the elements $_{16}\text{X}$ and $_{24}\text{X}$ using its electronic configuration:

$_{16}\text{X}$: $1s^2 2s^2 2p^6 3s^2 3p^4$; the period of X is 3 and its group is 16

$_{24}\text{X}$: $1s^2 2s^2 2p^6 3s^2 3p^6 4s^2 3d^4$; the period is 4 and the group is $4 + 2 = 6$

The elements in the periodic table are also located using atomic orbitals.

5.3.3. Location of elements in the periodic table based on atomic orbitals

The properties of an atom depend eventually on the number of electrons in the various orbitals, and on the nuclear charge which determines the compactness of the orbitals. In order to relate the properties of the elements to their locations in the periodic table, it is often convenient to make use of a simplified view of the atom in which the nucleus is surrounded by one or more concentric spherical “shells,” which consists of the highest-principal quantum number. The shell model, as with any scientific model, is less a description of the world than a simplified way of looking at it that helps us to understand and correlate diverse phenomena.

We will look at several visualizations of the periodic table. First, however, it would be instructive to see how it is constructed from a logical viewpoint. The table today is the result of an ongoing effort of more than 100 years of observation, measurement, prediction and proof of the relationships of chemical and physical phenomena to electron configurations and charges.

Checking up 5.3

1. The elements X, Y, Z, T and U are given in the picture below.

X																			

Which one(s) of the following statements are correct, which one(s) are false for these elements.

- X is alkaline metal
- Y is in p block
- Z is halogens
- U is lanthanide
- T is noble gas

2. Explain the major parts of the periodic table?

3. Differentiate the blocks included in a periodic table?

- a. By using examples, locate at least two elements in each block
- b. Indicate the group and the period of the chosen element.

5.4. Classification of Elements into Blocks (s, p, d, f-block)

Activity 5.4.

1. Apart of blocks, the elements in the periodic table are classified as representative elements, transition metals, lanthanides and actinides. Match these categories with s, p, d and f-blocks of the periodic table.
2. Classify the following elements into s, p, d or f-block and justify your answer: Al (z=13), K (z= 19), Ca (z =20) and Fe (z=26).

In the Periodic Table, the elements are organized into different blocks according to their electron configurations. They are classified into four blocks such as s-block, p-block, d-block and f-block depending on the type of atomic orbitals that are being filled with electrons. This division is based upon the name of the orbitals which receives the last electron. The s-block contains two groups (reactive metals of Group 1 and 2; p-block is composed of *metals* and *nonmetals* of Group 13 to 18, d-block contains transition metals (Group 3 to Group 12) and f-block contains *lanthanide* and *actinide series* or *inner transition metals*. The division of elements into blocks is primarily based upon their electronic configuration as shown in Figure 5.1. Two exceptions to this categorization can be mentioned. Helium is placed in p-block although its valence electrons are in s orbital because it has a completely filled valence shell ($1s^2$) and as a result, displays properties representative of other noble gases. The other exception is hydrogen. It has only one s-electron and hence can be placed in group 1 (alkali metals); but in many modern Periodic Tables, hydrogen is left hanging above the Periodic Table and doesn't belong to any group. This is due to the particular properties of hydrogen:

- ✓ Hydrogen is a gas while the other elements of group 1 are solids,
- ✓ hydrogen is not a metal whereas the other elements of group 1 are metals,
- ✓ in some compounds where hydrogen combine with non-metals, it behaves like a metal, e.g. in the polar molecule $H^{\delta+}Cl^{\delta-}$, hydrogen tends to lose an electron,
- ✓ when combined with very active metals, it behaves as a non-metal and forms a negative ion H^- , hydride ion; e.g. Na^+H^- (sodium hydride).

Elements within the same group have the same number of electrons in their valence (outermost) shells, and they have similar electron configurations. They exhibit similar chemical properties. Elements within the same period have different number of electrons in their valence shells (the number is increasing from left to right) and different valence shell electron configuration. Therefore, elements in the same period are chemically different, changing from metals to non-metals across the period from left to right.

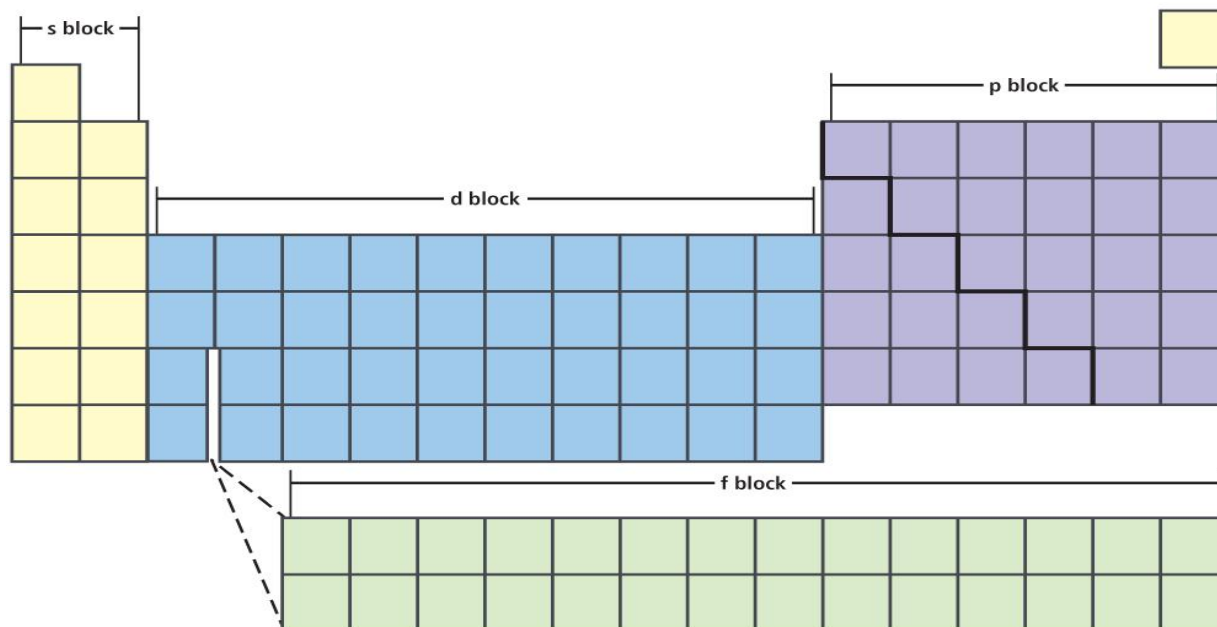

Figure 5.1: Division of the periodic table into s, p, d and f blocks.

5.5. Characteristics of different blocks of the periodic table

a) The s-block elements

The s-block comprises elements of Group 1 (alkali metals) and Group 2 (alkaline earth metals) which have ns^1 and ns^2 outermost electronic configuration. The elements of group 1 and 2 are classified as reactive metals with low ionization enthalpies and highly electropositive. They lose their valence electron(s) willingly to form a positive ion with the charge +1 in the case of alkali metals or +2 in the case of alkaline earth metals. The metallic character and reactivity of s-block elements increases as we move down the group. Because of high reactivity they are never found pure in nature. Most of the metals of this block convey characteristic colour to flame. They are soft metals with low melting and boiling points. The compounds of s-block elements, with the exception of those of lithium and beryllium are predominantly ionic. There are 14 s-block elements in the periodic table. The Table 5.4 below shows an example of the electronic configuration of some elements of Group 1.

Table 5.4. Electronic configuration for the group 1 elements

Period 1	Hydrogen (H)	$1s^1$	$1s^1$
Period 2	Lithium (Li)	$1s^2 2s^1$	$[\text{He}] 2s^1$
Period 3	Sodium (Na)	$1s^2 2s^2 2p^6 3s^1$	$[\text{Ne}] 3s^1$
Period 4	Potassium (K)	$1s^2 2s^2 2p^6 3s^2 3p^6 4s^1$	$[\text{Ar}] 4s^1$

b) The p-block elements

The p-Block comprises elements belonging to Group 13 up to 18. The elements of p-block and s-block are termed the representative elements or main group elements. The valence electron of p-block elements varies from ns^1np^1 to ns^2np^6 in each period. At the end of each period appears a noble gas element with a closed valence shell ns^2np^6 configuration. The p-block includes 6 groups such as groups 13,14,15,16, 17 and 18. The atoms of the elements belonging to these groups accept the last electron in 2p, 3p, 4p, 5p and 6p orbitals. Group 18 are called noble gases and all these elements have closed shell ns^2np^6 electronic configuration in the outermost shell. The noble gases are found in p-block. All the orbitals in the valence shell of the noble gases are completely filled by electrons and it is very difficult to alter this stable arrangement by the addition or removal of electrons. The noble gases thus exhibit very low chemical reactivity.

The p-block elements consist of both metals and non-metals but the number of non-metals is considerably higher than that of metals. The metallic character increases as we move down the group and non-metallic character increases from left to right along a period. The ionization energies of p-block elements are relatively higher compared to those of s-block elements. Most of them form covalent compounds. Some of p-block elements exhibit more than one oxidation state in their compounds and their oxidizing character increases from left to right in a period and reducing character increases from top to bottom in a group. Most of the p-block elements are highly electronegative and form acidic oxides.

c) The d-block elements

Elements in which the last electron enters any one of the five d orbitals are called **d-block element**. These elements comprise Group 3 to 12 in the centre of the Periodic Table (Figure 5.2). These elements are characterized by the filling of inner d orbitals by electrons and are therefore referred to as d-Block Elements. Their outer electronic configuration is $(n-1)d^{1-10}ns^{0-2}$. As these elements are transition metals, mostly of them form coloured ions and they display variable valence or oxidation states. However, Zn, Cd and Hg which have the electronic configuration, $(n-1)d^{10}ns^2$ do not show most of the properties of transition elements.

s block		d block										p block					18
1	2	3	4	5	6	7	8	9	10	11	12	13	14	15	16	17	He
Li	Be											B	C	N	O	F	Ne
Na	Mg											Al	Si	P	S	Cl	Ar
K	Ca	Sc	Ti	V	Cr	Mn	Fe	Co	Ni	Cu	Zn	Ga	Ge	As	Se	Br	Kr
Rb	Sr	Y	Zr	Nb	Mo	Tc	Ru	Rh	Pd	Ag	Cd	In	Sn	Sb	Te	I	Xe
Cs	Ba	La-Lu	Hf	Ta	W	Re	Os	Ir	Pt	Au	Hg	Tl	Pb	Bi	Po	At	Rn
Fr	Ra	Ac-Lr	Rf	Db	Sg	Bh	Hs	Mt	Ds	Rg	Cn	Nh	Fl	Mc	Lv	Ts	Og

f block

Figure 5.2: Elements of d-block

The properties of d-block elements are midway between those of s- block and p- block elements, they are divided into four series called 1st, 2nd, 3rd and 4th transition series. The first transition series contains 10 elements from scandium (Z=21) to zinc (Z=30); for those elements, 3d orbitals are being progressively filled in. The second transition series contains the elements from Y through Ag in which the 4d orbitals are being progressively filled. The third transition series also contains the elements La and the element Hf through Au in which the 5d orbitals are progressively filled. The fourth transition series also encloses the elements which include Rf through Rg with 6d orbitals being consecutively

The elements of d-block are hard, malleable and ductile metals with high melting and boiling point. Mercury is an exception, it is liquid at room temperature. Because they are metals, they are good conductors of heat and electricity.

Their ionization energy are between s and p block elements. Transition metals show variable oxidation states reason why they form both ionic and covalent compounds. In chemistry, catalysts used in different reactions are transition metals (i.e: V, Cr, Mn, Fe, Co, Ni, and Cu).

d) The f-Block elements

The f-block elements are found within the two rows of elements at the bottom of the Periodic Table. They are called the Lanthanides and include Ce (Z = 58) to Lu (Z = 71) and Actinides, Th (Z = 90) to Lr (Z = 103). All of these elements are characterized by the outer electronic configuration $(n-2)f^{1-14} (n-1)d^{0-1} ns^2$. The last electron added to each element is filled in f-orbital. These two series of elements are hence named the inner transition elements (f-block elements). They are all metals and display similar properties within each series. The f-block elements exhibit variable oxidation states, they have high melting and boiling point. They form complex compounds and most of the elements of the actinide series are radioactive.

Checking up 5.4

1. Which block that have a good tendency to form complex compounds?
2. Why d-block are called transition elements?
3. Why f-block are called inner transition elements?

5.6. Variation of Physical Properties down The Group and Across the Period

Activity 5.5

1. The elements in the periodic table display many trends which can be used to predict their physical properties. Explain three of the factors that you think can influence the physical properties of elements in the periodic table.
2. Discuss the trends of the above factors across a period and down a group in the periodic table.

The elements in the periodic table are arranged in order of increasing atomic number. All of these elements display several other trends and we can use the periodic law and table formation

to predict their physical properties. There are many noticeable patterns in the physical properties of elements as we descend in a group or move across a period in the Periodic Table.

Trends of physical and chemical properties are observed in the Periodic Table. There are factors that are the causes of those trends such as atomic radius, *ionization energy*, *electronegativity*, *electro positivity*, *electron affinity*, *melting and boiling point*, *density* and *metallic character*.

5.5.1. Atomic radius

The atomic radius of an atom is defined as half the distance between the nuclei of two atoms of the same element that are joined together by a single covalent bond.

Atomic radius of elements decreases as we move from left to right in periodic table. This is explained by the number of outer electrons and protons which increase while there is no change in the energy level. The results increase the attracting forces making the radius smaller.

Increasing nuclear charge (more protons) pulls the electrons closer to the nucleus, and the screening effect of inner electron shells will be the same for all members of a given period. The combined effect of both factors results is the electrons being pulled closer to the nucleus and a smaller radius.

On the other side, in the same group, as we go down, the atomic radius of elements increases. This is due to the energy level which increases when you move down in group of the periodic table, the attraction of electrons by protons decrease and atomic radius increases.

In general, atomic radii increase down a group because a new shell is added for each successive member of a group, leading to a greater radius. Then an increased screening effect of extra electron shells i.e. the nucleus has less of a pull on the outer electrons.

5.5.2. Electronegativity

Electronegativity is a measure of an atom's attraction for the shared pair of electrons in a bond. The charge in the nucleus increases from left to right across a period. The electronegativity of atoms is affected by both the atomic number and its size. The higher its electronegativity, the more an element attracts electrons. In general, the electronegativity of a non-metal is larger than that of metal. Trends are observed in the period (Figure 5.3) or in a group of the Periodic Table (Figure 5.4).

- **In a period**, the electronegativity increases from left to right. If the valence shell of an atom is less than half full, it requires less energy to lose an electron than to gain one. Conversely, if the valence shell is more than half full, it is easier to pull an electron into the valence shell than to donate one.

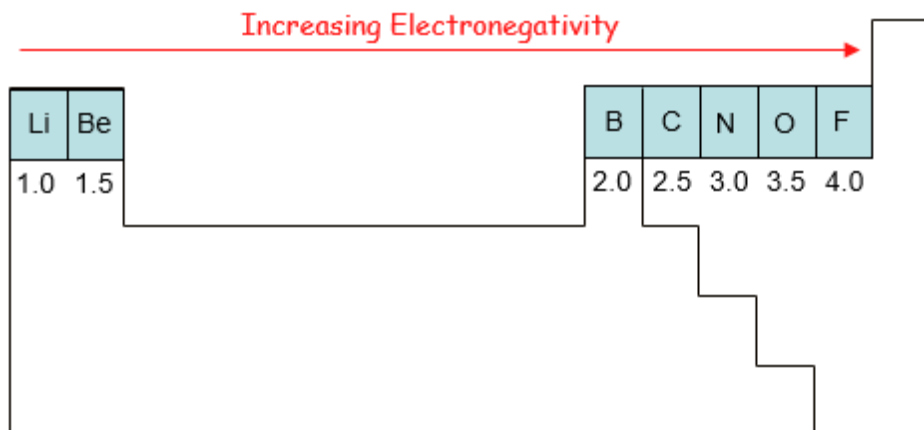

Figure 5.3: Variation of electronegativity across a period

- **In a group**, the electronegativity decreases from top to bottom. This is due to increase of energy levels down in a group, and thus there is an increased distance between the valence electrons and nucleus, or a greater atomic radius. The positive charge of the nucleus is further away from the valence electrons and is shielded by the extra inner electron shells.

Note:

- ❖ Since noble gases do not react or do not form chemical bonds, their electronegativity cannot be specified.
- ❖ The lanthanides and actinides possess more complicated chemistry that does not generally follow any trends. Therefore, they do not have electronegativity values.
- ❖ For the transition metals, the electronegativity does not vary significantly across the period and down a group. This is because their metallic character affects their ability to attract electrons easily as for the other elements.

According to these two general trends, the *most electronegative element is fluorine* and Francium is the least (Figure 5.4 and Figure 5.5).

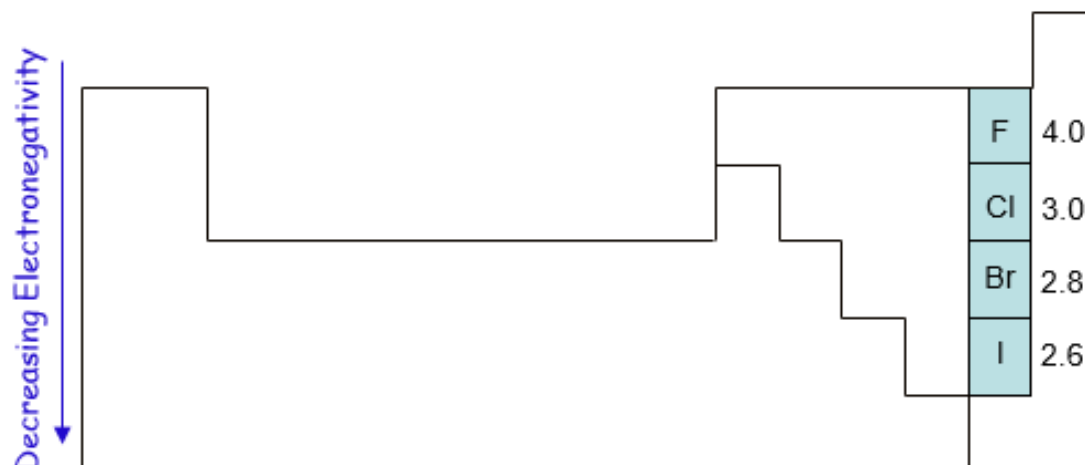

Figure 5.4: Variation of electronegativity down a group

The charge in the nucleus increases across a period. Greater is the number of protons, greater is the attraction for bonding electrons.

5.5.3. Ionization energy (I.E)

Ionization energy: it is the amount of energy required to remove an electron from a neutral gaseous atom. The lower this energy is, the more readily the atom loses electron and becomes a cation. Therefore, the higher this energy is, the more unlikely it is the atom to become a cation. We can distinguish, first, second, and third ionization. Helium is the element with the highest ionization energy (Zumdahl and Zumdahl, 2010). The noble gases possess very high ionization energies because of their full valence shells compared to the elements of group 1 (Table 5.5).

Table 5.5. First ionization energies (kJ/mol) for the alkali metals and noble gases

Group 1 (Alkali metals)		Group 8 (Noble gases)	
Atom	Ionization energy	Atom	Ionization energy
Li	520	He	2377
Na	495	Ne	2088
K	419	Ar	1527
Rb	409	Kr	1356
Cs	382	Xe	1176
		Rn	1042

As mentioned above, different types of ionization energy exist such as first and second ionization energy. In general, the second ionisation energy of an element is always greater than the first ionisation. In the following example, based on the electronic configuration of potassium K and magnesium Mg, the second ionization of K is higher than the second ionization of Mg. The second ionisation of K involves removing an electron from a stable electron arrangement which requires a lot of energy.

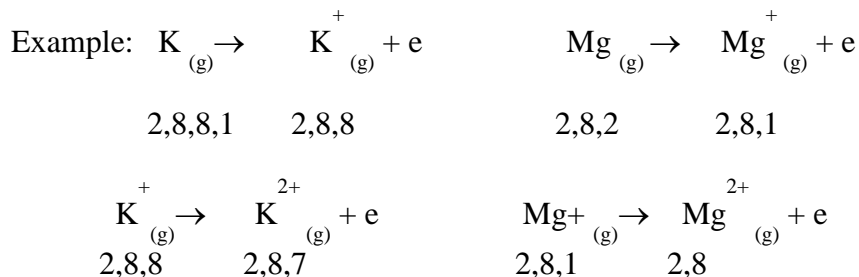

The ionization energy can vary across a period and down a group.

Across a period ionisation energies increase because the nuclear charge increases (greater positive charge on the nucleus) and holds the outer electrons more strongly. More energy needs to be supplied to remove the electron.

Note: A quick look for some exception, the first ionization energies of period 2, reveals unusually high values for Be and N. The reasons for this become evident if we look at the electronic configurations of these two elements: Be; $1s^2, 2s^2$ and N: $1s^2, 2s^2 2p^3$

Beryllium has 2s orbital which is full complete, it is small and the attraction of the nucleus toward valence electrons is high, therefore removing an electron from this element takes more energy than expected.

Down a group ionisation energies decrease because the outer electrons are further away from the nucleus. The screening effect of the inner electron shells reduces the nuclear attraction for the outer electrons, despite the increased (positive) nuclear charge.

5.5.5. The melting points and boiling points

Melting points and boiling points show periodic properties. The melting point is the amount of energy required to change the solid phase of a substance to a liquid. During the process of melting, attraction forces between molecules (or atoms for metals) are broken or weakened. Because temperature is directly proportional to energy, high bond dissociation energy correlates to a high temperature. Melting points are varied and do not generally form a distinguishable trend across the periodic table.

The melting and boiling points vary in a regular way or pattern depending on their position in the Periodic Table. In general the forces of attraction (intermolecular/interatomic bonding) for elements on the left of the table must be stronger, or more extensive than between the particles on the right.

For example going down in group 1, the melting point and boiling point of the alkali metals decrease. This is due to the force of attraction between the particles. However, going down in group 17 of the halogens the melting point increases meaning that there is an increase in the force of attraction between the particles. The illustrations below show the variation of melting and boiling point for some elements of the periodic table (Figures 5.6 and 5.7).

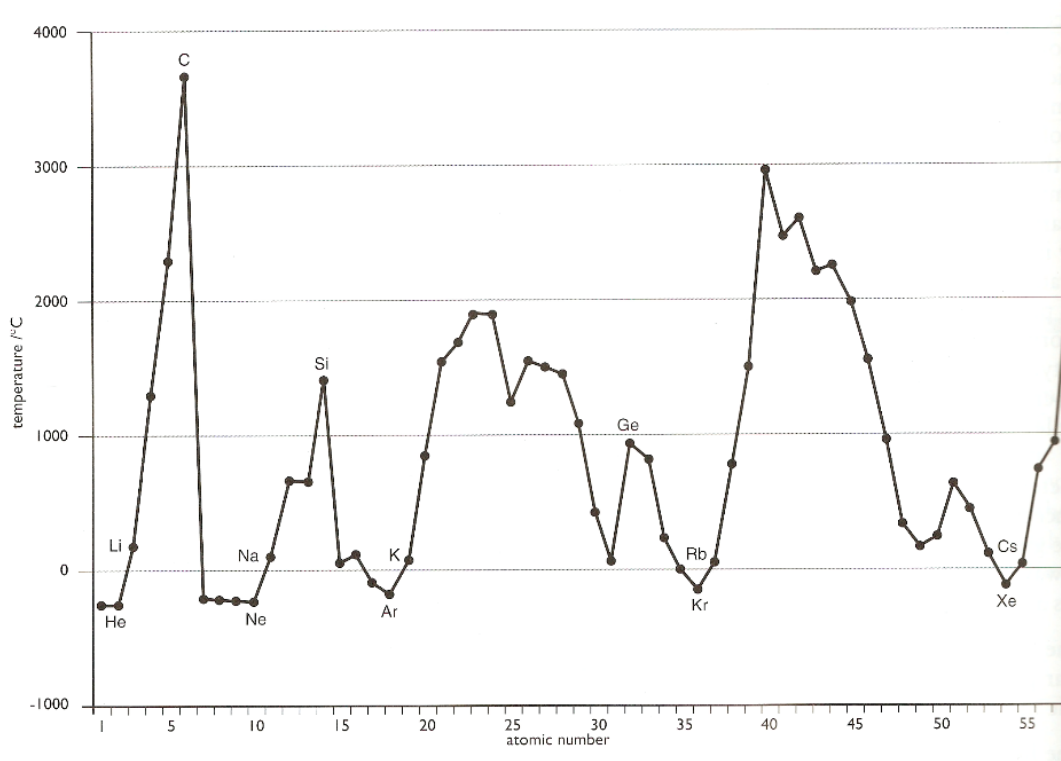

Figure 5.6: Variation of melting point with atomic number

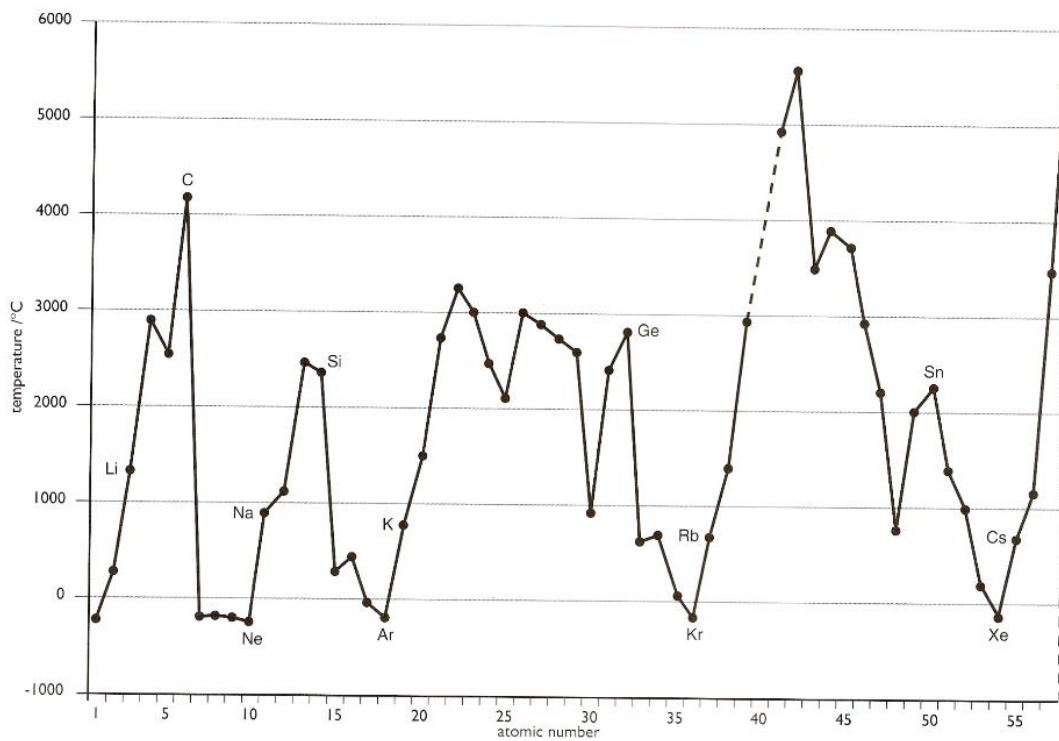

Figure 5.7: Variation of boiling point with atomic number

5.5.6. The density

The density of a substance is its mass per unit volume, usually in g/cm^3 . The density is a basic physical property of a homogeneous substance; it is an intensive property, which means it depends only on the substance's composition and does not vary with size or amount.

The trends in density of elements can be observed in groups and periods of the periodic table. In general in any period of the table, the density first increases from group 1 to a maximum in the centre of the period, and then decreases again towards group 18.

Going down a group gives an overall increase in density. The variation of density with atomic number is shown in the Figure 5.8.

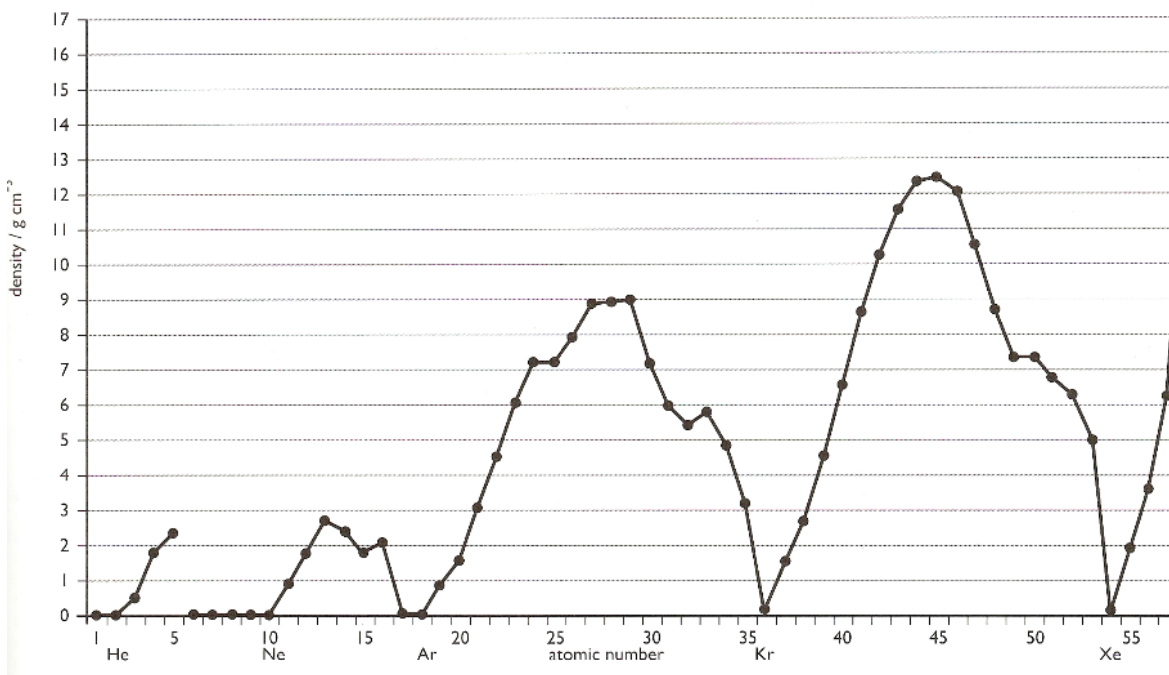

Figure 5.8: Variation of the density with atomic numbers

5.5.7. Electrical and thermal conductivity

The electrical conductivity is the ability of a substance to conduct an electric current.

The electrical conductivity of elements varies from metals to non-metals. The metals are good conductor of electricity. This is due to the presence of free electrons in metallic lattice. The capacity of metals to conduct heat is called thermal conductivity of metals. The conductivity is made of transfer of energy and the thermal conductivity in metal is due to heat transfer by free electrons from one end of metal to another end.

As we move across the period, the electrical conductivity remains high for the metals and then decreases for the non-metals while the thermal conductivity decreases.

1. Metallic character

Metallic character refers to the level of reactivity of a metal. Metals tend to lose electrons in chemical reactions, as indicated by their low ionization energies. Within a compound, metal atoms have relatively low attraction for electrons, as indicated by their low electronegativities. Metals are located in the left and lower three-quarters of the periodic table, and tend to lose electrons to nonmetals. Nonmetals are located in the upper right quarter of the table, and tend to gain electrons from metal. Metalloids are located in the region between the other two classes and have properties between them as well.

- Metallic character is strongest for the elements in the leftmost part of the periodic table and tends to decrease as we move to the right of any period.
- Within any group of the representative elements, the metallic character increases progressively going down.

2. The electron affinity (E.A)

The electron affinity is the ability of an isolated gaseous atom to accept an electron. Unlike electronegativity, electron affinity is a quantitative measurement of the energy change that occurs when an electron is added to a neutral gas atom. The more negative the electron affinity value, the higher an atom's affinity for electrons. In the periodic table, the first electron affinities of elements are negative in general except the group 18 and group 2 elements. The second electron affinities of all elements are positive. This is because the negative ion is a negative electric field. And if now the other electrons enter the negative field, energy has to be applied to the system to overcome the repulsion that the negative electric field interacts with the electrons.

The more the electron affinity value is negative, the higher is the electron affinity of an atom. Electron affinity decreases down a group of elements because each atom is larger than the atom above it (refer to atomic radius trend). This means that an added electron is further away from the atom's nucleus compared with its position in the smaller atom. With a larger distance between the negatively-charged electron and the positively-charged nucleus, the force of attraction is relatively weaker. Therefore, electron affinity decreases.

Moving from left to right across a period, the electron affinity increases because the electrons added to energy levels become closer to the nucleus and there is a stronger attraction between the nucleus and electrons.

Checking up 5.5

1. The following table shows a part of a periodic table. Students have to answer the following questions related to the table.

Period

Group										
1	1	2	11	12	13	14	15	16	17	
2	Li	Be			B	C	N	O	F	Ne
3	Na	Mg			Al	Si	P	S	Cl	Ar
4	K	Ca	Sc	Ti	Ga	Ge	As	Se	Br	Kr

Fill in the blank space with the correct term based on the above table.

- a. The element with the least nuclear charge isand the one with the highest nuclear charge

.....Nuclear charge of S isthan the nuclear charge of Se.
 As you go from Na to Cl along the period nuclear charge
 Effective nuclear charge....from B to Ga while it....from Na to Ar. Shielding or screening effect
 down the group butalong the period from left to right.
 Atomic size of Li is.... Than that of K. Element with the least atomic size is (10).....and the
 element with the highest atomic size is

Atomic size of Ca is Than atomic size of Be because number ofincreases down the
 group.

Atomic size from K to Kr because electrons are filled on the same shell, the
continuously increase and attraction force increases.

2. Analyze and complete the following concept map using: ionization energy, atomic size,
 electron affinity, electronegativity and metallic character.

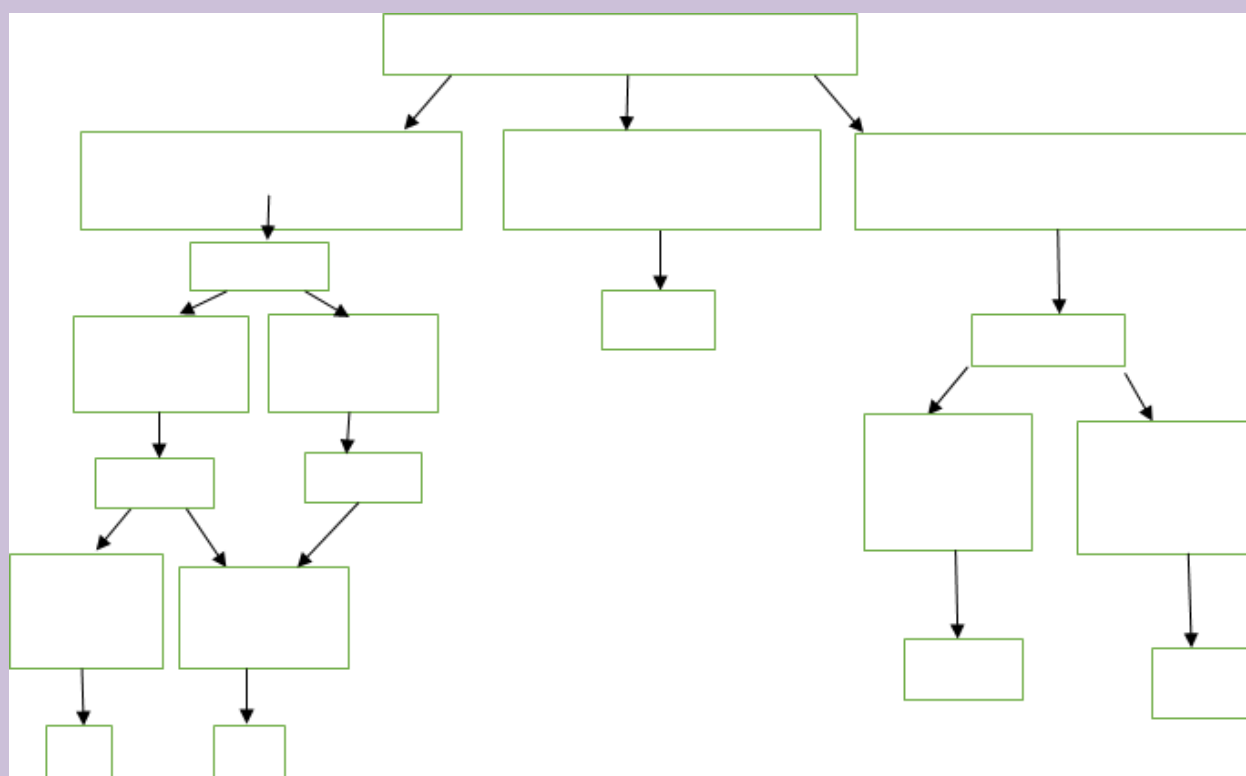

5.6. End unit assessment

- The following are coded groups/families of the representative elements of the periodic table (first 4 periods, s, p blocks only). The groups are in number of particular order. Use the hints below to identify the group and place of three elements of each group in their correct location in the periodic table: AOU, BVW, CKM, DLQ, ENT, FIJ, GPY, and HRS.

1							18
	2	13	14	15	16	17	

Hints

A has only one electron in p subshell

B is more electronegative than V

C has a larger atomic radius than both M and W

D has electronic configuration ending in p^5

E is one of the most reactive metals

F has a smaller ionization energy than J

G has only 1 energy level with any electrons

H has one more proton than O and is in the same period as O

I is the largest alkaline earth metal

J has one more proton than E

K has electron configuration ending in p^3

L has more filled energy levels than D

M is larger than K

N has the largest radius in its family

O is smaller than F but in the same energy level as F

P is smaller than Y

Q is the most reactive non-metal

R has the highest electronegativity in its family

T has the lowest density in its family

U more easily loses electrons (think about ionization energy) than either A or O

V has only 4 electrons in a p-subshell

W has 3 completely filled energy levels

Y has the lowest ionization energy in its family.

2. Based on the variation of ionization energy in groups and periods, how should you explain the variation of first and second ionization energy down a group and across a period?

3. Justify the following statements:

a) The first ionization energy of nitrogen is higher than that of oxygen even though nuclear charge of nitrogen is less compared to oxygen.

b) Noble gases are having high ionization energies.

4. Give reason

a. Alkali metals (group 1 elements) are not found free in nature.

b. Atomic radius of gallium is less than that of aluminium. (Z of Al = 13, Z of Ga = 31)

UNIT 6: TRENDS IN CHEMICAL PROPERTIES OF GROUP 1 ELEMENTS AND THEIR COMPOUNDS

Key unit competence: Compare and contrast the chemical properties of the Group 1 elements and their compounds in relation to their position in the Periodic Table.

Learning objectives

By the end of this unit, I will be able to:

- Describe and explain the physical properties of Group 1 elements in terms of metallic character
- and strength of metallic bond
- Describe and explain the reactivity of Group 1 elements with oxygen, water and halogens
- State and explain the properties of Group 1 oxides and hydroxides
- Explain the trends in the solubility of Group 1 compounds
- State the uses of Group 1 elements and their compounds
- Compare the reactivity of Group 1 elements
- Interpret the trends in the thermal decomposition of Group 1 carbonates and nitrates
- Perform experiments to test the alkalinity of Group 1 hydroxides
- Carry out flame test for the presence of Group 1 metal cations in solution.

Introductory activity

IUPAC Periodic Table of the Elements

1 H hydrogen 1.008 (1.00784, 1.0082)	2 He helium 4.0026											13 Al aluminium 26.982	14 Si silicon 28.086 (28.085, 28.086)	15 P phosphorus 30.974	16 S sulfur 32.06 (32.059, 32.076)	17 Cl chlorine 35.45 (35.446, 35.457)	18 Ar argon 39.948
3 Li lithium 6.94 (6.938, 6.947)	4 Be beryllium 9.0122											5 B boron 10.81 (10.806, 10.821)	6 C carbon 12.011 (12.009, 12.012)	7 N nitrogen 14.007 (14.006, 14.008)	8 O oxygen 15.999 (15.989, 16.000)	9 F fluorine 18.998	10 Ne neon 20.180
11 Na sodium 22.990	12 Mg magnesium 24.305 (24.304, 24.307)	3	4	5	6	7	8	9	10	11	12	13 Al aluminium 26.982	14 Si silicon 28.086 (28.085, 28.086)	15 P phosphorus 30.974	16 S sulfur 32.06 (32.059, 32.076)	17 Cl chlorine 35.45 (35.446, 35.457)	18 Ar argon 39.948
19 K potassium 39.098	20 Ca calcium 40.078(4)	21 Sc scandium 44.956	22 Ti titanium 47.867	23 V vanadium 50.942	24 Cr chromium 51.996	25 Mn manganese 54.938	26 Fe iron 55.845(2)	27 Co cobalt 58.933	28 Ni nickel 58.693	29 Cu copper 63.546(3)	30 Zn zinc 65.38(2)	31 Ga gallium 69.723	32 Ge germanium 72.630(8)	33 As arsenic 74.922	34 Se selenium 78.971(8)	35 Br bromine 79.904 (79.901, 79.907)	36 Kr krypton 83.798(2)
37 Rb rubidium 85.468	38 Sr strontium 87.62	39 Y yttrium 88.906	40 Zr zirconium 91.224(2)	41 Nb niobium 92.906	42 Mo molybdenum 95.95	43 Tc technetium 98.9062	44 Ru ruthenium 101.07(2)	45 Rh rhodium 102.91	46 Pd palladium 106.42	47 Ag silver 107.87	48 Cd cadmium 112.41	49 In indium 114.82	50 Sn tin 118.71	51 Sb antimony 121.76	52 Te tellurium 127.60(3)	53 I iodine 126.90	54 Xe xenon 131.29
55 Cs caesium 132.91	56 Ba barium 137.33	57-71 lanthanoids	72 Hf hafnium 178.49(2)	73 Ta tantalum 180.85	74 W tungsten 183.84	75 Re rhenium 186.21	76 Os osmium 190.23(3)	77 Ir iridium 192.22	78 Pt platinum 195.08	79 Au gold 196.97	80 Hg mercury 200.59 (200.58, 200.59)	81 Tl thallium 204.38 (204.38, 204.39)	82 Pb lead 207.2	83 Bi bismuth 208.98	84 Po polonium	85 At astatine	86 Rn radon
87 Fr francium	88 Ra radium	89-103 actinoids	104 Rf rutherfordium	105 Db dubnium	106 Sg seaborgium	107 Bh bohrium	108 Hs hassium	109 Mt meitnerium	110 Ds darmstadtium	111 Rg roentgenium	112 Cn copernicium	113 Nh nihonium	114 Fl flerovium	115 Mc moscovium	116 Lv livermorium	117 Ts tennessine	118 Og oganesson



57 La lanthanum 138.91	58 Ce cerium 140.12	59 Pr praseodymium 140.91	60 Nd neodymium 144.24	61 Pm promethium 144.9126	62 Sm samarium 150.36(2)	63 Eu europium 151.96	64 Gd gadolinium 157.25(3)	65 Tb terbium 158.93	66 Dy dysprosium 162.50	67 Ho holmium 164.93	68 Er erbium 167.26	69 Tm thulium 168.93	70 Yb ytterbium 173.05	71 Lu lutetium 174.97
89 Ac actinium 227.04	90 Th thorium 232.04	91 Pa protactinium 231.04	92 U uranium 238.03	93 Np neptunium	94 Pu plutonium	95 Am americium	96 Cm curium	97 Bk berkelium	98 Cf californium	99 Es einsteinium	100 Fm fermium	101 Md mendelevium	102 No nobelium	103 Lr lawrencium

For notes and updates to this table, see www.iupac.org. This version is dated 28 November 2016. Copyright © 2016 IUPAC, the International Union of Pure and Applied Chemistry.

6.1. Occurrence and physical properties of group 1 elements physical state metallic character physical appearance and melting point

Activity 6.1.a

1. Study the following table of data and answer the questions that follow

Data

Element	Atomic No.	Group	Period	Melting points (°C)	Van de Waals/atomic radius (nm)	Pauli electro-negativity (EN)	1 st ionization energy (KJmol ⁻¹)
Li	3	1	2	180	0.15	1.0	520
Na	11		3	98	0.19	0.9	500
K	19		4	64	0.23	0.8	420
Rb	37		5	39	0.250	0.8	400
Cs	55		6	29	0.26	0.8	380
Fr							

a) What's meant by 1st ionization energy ?

b) Explain the trend in 1st ionization energy for group 1 metals down the group.

c) What is the relationship between melting point and atomic radius in group 1 element? Explain this trend.

2. What do you know about Group 1 elements?

3. Do you know any compound of a group 1 element? If yes, what is its application in our daily life?

Group 1 elements are: lithium (³Li), sodium(¹¹Na), potassium(¹⁹K), rubidium(³⁷Rb), cesium(⁵⁵Cs) and Francium(⁸⁷Fr); they are characterised by valence electronic structure ns^1 and that is why they are called s-block elements.

Although hydrogen has the same valence of ns^1 , it behaves differently from the others in many aspects; for example: hydrogen is a gas at room temperature whereas all other members are solid. Hydrogen behaves as a metal in some compounds when it combines with non-metals, and as a non-metal when it combine with very active metals. For this reason, the study of hydrogen is presented separately from the other members of group 1 elements.

Francium is exceptionally rare. It is formed by the radioactive decay of heavier elements.

Because Francium is both rare and highly radioactive, few of its properties have been determined and we are not going to talk much about it in this Unit.

Physical Properties of Alkali Metals

Activity 6.1.b

In groups, learners make research in libraries / internet and discuss on the physical properties of group 1 elements and or explain the following statements

a) Group 1 elements show weak metallic bonding

b) Atomic radius of Na is smaller than the corresponding ion Na⁺

c) The shining appearance of metals disappears after a certain period of time.

Group 1 elements are grey metals, soft, and can be easily cut with a knife to expose a shiny surface which turns dull on reaction with oxygen in air.

1. They have low melting and boiling points. They show relatively weak metallic bonding as only one valence electron is attracted by the nucleus. Also they have a big atomic radius and the attraction of nucleus toward the valence electron is weak.
2. They are good conductors of heat and electricity
3. They have a low ionisation energies that decreases down the group
4. They have low density compared to other metals and Li, Na and K are less dense than water
5. Group 1 metals color flames: When alkali metals are put in a flame they produce characteristic colors.

Table 1: Physical properties of group 1 elements

Element	³ Li	¹¹ Na	¹⁹ K	³⁷ Rb	⁵⁵ Cs	⁸⁷ Fr
Electron structure	(He)2s ¹	(Ne)3s ¹	(Ar)4s ¹	(Kr)5s ¹	(Xe)6s ¹	[Rn]7s ¹
First ionization energy(kj/mol)	520	500	420	400	380	393
Atomic radius/nm	0.15	0.19	0.23	0.25	0.26	0.26(extrapolated)
Melting point/(⁰ C)	180	98	64	39	29	27-30?
Boiling point/(⁰ C)	1330	892	760	688	690	680?
Density/g cm ⁻³	0.53	0.97	0.86	1.53	1.90	2.8-3.0?

Checking up 6.1

1. Discuss how the ionization energies vary in function of atomic radius for group 1 elements.
2. Is there any relationship between the atomic radius and the melting point in group 1 elements? Yes or No. Justify your answer
3. Why group 1 elements are said to be good conductors of electricity? Illustrate your answer by explaining the metallic bonding that is involved.
4. The following table shows 3 unknown group 1 metals X, Y, Z and some of their physical properties. Predict among the alkalis metal (Cs, Li, K), which one should correspond to X,Y,Z. Justify your answer

Element	Mpt(⁰ C)	Van der Waals/atomic radius(nm)	1 st IE(kJmol ⁻¹)
X	64	0.23	420
Y	180	0.15	520
Z	29	0.26	380

6.2. Reactivity of group 1 elements with oxygen, water and halogens

Activity 6.2 (a)

Analyse the case study below and answer the related question:

1. In groups learners discuss about the following scenario and compare their findings to the reactivity of a chemical element in term of the variation of atomic radius

Suppose that a hen walking in the garden with its chicks. Some of the chicks are feeding themselves just near the hen (mother). Other chicks are feeding themselves far away from the mother. Which ones of the two groups of chicks will be an easy prey of a predator? Explain.



Now extend your reasoning to the behavior of group 1 element and explain the following statement

Group 1 elements react by losing their single electron in outermost shell. Arrange them in order to show which one loses easily the single electron and which one loses electron with difficult.

2. Consider a case of people who are warming around a fire; some are near, other are a little bit far; who will feel the heat of the fire more than the other?



FIG 3

These activities show the distance between two object affect interactions between them. The hen mother cannot protect the chicks that are far from her. In the other case, people who are far from the fire feel less the heat of the fire.

This resembles to the interactions between the nucleus and the valence electrons. The attraction between the nucleus and the valence electron decreases with increasing distance between the nucleus and the valence electrons.

When the atomic radius and volume increase, the distance between the nucleus and the valence electrons increases, the attraction between the nucleus and the valence electrons decreases, and it becomes easier to remove the valence electrons.

This explains the of group 1 metals: they have low ionization energy; lose easily the only one valence electron to form a mono-positive cation (M^+) with a rare gas electronic structure, and consequently are very active metals.

Activity 6.2 (b)

a) Given the following element of group 1 (Na ($Z=11$), Li ($Z=3$), Cs ($Z=55$), K ($Z=19$), Rb ($Z=37$)). Arrange them according to their increasing reactivity and justify why.

b) Establish the electronic structure for the following species and explain how you get it Na^+ , Na^{2+} , Na^- . Which one is stable and why?

6.2.1. Reactions with Oxygen

Activity 6.2.1

Experiment: burning an alkali metal in air/oxygen

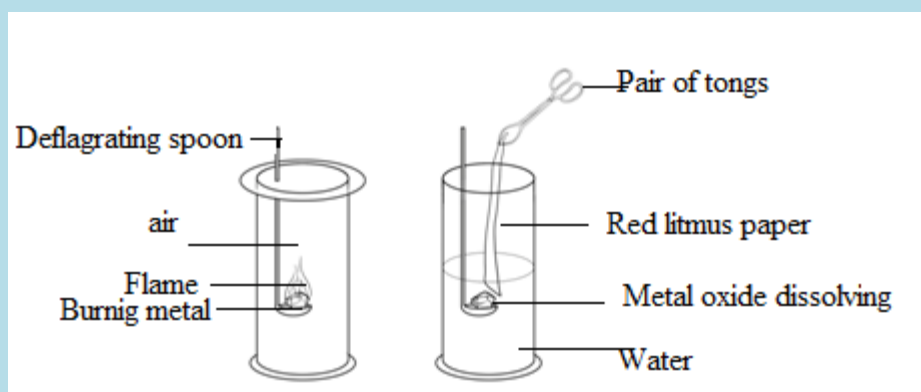

Apparatuses: deflagrating spoon, Bunsen burner, glass beaker, filter paper,

Chemicals: lithium, sodium, potassium, water, and red litmus paper

Other requirements: knife, match box and petroleum gas

Procedure:

1. Cut a small piece of lithium and wrap it in piece of filter paper to remove the oil.
2. Place it on to a deflagrating spoon and heat it in a non luminous flame.
3. Observe what happens
4. When combustion is complete, dip the deflagrating spoon into a beaker of 100 ml filled up to 50 ml of water.

5. Stir the water with the spoon and then drop a piece of litmus papers into the solution in the beaker. Observe
6. Repeat the experiment with sodium and potassium

Task on the experiment:

- a) Write the equations of reactions that take place when each metal is burnt in air
- b) Name the product that was formed in each case.
- c) What are the color changes when the aqueous solutions above are tested with litmus paper? Explain why?
- d) Write the equations of reaction between each product in (b) with water

Alkali metals form oxides when they burn in air or in oxygen. The nature of the oxides varies among the elements. For example lithium forms normal oxide (Li_2O), sodium forms peroxide (Na_2O_2) and the remaining elements mainly form superoxides with very little amounts of peroxides:

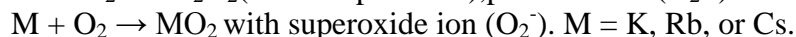
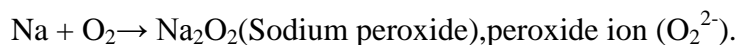
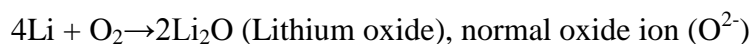

The reason for formation of peroxides and superoxide as we move down the group is due to increased reactivity of Group 1 metals down the group.

Oxides formed by group 1 metals are highly soluble in water and form metal hydroxides giving strongly alkaline solutions:

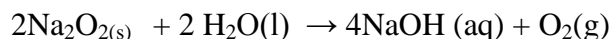
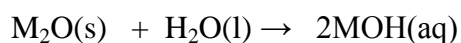

Hence Group 1 metals form basic oxides.

All group 1 metals are active metals, but there are differences within the group. The reactivity increases down the group due to the increase of atomic radius which results in the decrease of attraction between the nucleus and the valence electron, which requires less energy to remove the electron down the group.

6.2.2. Reaction with water

Activity 6.2.2 Experiment to investigate the reaction of alkalis metals with water

Procedure:

Cut a small piece of sodium metal and put it on water in wide beaker and observe.

Test the obtained solution with red and blue litmus papers and observe.

Questions

1. Why sodium is so easy to cut?
2. What are the observations when sodium is placed on water in the beaker
3. Explain the observation when test of red and blue litmus paper is performed on the resulting solution and write the equation of the reaction that takes place to explain you answer

Alkali metals react with water and form hydroxides along with liberation of hydrogen:

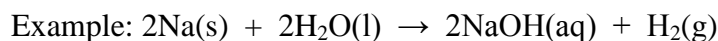
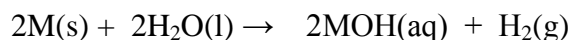

Where M represents any group 1 metal, MOH represents the corresponding hydroxide such as sodium hydroxide. This reaction explains why it is said that group 1 metals reduce water (where the ion H^+ from dissociation of water is reduced to H_2 molecule). This reaction where group 1 metals react with water to form an alkaline solution is at the origin of their name of “**alkali metals**”.

As said previously, the reactivity of Group 1 metals increases as we move down the group.

The reaction with water can be used to illustrate the increasing reactivity on descending the Group. Li reacts slowly with water, with effervescence; sodium reacts violently fizzing (a hissing sound is heard) and skating about on the water surface, a colorless gas is evolved; K reacts more violently and ignites on contact with water; Cs sinks in water, and the rapid generation of hydrogen gas under water produces a shock wave that can shatter a glass container.

The chemistry of Li shows some anomalies, as the cation Li^+ is so small that it forms covalent compounds.

6.2.3. Reaction with halogens

Activity 6.2.3

- a) In terms of s, p, d, f orbitals write the electronic configuration of chlorine (Z=17), bromine (Z=35) and iodine (Z=53)
- b) Deduce the valency of each element.
- c) Write molecular equations, complete and balance them when
 - Sodium reacts with bromine
 - Potassium reacts with iodine
 - Lithium reacts with chlorine

Alkali metals react with halogens very easily forming halides. The reactivity of alkali metals with halogen increases from Li to Cs.

$2M(s) + X_2 \rightarrow 2MX(s)$ X₂ is any element of group 17 (halogens)

Checking up 6.2

1. An element J has 19 as atomic number while the element A has 35 as atomic number.
 - a) Write their electronic structure in term of s, p, d, f orbitals and deduce their respective valencies.
 - b) The element J is able to react with oxygen gas by forming two types of oxides
 - i) Write the formula of the 2 oxides that can be formed between the element J and oxygen
 - ii) Write the formula of the compound formed between J and A
 - iii) What type of bond does exist between J and A. Justify your answer.
 - c) Show how you would write the equation of reaction between J and water supposing that J stands for the real symbol of the element.
 - d) When the reaction stated in (c) takes place a colorless solution and a colorless gas are formed.
 - i) Which test would you use to identify each product of the reaction, by stating the reagent and related observations?

6.3. Properties of group 1 oxides and hydroxides

Elements of group 1 are highly reactive and form a variety of compounds. Two of the most important are Oxides and Hydroxides.

6.3.1 Oxides

Alkali metals form oxides when they burn in air or in oxygen as seen in point (6.2.1):

They are also formed by thermal decomposition of corresponding hydroxides

Example: $2KOH(s) \xrightarrow{\text{heat}} K_2O(s) + H_2O(g)$

6.3.2. Hydroxides

As said above hydroxides are formed when the metals or metals oxides are dissolved in water. In solid state, these hydroxides dissolve very easily in water and in alcohol. They dissociate completely in water to form alkaline solution; hence they are strong bases. The basic character of the hydroxides increases as we move down the group.

Checking up 6.3

1. Complete and balance the reactions when water is reacted with the following:
 - a) Potassium metal
 - b) Potassium oxide
2. Lithium hydroxide decomposes on heating. White powder X and a colorless gas Y is released and condenses in a colorless liquid.
 - i) Write the chemical formula of X.
 - ii) Propose a chemical test to identify Y
3. Explain why Group 1 metals form ionic compounds?

6.4. The effect of heat on Group 1 carbonates and nitrates

6.4.1. Heating the nitrates

Activity 6.4.1

Experiment: effect of heat on nitrates.

In groups learners perform the following experiment, discuss and make conclusions by explaining the observed phenomena, and write involved chemical reactions.

Apparatus: glass test tubes, pair of tongs, wooden splint/match stick, Bunsen burner/heat source and spatula.

Chemicals: Lithium nitrate, potassium nitrate

Other requirements: match box

Procedure:

I.1. Take two spatula end full of lithium nitrate into a test tube and heat it strongly until there is no further change.

2. Test the gases evolved with a damp blue litmus paper and a glowing splint.

3. Observe and make conclusions on your observations.

II. Repeat the procedure but using potassium nitrate/sodium nitrate

Laboratory apparatus setting for thermal decomposition of a salt

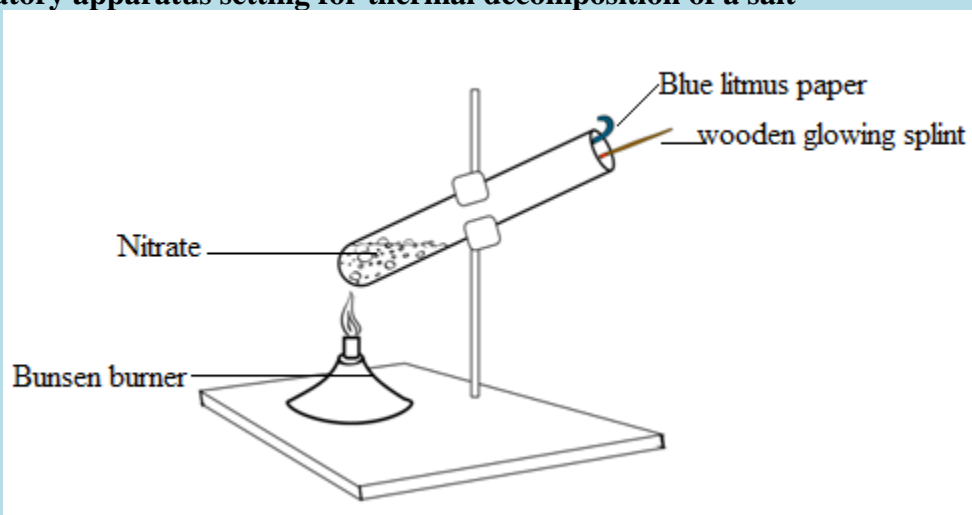

Group 1 compounds are generally more stable to heat.

Therefore Group 1 nitrates (except lithium nitrate) decompose on heating in Bunsen flame to form their corresponding nitrites (which are stable) and oxygen

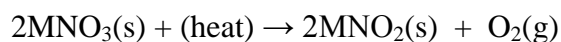

All nitrates from sodium to cesium decompose in this same way.

Lithium nitrate behaves differently, producing lithium oxide, nitrogen dioxide and oxygen.

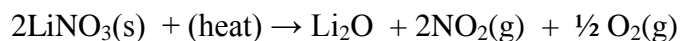

Checking up 6.4.1

- a) Differentiate between KNO_3 and LiNO_3 in terms of their thermal decomposition.
- b) One of the two compounds decomposes releasing a colored gas that turns blue litmus paper to red.
 - i) State which one.
 - ii) Give the name, the formula and the color of that gas

6.4.2. Heating the carbonates

Activity 6.4.2

Experiment: effect of heat on carbonates of group 1 elements

In groups learners perform the following experiment, discuss and make conclusions by explaining the observed phenomena, and write chemical reactions.

Apparatus: glass test tubes, pair of tongs, Bunsen burner/heat source and spatula.

Chemicals: lithium carbonate, calcium carbonate, potassium carbonate and sodium carbonate, lime water

Other requirements: match box.

Procedure

I.1 Take two spatula end full of lithium carbonate into a test tube and heat it strongly until there is no further change.

2. Test the gases evolved with a damp blue litmus paper and lime water into another glass test tube as shown in the figure

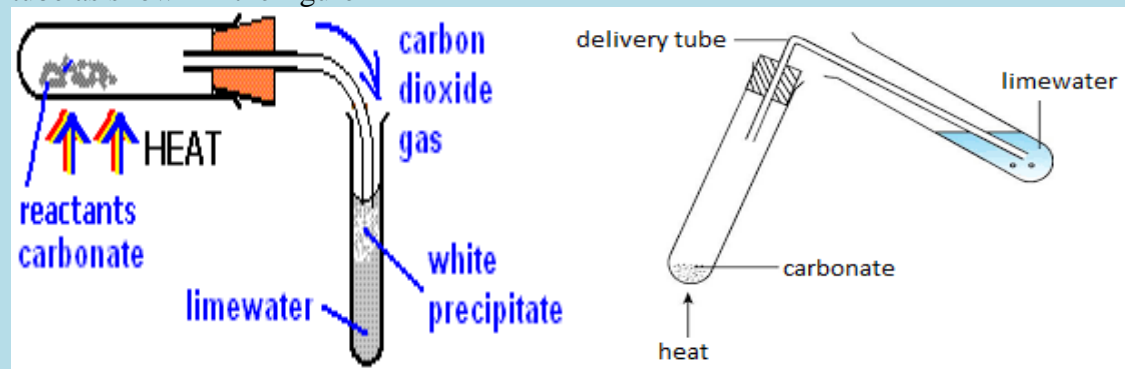

3. Observe and make conclusions on your observations.

II .Repeat the procedure but using calcium carbonate, potassium carbonate /sodium carbonate

Most carbonates of group 1 resist to heat.

However in **Group 1**, lithium carbonate decomposes on heating, producing lithium oxide and carbon dioxide.

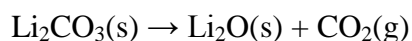

The remaining of the Group 1 carbonates does not decompose at Bunsen flame temperatures.

Checking up.6.4.2

Li_2CO_3 decomposes on heat releasing a colorless gas.

- a) Write the equation of thermal decomposition of Li_2CO_3
- b) What do you observe when the evolved gas is tested by lime water and blue litmus paper? Explain

6.5. Solubility of group 1 compounds**Activity 6.5**

- a) Group 1 elements form ionic compounds.
 - (i) Explain why.
 - (ii) State the properties of ionic compounds
- b) Explain why lithium form compounds with a covalent character contrarily to other component of the same group. State the properties of covalent compounds
- c) Both hydroxides and carbonates of lithium are less soluble than other hydroxides and carbonates of group 1. Why?

All group 1 salts and hydroxides are soluble in water.

However LiCO_3 , LiOH are less soluble of group 1 compounds due to their high covalent properties.

6.5.1. Carbonates

The carbonates in the Group 1 are all very soluble - increasing to an astonishing 261.5 g per 100 g of water at 20°C temperature for cesium carbonate.

The least soluble Group 1 carbonate is lithium carbonate. A saturated solution of it has a concentration of about 1.3 g per 100 g of water at 20°C.

Solubility of the carbonates increases as you go down Group 1.

6.5.2. Hydroxides

Hydroxides of Group 1 are even more soluble.

The least soluble hydroxide in Group 1 is lithium hydroxide - but it is still possible to make a solution with a concentration of 12.8 g per 100 g of water at 20°C. Solubility of the hydroxides increases as you go down Group 1.

6.5.3. Sulphates

The solubility of sulphates behaves in different way from carbonates and hydroxides. Solubility of group 1 sulphates decreases as you go down the group.

Checking up 6.5

Arrange the following compounds in ascending order of their solubility:

- RbCl, NaCl, LiCl, KCl, CsCl
- Cs₂SO₄, Li₂SO₄, Na₂SO₄, Rb₂SO₄, K₂SO₄

6.6. Flame Test for Li⁺, Na⁺ and K⁺

Activity 6.6: Experiment: Flame test of alkalis metals

Materials: Mortar and pestle, beakers, Lithium carbonate, potassium sulphate, sodium sulphate

Procedure: Flame test wire /magnesia rod

NB: Wear your safety glasses.

Dip the flame test wire/magnesia rod in the salt to be tested. Some of the salt should stick to flame test wire/magnesia.

Gently wave the flame test wire/magnesia rod in the flame of the Bunsen burner and note the color given of



Examples of flame test

Repeat the experiment for each of the other salts. To avoid cross contamination, use a separate splint/flame test wire for each salt. Again, note the color in each case. If you are given an unknown salt, you should be able to identify the metal in the salt from the results of your experiment. The following are the flame colors for respectively K, Na, Li

Below are examples of flame tests for Na, K, and Li.



Student Questions

What color is observed in each case when the following salts are heated in a flame: lithium carbonate, sodium sulfate, , potassium sulfate?

Alkali metals color flames

When the element or its compound is placed in a flame, the heat provides sufficient energy to promote the outermost electron to a higher energy level. On returning to the ground level, energy is emitted and this energy has a wavelength in the visible region that is seen as color.

Table 2: Group 1 metals and their corresponding flame colors

Element	Flame color
lithium	Deep red
Sodium	Yellow
potassium	Lilac/violet
Rubidium	Red
cesium	blue

Checking up 6.6

Describe a chemical test to distinguish between 2 salt solutions below and predict expected results for:

- Solutions of CsCl and KCl
- Solutions of NaCl and LiCl

6.7. Uses of group 1 elements and their compounds

Basically, the use or application of any elements is determined by the chemistry and the physical properties of the particular element. Hereafter are some of the uses and applications of group 1 metals.

Activity 6.7

Make research on internet and in library about the use of group 1 elements and present your findings

- Lithium: Used for making alloys especially with aluminium to make aircraft parts, which are light and strong.
- Due to its size and electropositivity (opposite of electronegativity), lithium is used in both primary and secondary lithium batteries. Lithium is used in light weight electrical batteries of the type found in clocks and watches, heart pacemakers (a small piece of electronic equipment connected to someone's heart to help the heart muscles move regularly).
- Lithium carbonate, Li_2CO_3 , is used to toughen glass.
- Caustic soda, NaOH, and soda ash, Na_2CO_3 are the most important alkali used in industry. Both find applications in paper making, alumina, soap, and rayon. Na_2CO_3 (soda ash) is used in water treatment.
- NaOCl is used as bleaching agent and disinfectant
- NaCl is used in seasoning food, preparing hydrogen chloride gas, in soap production, manufacture of sodium, chlorine, sodium hydroxide and sodium carbonate.
- Molten sodium is used as a coolant in nuclear reactor. Its high thermal conductivity and low melting temperature and the fact that its boiling temperature is much higher than that of water make sodium suitable for this purpose.

- Sodium wire is used in electrical circuits for special applications. It is very flexible and has a high electrical conductivity. The wire is coated with plastics to exclude moisture.
- Sodium vapor lamps are used for street lighting; the yellow light is characteristic of sodium emission.
- Sodium amalgam (alloy with mercury) and sodium tetrahydridoborate, NaBH_4 , are used as reducing agents.
- Sodium cyanide is used in the extraction of silver and gold.

Checking up 6.7

1. Discuss the uses of sodium reference to its different reactions
2. Explain how sodium works
3. why sodium is it coated with plastic?

6.8 Hydrogen

Although hydrogen has the same valance electronic structure as Group 1 elements, $\text{H}[1s^1]$, it is not generally studied with the other elements of the group. Even some Periodic Tables do not put H in Group 1 column.

This is due the fact hydrogen has specific properties that distinguish it from the other elements of Group1. Hydrogen is the smallest chemical element, with only 1 electron in its electronic structure. Hydrogen is a gas, whereas other Group 1 elements are metals, all solid at room temperature. In some compounds with non-metals, hydrogen tends to lose electron and form polar compounds such as $\text{H}^{\delta+}\text{Cl}^{\delta-}$, but when it reacts with active metals, it behaves as a non-metal and capture electron to form hydride such as Na^+H^- .

All this justify why the study of hydrogen is separated from the study of other Group 1 elements.

6.8.1. Properties of hydrogen atom

Hydrogen is the first element in the periodic table. It is the simplest and smallest element of the chemical elements.

It is formed by only one electron and one proton, with the simplest nucleus. Its electron configuration is $1s^1$ (similar to the electron configurations of group 1 elements).Hydrogen is colorless, odorless, and tasteless gas.

Table 3: Properties of hydrogen

Mass number	1.008
Electronic structure	$1s^1$

Ionization energy	1312KJ/mol
Melting point °C	-259
Boiling point °C	-253
Density/gL ⁻¹	0.09

Hydrogen exists as a diatomic molecule in its gaseous state, H₂.

H₂ is small and non-polar, so H₂ molecules can only attract each other through weak Van der Waals forces.

Hydrogen is the most abundant element in the universe and accounts for 89% of all atoms.

There is little free hydrogen on earth because H₂ gas is so light that it moves very fast and can escape the Earth's gravitational pull

6.8.2. Production of hydrogen

a) From methane gas

Example:

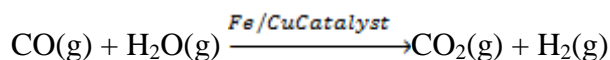
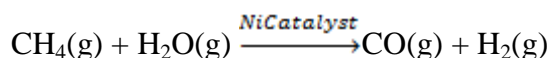

b) Electrolysis of water

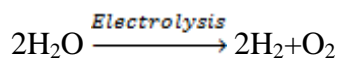

c) Laboratory preparation

Metals are reacted with dilute acids. Group 1 metals are not used because the reaction with acid is violent and dangerous.

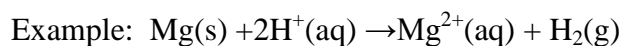

6.8.3. Uses of hydrogen

One third of the hydrogen produced is used for hydrometallurgical extractions of copper and other materials since hydrogen is a reducing agent. Half of the hydrogen is used in manufacturing of ammonia.

Hydrogen is also used in the manufacture of saturated oil(solid), such as margarine, from unsaturated oil (liquid) by hydrogenation reaction. Hydrogen is used as fuel in space rocket/space shuttles.

6.8.4. Chemical properties of hydrogen

Hydrogen can form both cations (H^+) and anions (H^-). It has an intermediate electronegativity. Hydrogen forms covalent bonds with nonmetals where it bears a partial positive charge, $H^{\delta+}$, and ionic hydrides with very active metals where it forms a hydride ion H^- .

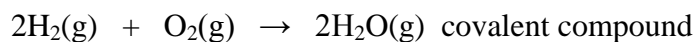

Examples: (a) Covalent compounds: NH_3 , H_2O , HF , and SiH_4

(b) Ionic compounds: CaH_2 , NaH , KH

When bonded to very electronegative elements, O, F, N, hydrogen is responsible of hydrogen bonding, a strong force between covalent molecules having O-H, F-H, and N-H in their structure. The figure below shows the formation of hydrogen bonds, represented by a dotted line, between molecules of hydrogen fluoride and between molecules of ammonia.

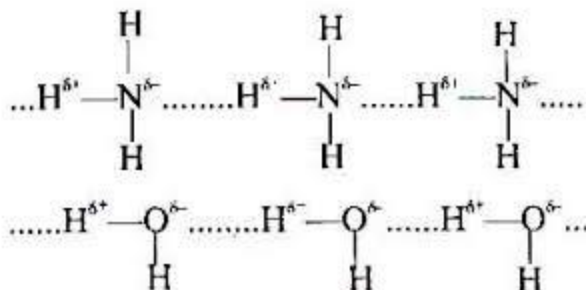

Consequences of the presence of hydrogen bond in a compound

Because of the presence in a compound of hydrogen bond, a strong force that requires more energy to overcome, this compound will possess higher melting and boiling points than the compounds of comparable molecular mass but without hydrogen bond.

This explain why water has an abnormally high melting and boiling points compared to other hydrides of Group 16 elements .

The presence of O-H and N-H groups in a compound makes that compound very soluble in water because of strong interactions between water molecules and the molecules of the solute containing such groups; e.g. alcohols, ammonia, amines, etc....

Hydrogen bond is responsible in maintaining the two chains of DNA together.

NOTE:

For more information see unit 4(inter-molecular forces)

6.9. End unit assessment

1. a) Arrange the following salts from the least soluble in water to the most soluble and justify your choice: KCl , $NaCl$, $CsCl$, $LiCl$, $RbCl$.

b) As student in research you would like to distinguish between the above salts. Which quick

chemical test will you carry out and what observations do you expect from that experiment?

2. Sodium is reacted with water:

- a) What will happen?
- b) Write the equation of the reaction between Na and water
- c) How would you test for the presence of the products formed?

3. You are provided with the following chemical compounds KNO_3 , Li_2CO_3 , LiNO_3 , and K_2CO_3 . Identify which one is described as follows:

- a) A soluble compound which does not decompose on heat
- b) A soluble compound which may decompose on heat releasing a gas that relights a glowing splint.
- c) A soluble compound which decomposes on heat releasing brown fumes and a colorless gas that supports combustion.
- d) A slightly soluble compound which decomposes on heat and releases a colorless gas that turns lime water milky.

4. Group 1 consists of the elements Li, Na, K, Rb, and Cs.

(a) The first member of the group often shows anomalous properties. Give two properties in which the behavior of Lithium is abnormal and explain why.

(b) How does each of the following properties of the elements in Group 1 change with the increasing atomic number? And explain why.

- i) Atomic radius
- ii) Ionization energy
- iii) Reducing properties
- iv) Reactivity with water
- v) Electronegativity

(c) How will successive ionization energies of Na vary?

(d) Why is the Na^+ ion formed in normal chemical reaction rather than Na^{2+} ?

(e) How are ionization energies related to the reactivity of these elements?

UNIT 7: TRENDS IN CHEMICAL PROPERTIES OF GROUP 2 ELEMENTS AND THEIR COMPOUNDS

Key unit competence: compare and contrast the properties of the group 2 elements and their compounds in relation to their position in the periodic table.

Learning objectives

By the end of this unit, I will be able to:

- Describe the physical properties of group 2 elements.
- Describe the properties of group 2 oxides and hydroxides.
- Explain the trends in the thermal decomposition of group 2 carbonates and nitrates.
- Explain the trends in the solubility of group 2 compounds.
- State the uses of group 2 elements and their compounds.
- Describe the industrial manufacture of cement.
- Discuss the environmental and health issues associated with the manufacturing of the cement.
- Perform experiments to compare and contrast the reactivity of group 2 elements.
- Write balanced equations of the reactions of group 2 elements, different elements and the compounds.
- Illustrate practically the trends in solubility and thermal decomposition of group 2 compounds.
- Test the alkaline character of group 2 hydroxides.
- Be aware that the compounds of beryllium are different from the compounds of the other group elements.
- Perform chemical test for the presence of group 2 cations in solution.
- Suggest preventive measures for environmental and health issues associated with the manufacture of the cement.
- Appreciate the logic underlying the position of elements in the periodic table, their electronic structure and the properties.
- Appreciate the application of the chemistry of group 2 elements and their compounds in the social economic development.
- Develop the team work approach while performing experiment and writing field –study reports.
- Develop the attitude of sustainable exploitation of natural resources.
- Stimulate the culture of entrepreneurship in the area of chemistry.

Introductory activity 7

Complete the table below to identify the group 2 elements in the substances found in our surroundings: at home and at the school.

Substance	Element	Occurrence
Chalk		
Slaked lime (ishwagara)		

Limestone		
Medicine of Paris	plaster/Plaster	
Malox drug		

Group 2 elements are located at the left section of the Periodic Table of Chemical Element, second column; they are: beryllium (${}^4\text{Be}$), magnesium (${}^{12}\text{Mg}$), calcium (${}^{20}\text{Ca}$), strontium (${}^{38}\text{Sr}$), barium (${}^{56}\text{Ba}$) and radium (${}^{88}\text{Ra}$). All Group 2 elements are metals, solid at room temperature.

They are characterized by the valence electronic structure of $n\text{s}^2$. The whole electronic structure can be represented as follows: $[\text{Noble gas}]n\text{s}^2$, where Noble gas is the noble gas that precedes the given element in the periodic table, and n represents the valence shell.

Group 2 elements have 2 outer electrons in s orbital and when those 2 electrons are lost, they form cations with the charge + 2.

7.1. Occurrence and physical properties of group 2 elements

Activity 7.1

Name 1 or 2 elements of group 2 or their compounds that we commonly find in Rwanda

7.1.1. Occurrence

Group 2 elements are active metals and are found in nature in form of compounds or minerals such as: Limestone and marble for calcium, dolomite and magnesite for magnesium etc... Hence Group 2 metals must be produced from the minerals they are found in.



Limestone

7.1.2. Physical properties

Group 2 elements are all metals, solid at room temperature; they are good conductor of electricity. They have a silvery luster that soon disappears upon exposure to air. They are malleable and ductile but less than alkali metals of Group 1. Their atomic radius and their volume are smaller than those of Group 1 elements in the same period. The Table 4.1 below shows some other physical properties of Group 2 elements.

Atomic radius increases down the group due to increasing of electronic levels.

Melting and boiling temperature decreases down the group due to increasing of atomic radius.

The increasing of atomic radius explains also the decreasing of first ionization of the elements down the group. This also explains that the metallic character of the elements increases down the group.

Table 4.1: Physical properties of Group 2 elements

Element	Be	Mg	Ca	Sr	Ba
Electron structure	(He)2s ²	(Ne)3s ²	(Ar)4s ²	(Kr)5s ²	(Xe)6s ²
Atomic radius (nm)	0.11	0.16	0.20	0.21	0.22
Melting point (°C)	1280	650	838	768	714
Boiling point (°C)	2770	1110	1440	1380	1640
Density (g.cm ⁻³)	1.85	1.74	1.55	2.6	3.50
First ionisation energies	900	740	590	550	500
Electronegativity	1.57	1.31	1.00	0.95	0.89

Checking up 7.1

Question 1: Metals are reducing agents because they lose easily electrons. You are given 3 elements of Group 2: Be, Ca and Ba. Which one are you going to choose as the best reducing agent, and explain why?

Question 2: How does each of the following properties of the elements in Group 2 changes down the group and why?

- i) Atomic radius
- ii) Ionisation energy
- iii) Electronegativity

7.2. Reactivity of group 2 elements

Activities 7.2 (a)

- Pour 200cm³ of water in two different beakers
- To the first beaker, add a small piece of magnesium ribbon. To the second beaker, add a very small piece of sodium.
- Record your observation.
- Put a piece of blue and red litmus paper in both beakers
- Record your observations.

Activity 2:

- Pour 200cm³ of water in pyrex beaker or borosilicate beaker
- Heat until water boils

- Using crucible tongs, hold a large piece of magnesium in the steam
- Record your observations

Activities 7.2 (b)

Reaction of magnesium and hydrochloric acid

Experimental procedures

(1) Reaction of magnesium and hydrochloric acid

- Put 100 cm³ of 0.2M dilute HCl(aq) in a beaker. Add a small piece of magnesium ribbon.
- Record your observations
- Do not test the gas given off, it can cause the explosion.

Group 2 metals react by losing 2 electrons; they are reactive than the corresponding alkaline metals. They form ionic compounds.

Reactions	Explanations
$\text{Mg}_{(s)} + \text{O}_2 \rightarrow \text{MgO}_{(s)}$	When magnesium is burnt, there is formation of the ash which is magnesium oxide
$\text{Mg}_{(s)} + \text{Cold H}_2\text{O}_{(l)} \rightarrow \text{no reaction}$ $\text{Mg}_{(s)} + 2\text{H}_2\text{O}_{(g)} \rightarrow \text{Mg}(\text{OH})_{2(aq)} + \text{H}_2(g)$	Magnesium cannot react with cold water, but it can react with the steam.
$\text{Ca}_{(s)} + \text{Cold water}$ $\text{Ca}_{(s)} + 2\text{H}_2\text{O}_{(l)} \rightarrow \text{Ca}(\text{OH})_{2(aq)} + \text{H}_2(g)$	Calcium reacts with cold water to produce calcium hydroxide. This reaction shows that calcium is more reactive than magnesium and reactivity of group 2 elements increases as you go down the group.
$\text{Mg}_{(s)} + \text{O}_2 \rightarrow \text{MgO}_{(s)}$	When magnesium is burnt, there is formation of the ash which is magnesium oxide
<u>Reactions with Hydrogen:</u> $\text{Ca}_{(s)} + \text{H}_2(g) \rightarrow \text{CaH}_2(s)$	They react with hydrogen to produce metallic hydrides.
<u>Reactions with Oxygen:</u> $2\text{M}_{(s)} + \text{O}_2(g) \rightarrow 2\text{MO}_{(s)}$ M = Group 2 metal	They react with oxygen to produce metal oxides of formula, MO, except that in excess oxygen barium forms peroxide (BaO ₂). An oxide is a compound containing oxygen in a -2 oxidation state, O ⁻² , whereas peroxide ion is O ₂ ⁻² .
<u>Reactions with Nitrogen:</u> $3\text{M}_{(s)} + \text{N}_2(g) \rightarrow \text{M}_3\text{N}_2(s)$	These reactions cannot occur in ordinary condition; extremely high temperatures are required.
<u>Reactions with Halogens:</u> $\text{M}_{(s)} + \text{Cl}_2(g) \rightarrow \text{MCl}_2(s)$	They react with halogens to form metal halides. They all react vigorously with chlorine to produce ionic chlorides of formula MCl ₂ , except that BeCl ₂ is covalent when anhydrous.
<u>Reactions with Water:</u> $\text{M}_{(s)} + 2\text{H}_2\text{O}_{(l)} \rightarrow \text{M}(\text{OH})_{2(aq)} + \text{H}_2(g)$	Beryllium does not react with water; however, magnesium, calcium, strontium, and barium do react to form metal hydroxides and hydrogen gas.
<u>Reactions with acids:</u> $\text{Mg}_{(s)} + 2\text{HCl}_{(aq)} \rightarrow \text{MgCl}_2_{(aq)}$	All the members react with acids forming the corresponding salts and liberating hydrogen.

+H ₂ (g).	
Reaction with strong oxidizing acids $M(s)+4HNO_3(aq)\rightarrow M(NO_3)_2(aq)+2H_2O(g)+2NO_2(g)$	With the strong oxidizing acids like HNO ₃ , salt, water and oxides are obtained.

Radium is radioactive and is not considered in this section.

Checking up 7.2

1. With equations of chemical reactions, show how the following group 2 metals react:

i) Be with HCl(aq)

ii) Ca with N₂

iii) Mg with H₂O

1. Give the reason why beryllium shows different properties from the rest.

7.3. Properties of group 2 compounds

7.3.1. Ionic and covalent character of oxides and halides

Activity 7.3.1 (a)

-Pour 100 ml of paraffin in a beaker

-Put 1g of calcium chloride and try to make a solution.

-Pour 100ml of water in another beaker

-Put 1g of calcium chloride and try to make aqueous solution

-Write down your observations and comments.

Activity 7.3.1 (b)

-Place a beaker on a table

-Cut 15cm of magnesium ribbon

-Using crucible tongs, hold and burn the magnesium ribbon over the beaker.

What do you observe?

-Add some water to the ash in the beaker.

-Shake the mixture and add 2 drops of phenolphthalein or touch the mixture with a red litmus paper

-Record all your observations.

a) oxides

Group 2 (like group 1), react with oxygen to form normal oxides (containing O²⁻ion) and peroxide (containing O₂²⁻ion). The oxides are ionic dissolve in water to give solutions of hydroxide ions except BeO. Group 2 oxides are basic oxides; they react with water to produce metal hydroxides:

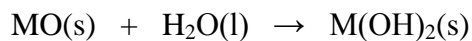

When group 2 hydroxides dissolve in water, they give alkaline solutions:

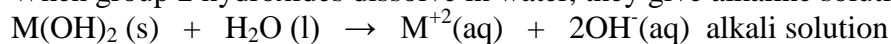

That is why Group 2 metals, as group 1 metals, are called “**alkaline earth**” metals.

Peroxides give hydrogen peroxide also: $\text{MO}_2\text{(s)} + 2\text{H}_2\text{O} \rightarrow \text{Mg(OH)}_2\text{(s)} + \text{H}_2\text{O}_2\text{(aq)}$

b) Halides

- All the halides of alkaline earth metals are *ionic* in nature except beryllium halides. Beryllium halides are generally *covalent* and soluble in organic solvents.
- Beryllium chloride is *covalent* and *hydrolyses* to form $\text{Be(OH)}_2\text{(s)}$ and HCl(aq) :
- $\text{BeCl}_2\text{(s)} + 2\text{H}_2\text{O(l)} \rightarrow \text{Be(OH)}_2\text{(s)} + 2\text{HCl(aq)}$
- **Question:** why do we call this reaction “hydrolysis”
- Magnesium chloride is intermediate, it *dissolves* and *hydrolyses slightly*.
- Other group 2 chlorides just *dissolve without hydrolysis*.

Checking up 7.3

- Write three factors that cause chlorides of group 2 to dissolve with or without hydrolysis.
- What’s a basic oxide?
- When limestone is heated at high temperature, (i) it form calcium oxide or quicklime; (ii) when water is added to quicklime, slaked lime (ishwagara) is formed. Write the chemical equation involved in (ii).

7.3.2. Trends in thermal stability of carbonates, hydroxides and nitrates

Activity 7.3.2

Procedure

- Put 2g of $\text{Ca(NO}_3)_2$ in a pyrex test tube
- Heat strongly
- Use a wet blue litmus paper to test the gas given off.
- Note your observations
- Replace $\text{Ca(NO}_3)_2$ with CaCO_3 , CaSO_4 and Na_2CO_3

Question:

Write balanced equations for reactions in the above activities.

Caution: avoid the use of barium nitrate and strontium nitrate which can explode.

Thermal stability refers to the resistance to decomposition of the compound on heating. Increased thermal stability means a higher temperature is needed to decompose the compound.

Group II metal carbonates, nitrates and hydroxides decompose to heat to give the corresponding metal oxide and release CO_2 , NO_2 and O_2 , and H_2O respectively.

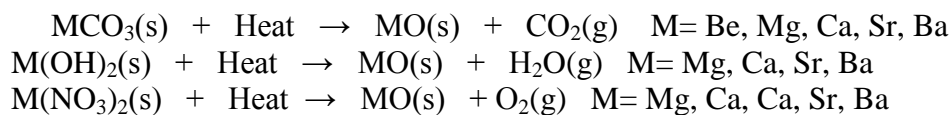

The **thermal stability increases down the group** as the ionic character of the compounds increases down the group. Compounds of metals higher in the group (smaller ionic radius) decompose more easily than compounds of metals lower in the group, due to increase in covalent character upward in the group. Compared to group 1 metals, compounds of group 2 metals are less stable to heat.

Note: The hydrogen carbonates, $\text{M}(\text{HCO}_3)_2$, only exist in solution and are very unstable. When their aqueous solutions are heated they decompose to carbonate, water and carbon dioxide:



This is the reaction that takes place when hard water (presence of $\text{Mg}(\text{HCO}_3)_2(\text{aq})$ and $\text{Ca}(\text{HCO}_3)_2(\text{aq})$) is heated.

Checking up 7.3.2

Question:

1. You have two carbonates A and B. Heated at high temperature, B decomposes and a gas evolves; on the contrary, A seems not to change. Which one corresponds to sodium carbonate and which one corresponds to calcium carbonate? Justify your answer.
2. Write the chemical equation to represent the thermal decomposition of limestone ($\text{CaCO}_3(\text{s})$) to produce carbon dioxide (quicklime).

7.3.3. Trends in solubility of hydroxides, carbonates, hydrogencarbonates and sulphates

Activity 7.3.3

You are provided with 8 test tubes .

- Put a half spatula end of each alkaline earth salt into 3ml of water, in labeled test tubes.
- No1= Magnesium hydroxide; No2= Magnesium sulphate; No3= Calcium hydroxide, No4= Calcium sulphate; No5= Strontium hydroxide; No6 = Strontium sulphate; No7= Barium hydroxide; No8= Barium sulphate.
- Shake the test tubes and try to make aqueous solution.
- Write down your observations and related comments.

The solubility of salts depends on two main opposite factors:

The energy of dissociation of the crystal: The energy change needed to dissociate the solid crystal into its ions. This process requires energy; the process is endothermic.

The energy of hydration of the ions produced: the amount of energy released when ions undergo hydration or are surrounded by water molecules; this process is exothermic.

When the combination of the two processes above is in favor of the hydration of ions, the salt is soluble; otherwise the salt is not soluble.

The solubility will increase when the hydration process predominates more and more the dissociation process and vice-versa.

a) Sulphates

Their solubility *decreases down the group*

BeSO₄ and MgSO₄ are soluble

CaSO₄ is slightly soluble

SrSO₄ and BaSO₄ are insoluble

b) Hydroxides

Their solubility **increases down the group.**

Be(OH)₂ and Mg(OH)₂ are insoluble

Ca(OH)₂ and Sr(OH)₂ are slightly soluble, and Ba(OH)₂ is fairly soluble

c) Carbonates

They are sparingly soluble in water. The carbonates of group 2 elements tend to be less soluble as you go down the group.

d) Hydrogen carbonates

The metals of group 2, magnesium, calcium, strontium, and barium form **hydrogen carbonates** compounds that contain the hydrogen carbonate anion, **HCO₃⁻**, also known as the **bicarbonate anion**. Hydrogen carbonates of the alkaline earth metal exist only in solution; they are soluble in water.

Due to the high charge of their cations that attract water molecules, group 2 salts are more hydrated than group 1 salts. That is why they are often used as drying agents.

Checking up 7.3.3

1. An aqueous solution may contain barium ion, Ba²⁺, how are you going to organize to test if that ion is or not present in your sample? Illustrate your explanation by chemical equations.
2. You are given two white solid samples A and B. The only information you have is that one of them is Be(OH)₂ and the other is Ba(OH)₂. What are you going to do to try to identify those samples?

7.4. Anomalous properties of beryllium compounds

Activity 7.4

-Give 1 or 2 examples showing an abnormal behavior of beryllium compared to the other members of the group?

-What do you think may cause that anomaly?

Beryllium shows the uniqueness in its group. Beryllium has higher tendency of forming complexes compared to other group 2 elements.

- Beryllium ion, Be^{2+} , is *very small compared* to other group 2 metal ions.
- Beryllium has *a high electronegativity compared with the rest of Group 2*, hence it forms compounds with more covalent characters.
- For an ionic bond to form, beryllium must give up its electrons, but it is too electronegative to do so.

The uniqueness of Beryllium makes its compounds to show anomalous properties. For example:

1. **Beryllium hydroxide, $\text{Be}(\text{OH})_2$** is *amphoteric* whereas the other group 2 hydroxides are basic. An amphoteric substance behaves as an acid when it reacts with a base, and as a base when it reacts with an acid:

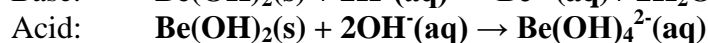

2. **Beryllium chloride, BeCl_2** , is *soluble in non-polar organic solvents*, whereas the other group 2 chlorides are ionic and dissolve in water (the polar solvent). This fact illustrates the covalent character of beryllium compounds.

3. **Beryllium complexes.** It forms complexes ions such as $[\text{Be}(\text{OH})_4]^{2-}$ and $[\text{BeCl}_4]^{2-}$.

Checking up 7.4

Complete the table concerning the compounds of beryllium.

Compound	Reagents or solvent	Observation & Equations (if any)
$\text{Be}(\text{OH})_2$	HCl	
$\text{Be}(\text{OH})_2$	NaOH	
BeCl_2	Non polar solvent	

7.5. Identification test for Ba^{2+} ions in aqueous solutions

Activity 7.5

Task 1:

- Pour 100ml of distilled water into the beaker 1
- Add 1g of Beryllium nitrate
- Stir to make the aqueous solution

-Repeat the procedure, by replacing Beryllium nitrate by nitrates of other group 2 elements(Mg;Ca;Sr;Ba).

- Use a nichrome wire or magnesia rod to put each compound in a Bunsen flame.

-Write down your observations and related comments.

Task 2

-Put 3ml of barium nitrate (Prepared also for task 1) in a test tube

-Add 10 drops of dilute $\text{HNO}_3(\text{aq})$

-Using a dropper, add 10 drops of sodium sulphate solution.

-Write down your observation and the ionic equation.

a) Formation of precipitate

The insolubility of **barium sulphate** is the basis of a test for barium ions in solution. If a few drops of a solution containing sulphate ions, SO_4^{2-} (CaSO_4 , Na_2SO_4 , etc.) are added to a solution containing barium ions, a **white precipitate** of *barium sulphate* insoluble in acidic solution will form.



b) Flame test

Like the compounds of group 1 metals, calcium, strontium and barium produce coloured flames when their compounds are put in a Bunsen flame.

Element	Beryllium	Magnesium	Calcium	Strontium	Barium
Colour of the flame	Colorless/brightwhite	Colorless/verybright white	Brick red	Crimson red	Apple green



Calcium



Magnesium

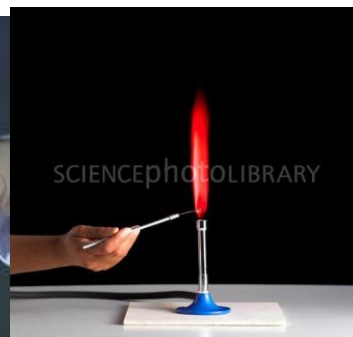

Strontium



Barium

Beryllium

Checking up 7.5

Question: By accident, a child drinks a solution of barium chloride.

-How can a physician proceed in order to precipitate Ba^{2+} into the patient's stomach?

-What is the needed ion for this treatment?

-You have two unknown samples containing Ca^{+2} and Ba^{+2} ions respectively. You need to identify them. Suggest two different methods you can use and explain.

7.6. Uses of group 2 elements and their compounds

Activity 7.6

Describe the following compounds and show how each compound can be used to prepare another if possible.

a) Limestone b) Quicklime c) Slaked lime

b) Have you heard about soil amendment in Rwanda? What is it?

1. Beryllium

Because beryllium is relatively light and has a wide temperature range, it can be used in the manufacture of aircrafts' components.

2. Magnesium

- Chlorophyll, the pigment that absorbs light in plants, is a complex of magnesium and is necessary for photosynthesis.
- Magnesium hydroxide is used as Anti-acid medicine
- Magnesium is used in making Grignard reagents, the organomagnesium compounds.
- Magnesium is used as sacrificial anode to prevent iron from rusting.
- Salts of magnesium and calcium are used in chemistry laboratory as drying agents.

3. Calcium

- Calcium is the major component of Limestone, raw material for manufacturing cement and slaked lime.
- One of the important materials involving calcium is plaster of Paris, which gets its name because a major ingredient (gypsum), $\text{CaSO}_4 \cdot n\text{H}_2\text{O}$, was mined near Paris. Plaster of Paris

is used in making casts for broken bones, but it is also used for sculptures and plasterboard walls. Gypsum is used in the manufacture of cement.

- Calcium carbonate is used in the extraction of iron, manufacture of tiles, plates, laboratory mortar and pestle, in agriculture to reduce the acidity of soil.

4. The process of making slaked lime from limestone

Limestone is a naturally occurring material composed mainly by calcium carbonate. Limestone is used to produce quicklime and slaked lime (ishwagara):

a) Steps

First step: Decomposition of limestone by heating, a process called calcinations, giving quicklime.

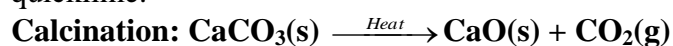

Quicklime

Calcination is carried out in a high-temperature kiln (about 1000°C) with continuous removal of CO₂ (g) to promote the forward reaction. The product formed, CaO(s), is called lime or quicklime.

Second step: Hydration of quicklime giving Slaked lime

In the process of hydration, the reaction of quicklime with water produces Ca(OH)₂(s) known as slaked lime.

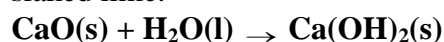

Slaked lime

b) Uses of limestone and slaked lime

- Some limestone is used as building stones.
- However, most limestone is used to manufacture other building materials.
- Limestone is the raw material for the manufacture of cement (see Production of Cement in Rwanda at Bugarama Cement Factory).
- Slaked lime, Ca(OH)₂, is the cheapest commercial base and is used in all applications where high water solubility is not essential.
- Quicklime appears in the process used for manufacturing cement and is the cheapest form of alkali.
- Quicklime is used in the manufacture of sodium carbonate from caustic soda.
- Calcium carbonate and slaked lime are used to decrease soil acidity and acidity in lakes which are acid polluted.

5. Manufacture of cement

Cement is an important building material. It was first introduced in England in 1824 by *Joseph Aspdin*. Some types of cement are called Portland cement because it resembles with the natural limestone quarried in the Isle of Portland, England.

Cement is a product obtained by combining a material rich in lime, CaO, such as limestone, with other material such as clay which contains silica, SiO₂ along with the oxides of aluminium, iron and magnesium.

The raw materials for the manufacture of cement are **limestone** and **clay**. When clay and limestone are strongly heated together they fuse and react to form '**cement clinker**'. This clinker is mixed with 2-3% by weight of gypsum (CaSO₄·2H₂O) to form **cement**.

Environmental risks: during the process of producing cement and quicklime, gases, mainly carbon dioxide, and solid particles are sent in air and constitute an environmental risk if their concentration increases in the atmosphere. All measures must be taken to avoid that those gases and solid particles become an real environmental problem.

6. Strontium

- It is used in fireworks as it produces a scarlet flame color.
- Strontium chloride (SrCl₂) is used to make toothpaste for sensitive teeth.

Checking up 7.6

1. Name any two compounds of calcium and in each case give two uses of each.
2. Describe how slaked lime can be obtained from limestone.
3. The elements Be, Mg and Ba belong to Group 2 in the periodic table. How do they react with water and NaOH?

7.7. End unit assessment

1. Which of the following is NOT an alkaline earth metal? (a) Ba (b) K (c) Mg (d) Be (e) Ra
2. True or False: group 2 metals do not react vigorously with water.
3. Which alkaline earth metal is a main component in our bones?
4. Which group 2 metal has the highest ionization energy? And why?
5. Which element has the lowest melting point? (a) Ba (b) Ra (c) Ca (d) Mg
6. Why is the term alkaline earth used to describe the Group 2 elements?
7. Identify what is observed when the flame test is carried out for group 2 elements?.
8. Explain why all alkaline earth metals form ions by losing 2 electrons?
9. Which Group 2 element is radioactive?
10. Which substance is acting as the reducing agent in the reaction below?
$$\text{Be}(s) + \text{F}_2 \rightarrow \text{BeF}_2$$
 Explain
- 11 .a) How do each of the following properties of the elements in group 2 change with increasing atomic number?
 - i) Atomic radius
 - ii) Ionization energy
 - iii) Strength as reducing agents
 - iv) Vigour of reaction with chlorine
 - v) Electropositivityb) In each case, explain why the property changes in the way you have suggested.

12. Group 2 contains the elements Be; Mg; Ca; Sr; Ba.

- a) Are those elements metals or non metals? Give one reason for your answer.
- b) What ion or ions are formed by calcium?
- c) Explain why it is not possible to find a compound with Mg^+
- d) Group 2 elements form hydrated salts, while the corresponding compounds of group 1 elements are anhydrous. Suggest reasons for this difference.

13) The elements in group 2 of the periodic table are barium, beryllium, calcium, magnesium and strontium.

- a) Why do all the metals in group 2 have an oxidation number of +2 ?
- b) Why do the elements in group 2 not have an oxidation number of +1 and +3
- c) Write an equation to illustrate the process occurring when the second ionization energy of magnesium is measured.

UNIT 8: TRENDS OF CHEMICAL PROPERTIES OF GROUP 13 ELEMENTS AND THEIR COMPOUNDS

Key unit competence: Compare and contrast the chemical properties of the Group 13 elements and their compounds, in relation to their position in the Periodic Table.

Learning objectives

By the end of this unit, I will be able to:

- State the physical properties of Group 13 elements
- Explain the reactivity of Group 13 elements with oxygen, water, halogens, dilute acids and sodium hydroxide
- Describe the properties of oxides, hydroxides and chlorides of Group 13 elements
- State the uses of Group 13 elements and their compounds
- Compare and contrast the reactivity of Group 13 elements with oxygen, water, halogens, dilute acids and sodium hydroxides
- Perform experiments to show the solubility of Group 13 compounds
- Practically illustrate the amphoteric properties of aluminium oxides and hydroxides
- Identify the anomalous properties of boron and its compounds
- Perform chemical tests for the presence of aluminium ion in the solution.

8.1. Physical properties of group 13 elements

Activity 8.1

(1). Consider the following elements: boron ($z=5$), aluminium ($z=13$), gallium ($z=31$), indium ($z=49$), thallium ($z=81$)

(a) Write the electronic configuration of each element in term of s,p,d,f orbitals.

(b) State the period and the block to which each element belongs.

(2). Draw diagram to show metallic bond in aluminium metal.

(3). Cite one known application of an element of Group 13 in our everyday life

(4). Explain why aluminium is better conductor of electricity than sodium

(5). In groups learners make research in library or on internet, discuss and explain why

(a) Group 13 elements have higher melting point than group 1 and 2 elements.

(b) Boron has higher ionization energy than other element of the same group.

The elements of group 13 of the periodic table are boron (${}^5\text{B}$), aluminium (${}^{13}\text{Al}$), gallium (${}^{31}\text{Ga}$), indium (${}^{49}\text{In}$), and thallium (${}^{81}\text{Tl}$). Group 13 elements have a general outermost electronic configuration of $ns^2 np^1$. This group marks the beginning of the p-block elements. It is sometimes called the Boron group.

With the exception of boron, group 13 elements are metals. Boron is a non-metal element with high melting point and low density.

Aluminium is a metal element and has a low density, it is a good conductor of heat and electricity, shiny, malleable, ductile and it has higher melting point than groups 1 and 2 metals due to strong metallic bond resulting from 3 valency electrons involved in making metallic bonding in aluminium metal.

In small atoms electrons are held tightly and are difficult to remove, while in large ones they are less tightly held since they are far away from the nucleus and are easy to remove so that the ionization energy decreases down the group as the atomic radius increases.

The greater the forces of attraction and hence the boiling point and melting point decrease down the group as the atomic radius increases.

Table1: Physical properties of Group 13 elements

Element	Atomic No.	Group	Period	Nature	Melting points (°C)	Van der Waals/atomic radius (pm)	Pauli electronegativity (EN)	1st ionization energy (KJmol ⁻¹)
B	3	13	2	Non-metal	3927	88	2.0	801
Al	13		3	Metal	2447	126	1.5	578
Ga	31		4	Metal	2237	126	1.6	580
In	49		5	Metal	2047	150	1.7	560
Tl	81		6	Metal	1467	155	1.8	590

Checking up 8.1

- Write the electronic structure of Al(Z=13).
 - Write the equation that shows how aluminium forms its ion.
 - Explain why aluminium forms Al³⁺ ion instead of Al¹⁺
- Explain the cause of the strong bond in aluminium metal
- Within the elements of group 13 elements down the group give and explain the relationship between atomic radius and:
 - the boiling point
 - ionization energy
- The following table shows 3 unknown group 13 elements A,B,C and some of their physical properties. Predict among the group 13 elements (Al,B,Tl), which one should correspond to A,B,C. Justify your answer

Element	Melting points (°C)	van der waals/atomic radius (pm)	1 st ionization energy (kJmol ⁻¹)
A	1467	155	590
B	3928	88	801
C	2447	126	570

- Match the element in column A to the corresponding atomic radius in column B. Justify your answer

COLUMN A (ELEMENT)	COLUMN B (ATOMIC RADIUS)
1.Thallium	a.155
2.Boron	b.88
3.Gallium	c.126

8.3. Reaction of aluminium

8.3.1. Reaction of aluminium with oxygen

Activity 8.3(a)

In groups learners make research, discuss and explain the following statement:

- (a) aluminium is a metal therefore it forms compounds with the covalent character.
 (b) aluminium forms amphoteric oxide.

Activity 8.3 (b)

Experiment: burning an aluminium metal in air/oxygen and amphoteric properties of Al_2O_3

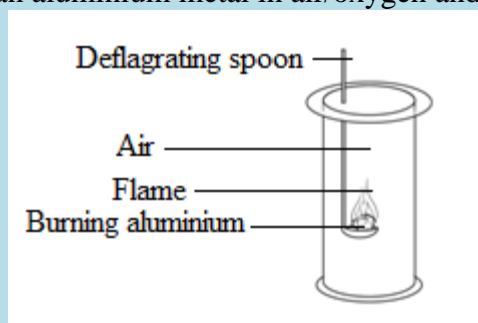

Apparatuses: deflagrating spoon, Bunsen burner, glass beaker.

Chemicals: aluminium sheet, hydrochloric acid, sodium hydroxide

Other requirements: match box and petroleum gas

Procedure:

1. Cut a small piece of aluminium
2. Place it on a deflagrating spoon and heat it in a non-luminous flame
3. When combustion is complete, divide the solid residue into two portions and place each portion in two different glass test tubes
4. Add 10ml solution of HCl To the first test tube and 10 ml of NaOH to the second test tube. Observe

Study questions

- a) Write the equations of reactions that take place when aluminium metal is burnt in air
- b) Name the product that was formed.
- c) Write the equations of reaction between the product in (b) with HCl and with NaOH

Aluminium burns in oxygen to form aluminium oxide

-In its compounds, Aluminum occurs exclusively in the +3 oxidation state. It rapidly reacts with oxygen in air to give water in soluble coating of Al_2O_3 . This oxide layer protects the metal beneath from further corrosion.

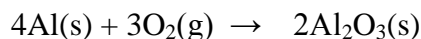

-All other Group 13 elements also produce compounds of the formula M_2O_3 :



Aluminum, gallium, and indium has +3 as the most stable oxidation state, whereas thallium has +1 oxidation state as the most stable.

At high temperatures, thallium also reacts with oxygen to produce Tl_2O :

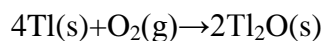

The most common oxide form of boron, B_2O_3 or boron trioxide, is obtained by heating boric acid:



8.3.2. Reactions with acids

Activity 8.3 (c)

Reaction of aluminium with acids

Experiment

Learners perform experiments to investigate the reaction of aluminium with moderately concentrated HCl on warming and concentrated H_2SO_4

Apparatuses: Bunsen burner, gas jar, thistle, water bath, delivery tube, wooden splint

Chemicals: aluminum sheet, concentrated hydrochloric acid concentrated H_2SO_4 , solution of KMnO_4 .

Other requirements: match box and petroleum gas

Procedure:

Put aluminium powder into two different flat bottomed flasks and connect on each a thistle, delivery tube as shown on the figure A and B.

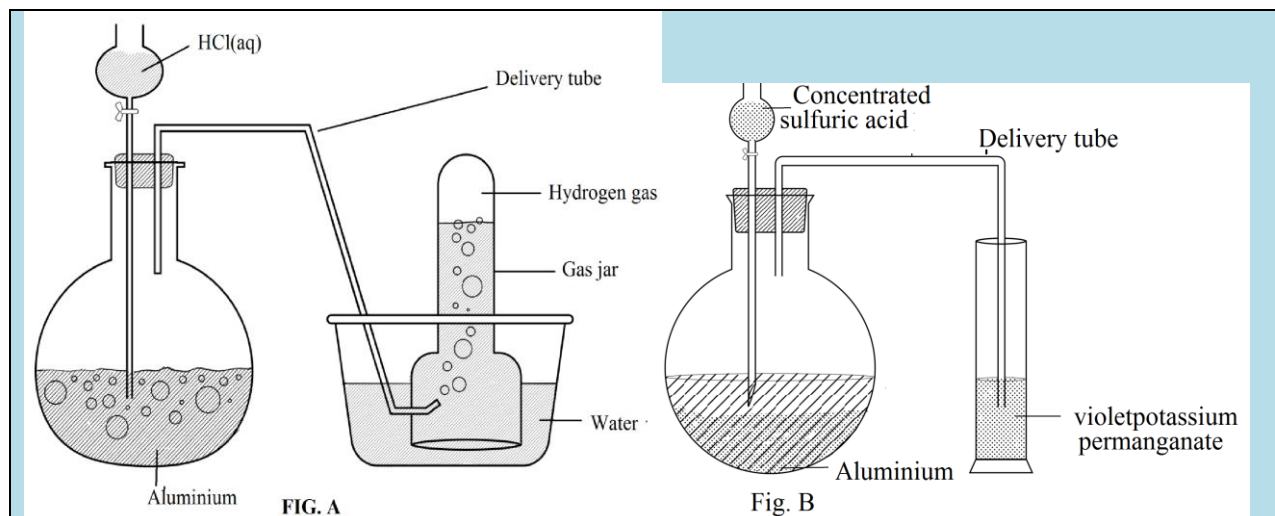

(a) Pour in the thistle of the apparatus A moderately concentrated HCl open the tap of the thistle and let HCl flow on Aluminium powder in the flat bottomed flask

Collect the gas evolved and test the gas using a burning wooden splint.

(b) Pour in the thistle of the apparatus B concentrated H_2SO_4 , open the tap of the thistle and let H_2SO_4 flow on Aluminium powder in the flat bottomed flask

Collect the gas evolved and test the gas using a violet solution of KMnO_4 .

Study Questions

(a) write the equations of reaction when aluminium reacts with:

(i) moderately concentrated HCl

(ii) concentrated H_2SO_4

(b) From your observations, explain the chemical test described for the gas evolved in each case, illustrate by chemical equations if any.

- **Reaction with HCl**

Aluminium reacts when warmed with moderately concentrated hydrochloric acid forming aluminium chloride and hydrogen gas:

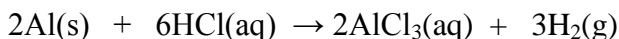

Hydrogen is tested using a burning splint. A pop sound is heard during the test.

- **Reaction with H_2SO_4**

Aluminium does not react with dilute sulphuric acid but reacts with concentrated sulphuric acid forming aluminium sulphate, sulphur dioxide and water:



Sulphur dioxide gas is tested using a violet solution of potassium manganate(VII) that decolorizes to give colorless $\text{Mn}^{2+}(\text{aq})$ ion

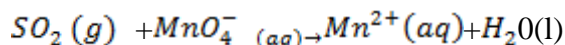

Note: Aluminium does not react with HNO_3 because of the insoluble layer of Al_2O_3 formed which prevents further reaction.

8.3.3. Reaction with alkalis

Activity 8.3 (d): Reaction of aluminium with concentrated NaOH solution

Experiment

Learners perform experiments to investigate the reaction of aluminium with NaOH solution

Apparatuses: thermometer, pyrex beaker, stirrer

Chemicals: aluminium powder, 40% sodium hydroxide solution

Procedure:

-Prepare 40% of sodium hydroxide by mixing 60cm^3 of water with 40g of sodium hydroxide

-Take 0.5 g of aluminium powder into a pyrex beaker

- Pour the solution of sodium hydroxide in the pyrex beaker containing aluminium powder and allow the reaction to proceed for about 5 minutes.

-Use thermometer to record the temperature during the process

Aluminium reacts vigorously with sodium hydroxide solution forming sodium aluminate and hydrogen gas.

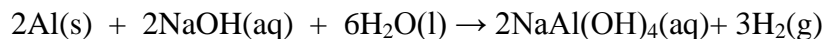

8.3.4. Reaction with halogens

Activity 8.3.4

(a) In terms of s,p,d,f orbitals give the electronic structure of aluminium (Z=13)

(b) How many valency electrons does aluminium possess? Explain how you reach this conclusion (c) Give the formula of the compound formed between aluminium and chlorine (Z=17)

d) Explain why the compound $AlCl$ is not formed

- Aluminium fluoride is made by direct combination of the metal with fluorine.

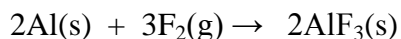

- Aluminium chloride is made by passing chlorine gas over heated aluminium metal

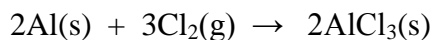

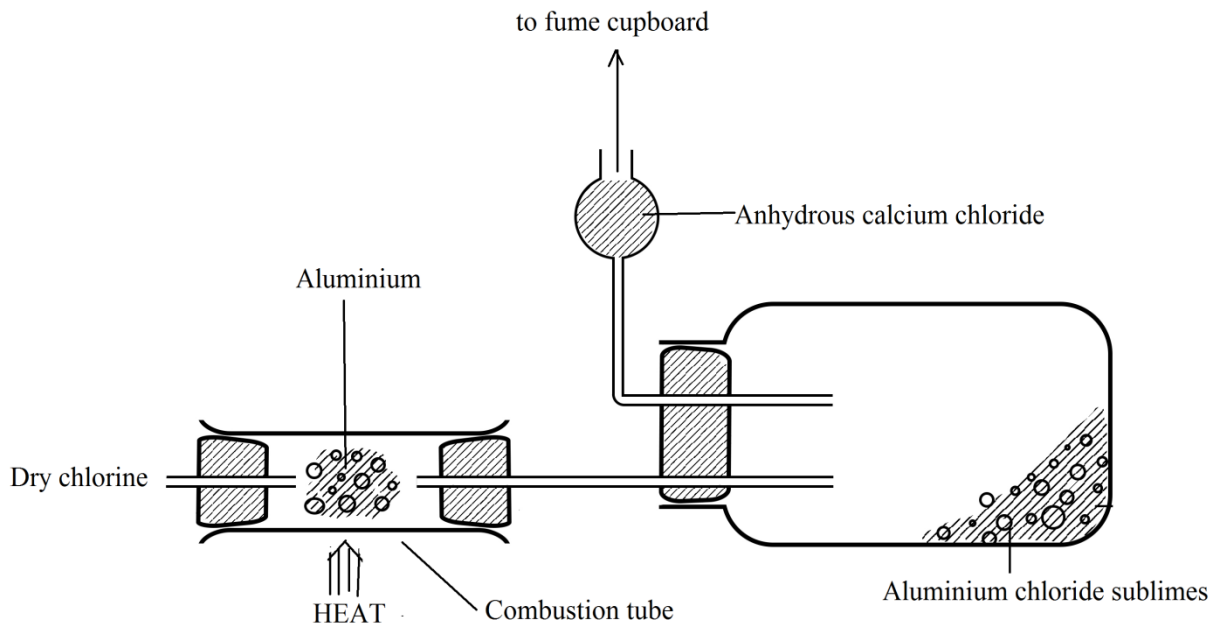

Aluminium can be reacted with moderately concentrated HCl

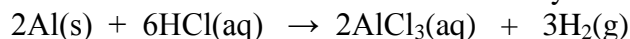

Al, Ga, In and Tl react with halogens to give binary halides of formula EX_3 . In this case, all 3 valence electrons are used in the reaction. All trihalides of group 13 elements are known except Tl(III) iodide, because iodine is a weak oxidizing agent.

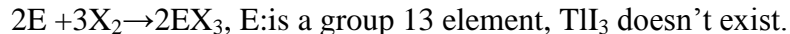

Fluorides are ionic and have high melting points due to the small size of fluoride ion.

For the same halide ion bonded to group 13 element the ionic character increases down the group as the size of cation of group element increases. For example AlCl_3 is more covalent than TlCl_3 .

For the same element of group 13 the covalent character increases with increasing size of the anion. For example GaCl_3 is ionic while GaI_3 is covalent

The chemistry of gallium is similar to that of aluminium.

The chemistry of indium is similar to that of aluminium and gallium except that compounds containing the 1+ ion are known, such as InCl and In_2O , in addition to those with more common 3+ ions.

The chemistry of thallium is completely metallic. For example, Tl_2O_3 is a basic oxide. Both the +1 and +3 oxidation states are quite common for thallium; Tl_2O_3 and TlCl_3 and TlCl are all well-known compounds.

The tendency for heavier members of group 13 to exhibit the +1 as well as the expected +3 oxidation states results from an effect called “**inert pair effect**”.

In this effect, since s electrons are closer and more attracted by the nucleus down the group, they are less and less available to participate in bond formation hence the compounds; only p electron will participate, hence the oxidation state +1.

For lighter members such as Al the s and p valency electrons are always available and used at the same time to form compounds where they are in oxidation state +3.

Checking up 8.3

1. Using chemical reactions differentiate and explain the action of HCl, H₂SO₄ and HNO₃ on aluminium metal.
2. In the groups learners discuss and explain the following statement: aluminium utensils are not washed in strong alkaline solutions.
3. Write and balance the equation of reaction between
 - a) Aluminium and bromine
 - b) Gallium and chlorine
 - c) Gallium and hydrochloric acid
 - d) If b) and c) above give different products, explain why.
 - e) Indium and iodine

8.4. Oxides and hydroxides of group 13 elements

Activity 8.4

Write chemical reactions to illustrate the amphoteric character of aluminium hydroxide.

Aluminium oxide is amphoteric:

- it dissolves in mineral acids to form aluminium salts: in this case it acts as a base.
$$\text{Al}_2\text{O}_3(\text{s}) + 6\text{H}^+(\text{aq}) \rightarrow 2\text{Al}^{3+}(\text{aq}) + 3\text{H}_2\text{O}(\text{l})$$
- it dissolves in caustic alkali to form aluminate: in this case it acts as an acid.
$$\text{Al}_2\text{O}_3(\text{aq}) + 2\text{OH}^-(\text{aq}) + 3\text{H}_2\text{O}(\text{l}) \rightarrow 2[\text{Al}(\text{OH})_4]^-(\text{aq})$$

Aluminium hydroxide also shows amphoteric properties.

Checking up 8.4

- a) What is meant by amphoteric compounds? Illustrate your answer using aluminium oxide and gallium oxide
- b) Explain the concept of amphoterism using aluminium hydroxide

8.5. Anomalous properties of boron

Activity 8.5

In groups learners make research on internet and in library, discuss and explain the following statement:

- Boron is a bad conductor of electricity
- Boron has higher boiling and melting points than other member of the group
- Boron oxide is an acidic oxide

Boron – the first member of group 13 shows anomalous behavior due to the small size and high nuclear charge/size ratio, high electronegativity. This makes boron typically non-metal whereas the other members of the group are metals. Hereafter are some other anomalies.

The melting point and boiling points of boron are much higher than those of other elements of group 13.

Boron forms only covalent compounds whereas aluminum and other elements of group 13 form even some ionic compounds. The oxide of boron is acidic in nature whereas those of others are amphoteric and basic.

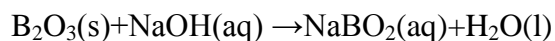

The trihalides of boron (BX_3) exist as monomers. The reason being that due to its small size, it cannot accommodate 4 large sized halogens atoms around it.

The hydrides of boron i.e. boranes are quite stable and are formed by many molecules such as diborane (B_2H_6), triboranes (B_3H_8)... while those of aluminum are unstable.

Dilute acids have no action on boron; other group 13 elements are dissolved in acids to liberate H_2 . Borates are more stable than aluminates. Boron does not decompose steam water while other members do so.

Boron combines with metals to give borides e.g. Mg_3B_2 . Other members form simply alloys.

Concentrated nitric acid oxidizes boron to boric acid but no such action is noticed with other group members.

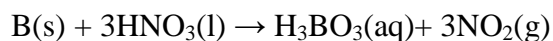

Checking up 8.5

- What is the cause of abnormal behavior of boron
- State any anomalous properties of boron

8.6. Identification of Al^{3+} ion in solution

Activity 8.6

In group of 6 learners perform experiment to test for the presence of Al^{3+} in solution:

Apparatuses: beaker, test tubes, droppers, test tube rack

Chemicals: aluminum salt solution, sodium hydroxide, ammonia solution

Procedure:

-Pour about 2cm^3 of a solution of aluminium salt into 2 different test tubes

-To 2cm^3 of solution of aluminium salt in the first test tube add drop by drop a solution of sodium hydroxide until excess. Then observe what happens.

-In a second test tube, to a 2cm^3 of aluminium salt add drop by drop a solution of ammonia until excess and observe.

Study question

Make a report on your findings and explain what happened

Aqueous solution of aluminium salt when reacted with a solution of sodium hydroxide, a white precipitate of $\text{Al}(\text{OH})_3$ is formed. $\text{Al}(\text{OH})_3$ precipitate dissolves in excess of sodium hydroxide as soluble $\text{Al}(\text{OH})_4^-$ complex ion:

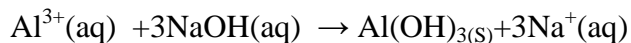

White precipitate

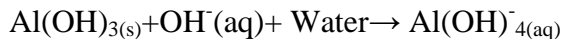

Transparent and colorless solution

When reacted with a solution of ammonia, aluminium ion Al^{3+} produces a white precipitate of $\text{Al}(\text{OH})_3$ insoluble in excess ammonia solution

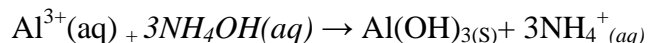

$\text{Al}(\text{OH})_3(\text{s}) + \text{excess ammonia} \rightarrow \text{no observable change}$

Checking up 8.6

State the reagent that should be used to distinguish between a solution containing aluminium chloride salt and that containing calcium chloride salt. Illustrate your answer by chemical equations and expected observations.

8.7. Uses of some group 13 elements

Activity 8.7

- Teacher brainstorms learners and ask them to talk about different applications of aluminium and its compounds in daily life.
- Make research in libraries / internet and discuss about the use of aluminium, boron and gallium and make presentations of your findings.

Aluminium

Aluminium is abundant in the Earth's crust and its applications are many and varied; hereafter some of those applications and uses; it is:

- used in making cooking utensils: this is because of its bright appearance and lightness, resistance to corrosion, and its thermal conductivity
- used as window frames or doors in buildings and houses
- used as overhead high tension cables for distribution of electricity: this is because of its low density and very good electrical conductivity.
- used in alloys (e.g. Al and Mg) for the construction of airplanes and small boats due to its lightness, malleability and higher tensile strength in the alloy.
- Being completely resistant to corrosion it is ideal for packaging food
- The insulating property of aluminium arises from its ability to reflect radiant heat; this property is used in firefighters' wear to reflect the heat from the fire and keep them cool.
- The polished surface of aluminium is used in the reflectors of car headlights
- Aluminium is a component of clay (ibumba) used in the manufacture of cement and clay pots (ikibindi).

Boron

Applications of boron are found in:

- control rods to keep nuclear reactions in balance and avoid explosion; boron absorbs therefore excess neutrons preventing them from bombarding many uranium atoms which may result into explosion (fuel of nuclear reactors)
- the manufacture of hard boron steel
- as an additive to semiconductors silicon and germanium
- the manufacture of borosilicate glass used in vacuum flasks

Gallium

Gallium is used as a semiconductor, e.g: with phosphorus and arsenic in light emitting diodes.

Note that sodium tetrahydridoborate (III), NaBH_4 , and lithium tetrahydridoaluminate(III), LiAlH_4 , are used as reducing agents in organic chemistry.

Checking up 8.7

1. Give reasons why aluminium is used in manufacture of airplanes and cooking utensils
2. Which advices should you give to an engineer in construction who is suggesting you to use chemistry laboratory sinks made up of aluminium?

8.8. End unit assessment

1. Aluminium chloride can be prepared in the laboratory by the reaction between aluminium and chlorine using the apparatus shown below

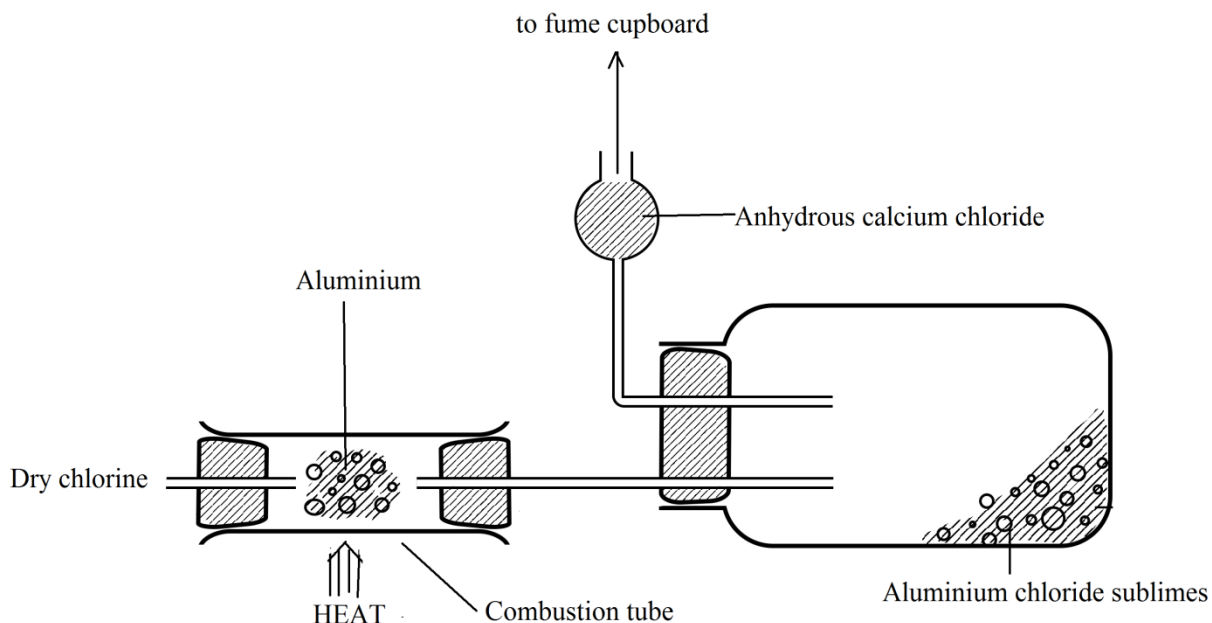

- (a) Write a chemical equation to represent the reaction.
 - (b) Why is it necessary to dry the chlorine?
 - (c) What is the purpose of the soda lime?
 - (d) Aluminium chloride is dissolved in water. Write the equation for the reaction that takes place
2. (a) With reference to aluminium oxide, explain the term amphoteric oxide. Write equations to illustrate.
(b) Explain with chemical equations why aluminium utensils are not washed in strong alkaline solutions.
 3. If you need to prepare aluminium hydroxide, why is it better to add a solution of ammonia to a solution of aluminium salt, rather than to add a solution of sodium hydroxide.
 4. How does gallium react with:

- (a) hydrochloric acid
- (b) Sodium hydroxide

5. Explain why aluminium is suitable for the following uses:

- (a) Manufacture of window frames
- (b) Electrical wiring
- (c) Packaging food
- (d) Suits for firefighters

6. Water is suspected to contain calcium and aluminium ions. State a chemical test that should be used to confirm the presence of the suspected ions. State the reagent, observations and related chemical equation if any.

UNIT 9: TRENDS IN CHEMICAL PROPERTIES OF GROUP 14 ELEMENTS AND THEIR COMPOUNDS

Key unit Competence

To be able to compare and contrast the chemical properties of the Group 14 elements and their compounds in relation to their position in the Periodic Table.

Learning objectives

By the end of this unit, I will be able to:

- Compare and contrast the physical properties of Group 14 elements.
- Compare the relative stabilities of the higher and lower oxidation states in oxides.
- Distinguish between the chemical reactions of the oxides and chlorides of Group 14 elements.
- Explain the trends in thermal stability of the oxide, halides and hydrides of Group 14 elements.
- Explain the variation in stability of oxidation state of +2 and +4 down the Group 14 elements.
- Define the diagonal relationship.

Introductory Activity 9

1. State any element of group 14 that is found in Rwanda. Where is (are) it(they) produced? What is (are) it (they) used for?

Carbon, Tin and Lead are elements of group 14:

2. State 2 allotropes of carbon and give a brief description of the structure of the two allotropes.

3. Explain the variation in electronegativity of group 13 elements as you move down a group, give examples of (compare beryllium and aluminium).

4. Discuss the way the variation in size of atoms down a group affects their:

- a) Metallic character
- b) First ionization energy
- c) Ability to form ionic or covalent compounds.

4. Describe the variation in melting points down group 14 from lithium to potassium.

9.1. Physical properties of group 14 elements.

Group 14 elements are carbon (${}^6\text{C}$), silicon (${}^{14}\text{Si}$), germanium (${}^{32}\text{Ge}$), tin (${}^{50}\text{Sn}$) and lead (${}^{82}\text{Pb}$). The elements of group 14 have one important feature in common, **each of them has four valence electrons**. They are characterized by the electronic configuration of 4 electrons in the outermost shell (ns^2np^2). The group is also called carbon family.

Group 14 elements show the clearest trend from **non-metal** to **metal character** downward the group from **carbon** to **lead**.

Carbon is a non-metal, silicon and germanium are metalloids, tin and lead are metals.

In group 14 of the periodic table, there is a considerably greater change in physical properties from top to bottom in the group than there is for example, in the alkali metals of group 1 on the left and the halogens of group 17 on the right.

Carbon is a **typical non-metal** element, silicon and germanium are **semi-metals** but tin and lead are **metals**. However, the elements of group 14 have one important feature in common, namely each of them has four valence electrons.

In the compounds of carbon, it almost invariably completes the valence shell by forming four covalent bonds, which have a tetrahedral arrangement around the carbon atom.

Silicon and germanium also usually form four covalent bonds with a tetrahedral arrangement.

Tin and lead, which are larger in volume have smaller ionization energies than carbon and silicon, and they often lose just two of their valence electrons to form the Sn^{2+} and Pb^{2+} ions.

Activity 9.1

- 1) Write the electronic configuration of carbon, silicon and tin in terms of s, p, d and f notation.
- 2) Indicate 2 uses of carbon and lead in daily use.
- 3) Explain how carbon forms 4 bonds in its compounds, eg in CO_2 .
- 4) Write the chemical formula of:
 - a) 2 inorganic compounds of carbon
 - b) 2 organic compounds of carbon.

Table 9.1: Physical properties of Group 14 elements

Property	Carbon	Silicon	Germanium	Tin	Lead
Valency shell electron configuration	$[\text{He}]2s^22p^2$	$[\text{Ne}]3s^23p^2$	$[\text{Ar}]4s^24p^2$	$[\text{Kr}]5s^25p^2$	$[\text{Xe}]6s^26p^2$
Melting point, $^{\circ}\text{C}$	3730 (Graphite)	1410	937	232	327

	3550 (diamond)				
Boiling point, °C At 1atmosphere	-	2680	2830	2270	1730
Density, g/cm ³	diamond 3.514 graphite 2.255	2.33	5.32	7.30	11.44
Atomic radius (nm)	0.077	0.117	0.122	0.141	0.154
Electronegativity (Pauling scale)	2.0	1.5	1.6	1.7	1.8
Electrical conductivity	Fairly-good conductor (graphite) Non- conductor (diamond)	Semi- conductor	Semi- conductor	Good- conductor	Good- conductor

- In graphite allotrope of carbon, each carbon is bonded to 3 other carbon atoms to form an hexagonal structure. The structure of graphite is made of hexagonal layers which are attracted to each other by weak **van der Waals forces** such that the layers slide over each other to make the structure soft(Fig.9.1).
- In diamond, each carbon is covalently bonded to 4 other carbon atoms forming a giant tetrahedral structure that makes it to be very hard (Fig.9.1).
- As you move down the group in the carbon family, the atomic radius and ionic radius increase while the electronegativity and ionization energy decrease.
- Atomic size increases on moving down the group due to additional electronic shells.
- Density increases as you move down the group.
- Carbon is the only element in the family that can be found in pure form in nature,as diamond and graphite.

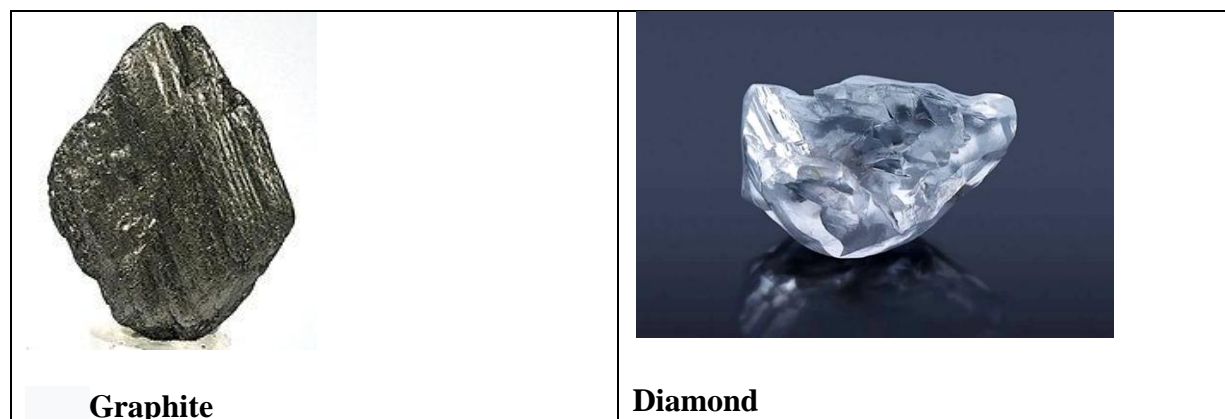

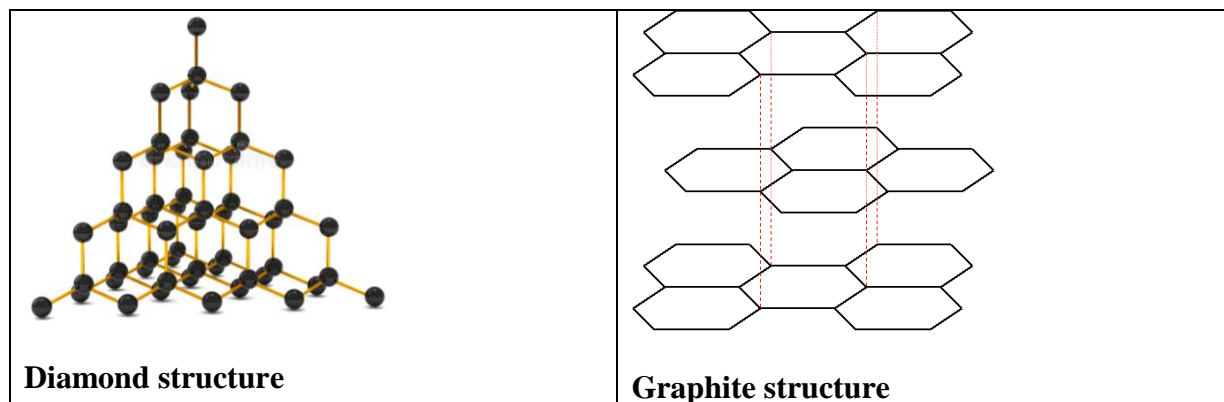

Figure 9.1: Structures of diamond and graphite

- Lead is the only element of group 14 that does not exist in various allotropes.
- Tin occurs as white, grey and rhombic tin.
- Group 14 elements have much higher melting points and boiling points than the group 13 elements.
- Melting and boiling points tend to decrease as you move down the group mainly because:
- Inter atomic bonding between the larger atoms reduce in strength as you move down the group.

Moving down the group, there is an increase in atomic size which results in less attraction of valence electrons by the nucleus. This change results in weaker metallic bonding down the group and therefore there is a **decrease** in melting point, boiling point, enthalpy change of atomization and first ionization energy.

The decrease in first ionization energy from silicon to lead is relatively little compared to that from carbon to silicon because there is a large increase in nuclear charge which counterbalances the increase in atomic radius from silicon to lead.

ii) The increase in metallic character down the group causes a general increase in conductivity.

Carbon is typically a **solid, non-metal**. Carbon graphite is a non-metal but conducts **electricity** due to delocalized electrons in its structure.

In its compounds, carbon almost invariably completes its valence shell by forming four covalent bonds, which have a tetrahedral arrangement around the carbon atom.

Silicon is solid at room temperature and pressure, it is a semi-metallic element and semi-conductor of electricity which is the second most abundant element on earth, after oxygen.



Figure 9.2: Sand which contains silicon dioxide (SiO_2)

Germanium is solid at room temperature and pressure which usually forms four covalent bonds with a tetrahedral arrangement. Germanium, is a hard, brittle, greyish-white and crystalline semi-metallic element which is a semi-conductor of electricity.

Tin is a silver-white solid metal that conducts electricity at room temperature and pressure. At temperatures below $13\text{ }^\circ\text{C}$, it often changes into an allotropic (distinctly different) form known as grey tin, which is an amorphous, greyish powder.

Lead, is a dense, bluish-grey solid metallic element at room temperature and pressure which conducts electricity and has a smaller ionization energy than carbon and silicon, it often loses two of its valence electrons to form the Pb^{2+} ions.

Special features of carbon chemistry

i) Catenation

Catenation is the ability of an element to form bonds between atoms of the same element to form long chains or ring: **-C-C-C-C-C-C-C-C-C-C-C-C-**

Carbon forms chains and rings, with single, double and triple bonds. To be able to catenate, an element such as carbon must have a valency of 2 and above.

It should also form bonds like C-C which are similar in strength to those of C to other elements, particularly C-O bonds.

Silicon forms -Si-O-Si-bonds predominantly.

ii) Multiple bonds

Carbon forms double bonds and triple bonds between carbon atoms and that bonding is formed by one Sigma bond and one π bond for double bond, one Sigma bond and two π bonds in a triple bond.

Checking-up 9.1

1. Explain the reason why diamond has a higher melting point than silicon.
2. Discuss the increase in metallic character when moving down in group 14 elements from carbon to lead.
3. Diamond and graphite are allotropes of carbon,
 - a) Draw their three dimensional structures.
 - b) With reference to their structures, compare the hardness of diamond and graphite.
4. Germanium has the same structure as diamond. Explain the type of bonds that exist in the two elements.
5. The first element in a group in the periodic table exhibits anomalous properties compared with other members. Use carbon to illustrate this statement.

9.2. Chemical properties of Group 14 elements

Activity 9.2 (a)

1. Get a piece of charcoal and burn it. Observe and write the chemical equation that represents the change that takes place when the charcoal burns.
2.
 - a) Put about 1 gram of carbon charcoal in a boiling tube.
 - b) Add 1 ml of concentrated nitric acid.
 - c) Heat strongly on a Bunsen burner flame using a test tube holder.
 - d) Observe and note the changes during heating.
 - e) Deduce the chemical changes that have occurred.
3. Write the molecular structure of carbon dioxide, carbonate ion and carbon monoxide.
4. Describe how CO_2 gas dissolves in water and state the nature of the solution formed when it is in aqueous solution.
5. Describe 2 chemical properties of amphoteric substances.

All the elements of Group 14 form four single bonds such as in tetrahalides of formula CCl_4 , SiCl_4 , GeCl_4 , SnCl_4 with the exception of PbBr_4 and PbI_4 that do not exist because bromine and iodine are not sufficiently strong oxidizing agents to convert Pb to Pb^{4+} . Germanium, tin and lead can ionize to form Ge^{2+} , Sn^{2+} and Pb^{2+} and also are capable of forming Ge^{4+} , Sn^{4+} , Pb^{4+} respectively.

Oxides of GeO₂ is more stable than that GeO. The oxide of tin in +4 oxidation state is slightly more stable than that in +2 state. Silicon oxides predominantly exist as SiO₂. SiO is too unstable to exist at room temperature and pressure but may exist at about 2000 °C. Carbon oxides are stable in +4 state. Thus CO which is unstable reacts exothermically to form the stable compound of CO₂. In lead compounds, the +2 state is more stable than +4 state. PbO₂ is unstable and is a very strong oxidizing agent.

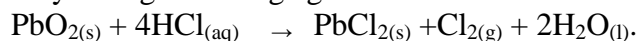

The stability of compounds with the oxidation state of +2 in group 14 elements generally increases on moving down the group from carbon to lead.

The stability of compounds with the oxidation state of +4 in group 14 elements increases on moving upward the group from lead to carbon. The bonding in tetravalent compounds is predominantly covalent.

Inert pair effect

Inert pair effect refers to the inability of the outermost s-electrons to participate in chemical bonding in Ge, Sn and Pb elements of group 14 and hence only 2 electrons of the outermost p orbital are involved.

The outermost s sub-energy level electrons are much more tightly attracted to the nucleus than the outermost p orbital. As we move down the group, the difference in energy level between s and p orbitals becomes wider.

So if we use weak oxidizing agents, only 2 electrons in p orbital are removed. If we use a strong oxidizing agent, 2 electrons in s orbital and 2 electrons in p orbital are all removed from the shell.

Reaction of group 14 elements with oxygen:

Carbon, silicon and tin directly react with oxygen to form CO₂, SiO₂ and SnO₂ respectively.

Reaction of group 14 elements with hydrogen:

Carbon graphite reacts with hydrogen gas at 30 °C to 95 °C to produce a mixture of methane (CH₄), ethane (C₂H₆) and propane (C₃H₈). The primary product is methane and the other products are produced due to free radical reaction of the methane.

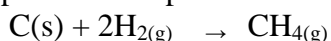

Apart from carbon, other elements of group 14 do not react with hydrogen directly.

Reaction of group 14 elements with chlorine:

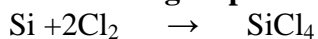

Activity 9.2 (b)

1. Put about 0.5 g of Al₂O₃ solid into **2 test tubes** then add 2ml of water.
2. Pour 3 ml of 1 mol/litre HCl solution in the **third** test tube and add 2 drops of universal indicator.
3. Pour 3 ml of 1 mol/litre NaOH solution in the **fourth** test tube and add 2 drops of universal indicator.

4. Put the first portion of Al_2O_3 solid in the test tube containing HCl solution and shake gently.
5. Put the first portion of Al_2O_3 solid in the test tube containing NaOH solution and shake gently.
6. Note the observable changes in both tests.
7. Put about 0.1 g of MgO in a test tube.
8. Add 2ml of water to the MgO solid in the test tube and shake the mixture.
9. Put 2 drops of phenolphthalein indicator in MgO solution.
10. Add 5ml of 1 mol/litre HNO_3 to the solution containing MgO solution.
11. Note the observable changes.
12. Interpret the acid –base character of the solutions of CaO and Al_2O_3 .

Reaction of group 14 elements with acids and bases:

Carbon does not react with dilute acids but reacts with hot, concentrated acids:



Silicon reacts with concentrated HNO_3 :



Silicon reacts with concentrated sodium hydroxide (base)

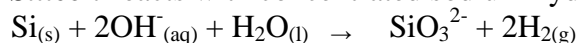

Tin reacts with concentrated nitric acid to form tin dioxide:



Cold dilute nitric acid reacts with tin to form a mixture of tin II nitrate and ammonium nitrate solution.

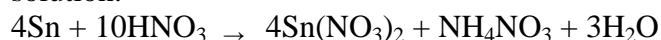

Tin is sufficiently metallic to form various mixtures of $\text{Sn}(\text{SO}_4)_2$ and hydrated SnO_2 when it reacts with **hot, concentrated** sulphuric acid.

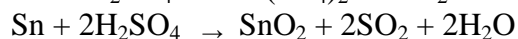
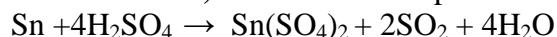

in reacts with strongly non-oxidising acids in solution.

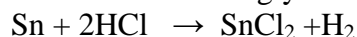

Tin reacts with **concentrated or molten sodium hydroxide base** to form a stannate ion SnO_2^{2-} and hydrogen gas:

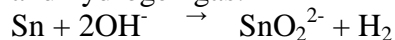

Lead reacts with hot **concentrated sulphuric acid** according to the following equation:



The reaction of lead with **concentrated nitric acid**, the equation is as follows:

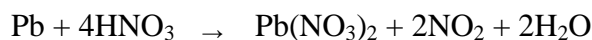

The reaction of lead with **dilute nitric acid**, the equation is as follows:



The reaction of lead with **boiling, concentrated hydrochloric acid**, the equation is as follows:

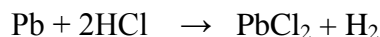

Lead which is amphoteric; reacts with **hot, concentrated sodium hydroxide** to form trihydroxoplumbate (II) and the equation is as follows:

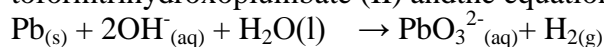

Checking-up 9.2

- 1) Explain why CO_2 does not react with acids but other dioxides of group 14 react with acids.
- 2) State the expected observation when CCl_4 and SiCl_4 are treated separately with water. Write the relevant balanced equations if the reaction is possible.
- 3) Compare the relevant stability of PbO and PbO_2 upon heating. Write the relevant balanced equations.
- 4) Suggest the way that can be used to show that Pb is amphoteric.

9.3 Distinguish between the chemical reactions of the oxides and chlorides of Group 14 elements.

Activity 9.3

1. Measure 0.5g of lead oxide or decompose the same quantity of lead nitrate crystals by heating.
2. Divide it into 5 portions and put each portion in a test tube.
3. In the first test tube, add 2mL of dilute hydrochloric acid solution in which universal indicator has been dissolved.
4. In the second test tube, add 2ml sodium hydroxide solution in which phenolphthalein indicator has been dissolved.
5. Note the observations and deduce the acid–base nature of lead oxide.

Interpretation of results of the above activity 1

The reactions that take place are:

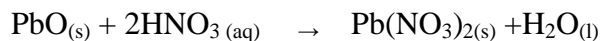
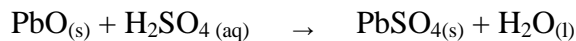
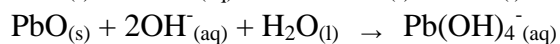
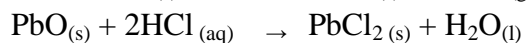
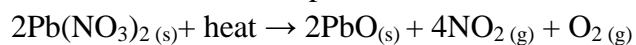

Conclusion

Lead oxide behaves as a base when it reacts with acids and behaves as an acid when it reacts with bases, thus it is an amphoteric oxide.

Reaction of CO_2 with water:

Carbon dioxide reacts with water to form carbonic acid.

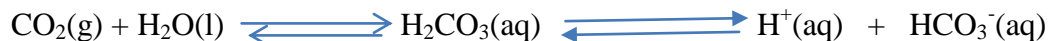

The reaction is reversible, but H_2CO_3 dissociates to produce H^{+} and HCO_3^{-} ; the dissociation of carbonic acid is also reversible since carbonic acid is a weak acid.

Carbon dioxide is an acidic oxide, so H_2CO_3 does not react with acids.

Reaction of CO_2 with sodium hydroxide:

Carbon dioxide reacts with sodium hydroxide, NaOH , to obtain sodium carbonate salt.

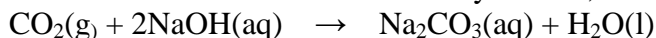

Reactions of CCl_4 with water, acids and bases:

Carbon tetrachloride (Chloromethane) does not react with water, acids, and alkaline solutions.

Reaction of SiO_2 with water: Silicon dioxide does not react with water.

Reaction of SiO_2 with acids: Silicon dioxide reacts with HF acid **only**:

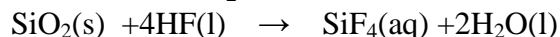

This reaction is the one used to write on the glass, for example on the windscreen of vehicle.

Reaction of SiO_2 with bases: Silicon dioxide reacts with hot concentrated NaOH solution.

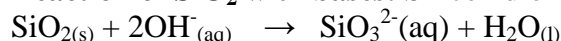

Reaction of SiCl_4 with water:

Silicon dioxide undergoes hydrolysis in water, this is due to the fact that Silicon atom possesses vacant d-orbitals that can partially accommodate an oxygen atom during the reaction unlike in the case of CCl_4 .

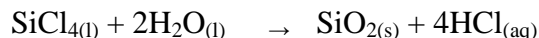

Reaction of SiCl_4 with acids, bases and water: $\text{SiCl}_4(\text{l})$ does not react with acids, bases and water.

Reaction of SnO_2 with water: SnO_2 does not react with water.

Reaction of SnO and SnO_2 with acids:

SnO_2 does not dissolve in dilute acids but it reacts with hot concentrated sulphuric acid, H_2SO_4



SnO_2 also reacts with hot concentrated HCl acid.



SnO also reacts with concentrated HCl acid.

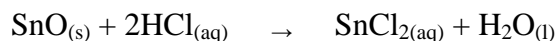

Reaction of SnO_2 and SnO with bases

SnO_2 reacts with concentrated NaOH to produce a stannate IV ion:

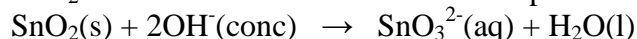

SnO reacts with dilute NaOH to produce a hydrogen stannate II ion:

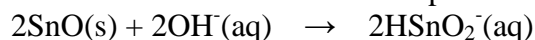

Reaction of SnO with concentrated alkali such as NaOH , disproportionation occurs in which one ion of tin in SnO gains electrons to be reduced and another ion of tin loses electrons to be oxidised.



SnO is more basic than SnO_2 due to its lower oxidation state and ionic character.

Reaction of SnCl_4 with water

SnCl_4 hydrolyses in water to produce hydrogen chloride fumes.

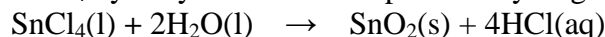

The tetrachlorides of group 14 elements are colourless liquids apart from PbCl_4 which is a yellow liquid.

SnCl_4 is unstable and it decomposes to SnCl_2 and Cl_2 .

SnCl_4 does not react with **acids nor with bases** because it is a salt which can only undergo displacement reactions with acids and bases.

Reaction of PbO_2 and PbO with water:



Figure 9.4: Lead (IV) dioxide (PbO_2) solid



Figure 9.5: Lead (II) oxide (PbO) solid

PbO_2 and PbO are amphoteric, insoluble in water but react with acids and bases. PbO is more stable than PbO_2 .

Reaction of PbO_2 and PbO with acids:

Because most lead salts are insoluble, the nature of the acid used is important, we use an acid that does not possess anions that form an insoluble salt with lead ions. So dilute HNO_3 is used:

PbO_2 and PbO react with HNO_3 , HCl and H_2SO_4 acids according to the following equations:

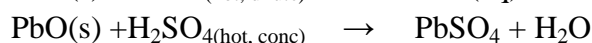
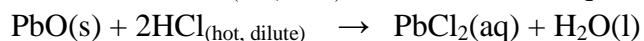
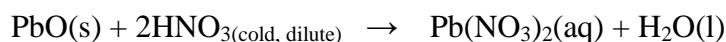

PbO_2 reacts with concentrated HCl at **room temperature** to produce PbCl_2 and it is a strong oxidizing agent.



The PbCl_2 is sparingly soluble in the cold aqueous solution but is soluble in hot water.

At 0°C , the reaction produces PbCl_4 ,

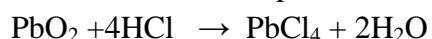

PbO_2 reacts with **hot, concentrated H_2SO_4** to produce PbSO_4 .

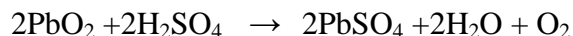

Reaction of PbO_2 and PbO with alkaline solutions:

Plumbates are formed on reaction with OH^- ,

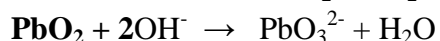
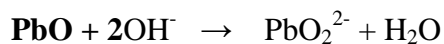

Reaction of PbCl_4 and PbCl_2 with water and HCl :

$\text{PbCl}_4 + 2\text{H}_2\text{O} \rightarrow \text{PbO}_2 + 4\text{HCl}$, the reaction is rapid.

PbCl_2 is sparingly soluble in water. So it **does not hydrolyse** in water.

PbCl_2 dissolves in concentrated HCl due to the formation of a soluble complex PbCl_4^{2-}

$\text{PbCl}_2 + 2\text{Cl}^- \rightarrow [\text{PbCl}_4]^{2-}$, PbCl_4 does not react with acids and bases since it is a salt.

Checking-up 9.3

1. For each of the following statements, state whether it is **true** or **false**.

If you consider the statement to be false, justify your answer and if it is true, give a brief explanation or write a chemical equation.

a) All group 1 elements react with water to give hydrogen gas and an alkaline solution.

b) All the oxides of group 14 with the formula of MO are amphoteric.

c) Some carbon allotropes can conduct electricity.

2. Write the equations to show the amphoteric nature of lead II oxide.

3. Discuss the reactions of tin II oxide and lead II oxide with sulphuric acid.

4. Explain why tetrachlorides of Si, Sn and Pb hydrolyse in water but carbon does not.

Write the equations of reaction for the hydrolysis of SiCl_4 and SnCl_4 .

5. Explain why PbCl_2 does not hydrolyse in water but PbCl_4 does.

9.4. Explain the trends in thermal stability of the oxide, halides and hydroxides of Group 14 elements

Activity 9.4 (a)

1. Put about 0.5 g of $\text{Pb}(\text{NO}_3)_2$ in a test tube.

2. Pour 4 ml of 1 mol/litre NaOH solution into $\text{Pb}(\text{NO}_3)_2$ solution to get a white precipitate.

3. Heat the precipitate mixture on a Bunsen burner flame.

4. Record the observable changes.

5. Explain the physical and chemical changes that you have observed.

6. Write the equations of reaction that have taken place in each chemical change.

The stability of dioxides and tetrachlorides of group 14 decreases down the group from carbon to lead due to the increase in size of the group 14 atoms.

The increase in size of group 14 atoms down the group results in **weaker bonds**. Thus PbCl_4 is the least stable of the chlorides of group 14 elements.

9.4.1. Stability of oxides of group 14 elements

The stability of XO increases downward the group from carbon to lead.

X represents: C, Si, Sn and Pb

Stability of XO increases in the order: $\text{CO} < \text{SiO} < \text{SnO} < \text{PbO}$

Carbon monoxide, CO reacts exothermically with oxygen during combustion to form CO_2 .

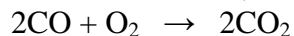

Silicon monoxide is obtained by heating SiO_2 under special conditions.



The main valency of oxides of tin, is +4, in other words SnO₂ is the most stable tin oxide; the valency of +2, SnO, is subsidiary.

On exposure to air at room temperature, SnO₂ is formed.

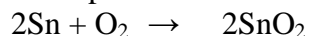

The main valency of oxides of lead, is +2, in other words, PbO is the most stable lead oxide; the valency of +4 is subsidiary. PbO is the most stable oxide of group 14 elements. PbO₂ cannot be prepared from lead monoxide because it decomposes at 300⁰C.

9.4.2. Thermal stability of halides of group 14 elements

CCl₄, SiCl₄ and GeCl₄ are very stable and they do not decompose even at high temperatures.

SnCl₄ decomposes only when it is heated to form SnCl₂ and Cl₂, so SnCl₄ is more stable.

PbCl₄ decomposes readily without heating to form PbCl₂ and Cl₂.

Thermal stability of tetrahalides of group 14 halides decreases down the group from carbon to lead because the X-halide bonds become longer and weaker down the group.

Thermal stability of tetrahalides of group 14 also decreases from fluorides to iodides.

All the tetrahalides are volatile covalent compounds except SnF₄ and PbF₄ which have some ionic character.

PbBr₄ and PbI₄ do not exist since iodine and bromine are not strong oxidizing agents enough to remove all 4 valence electrons.

9.4.3. Thermal stability of hydroxides of group 14 elements

Lead (II) hydroxide Pb(OH)₂ decomposes at temperatures ranging between 100⁰C and 145⁰C to produce PbO and H₂O .

Tin (II) hydroxide Sn(OH)₂ decomposes easily between 60⁰C and 120⁰C to produce SnO and H₂O.

Carbon and silicon are non-metals, so they don't form hydroxides.

9.4.4. Chemical tests of Sn²⁺, Pb²⁺, HCO³⁻ :

Table 9.2: Chemical tests of ions, Pb²⁺, Sn²⁺, HCO₃⁻ (aq) and CO₃²⁻ (aq) :

Reagent substance	+ test	Observation
Pb ²⁺ _(aq) + 2HCl _(aq) Colorless		White precipitate of PbCl _{2(s)} forms in cold aqueous solution, which dissolves on heating.
Pb ²⁺ _(aq) + H ₂ S _(g) Colorless		Black precipitate of PbS _(s) forms
Pb ²⁺ _(aq) + KI _(aq) Colorless		Yellow precipitate of PbI _{2(s)} forms
Pb ²⁺ _(aq) + CrO ₄ ²⁻ _(aq) Pale yellow		Deep yellow precipitate of PbCrO _{4(s)} forms
Pb ²⁺ _(aq) + 2OH ⁻ _(aq) Colorless		White precipitate of Pb(OH) _{2(s)} forms. The precipitate dissolves in excess of OH ⁻ solution.

	$\text{Pb(OH)}_2(\text{s}) + 2\text{OH}^-(\text{aq}) \rightarrow \text{Pb(OH)}_4^{2-}(\text{aq})$
$\text{Sn}^{2+}(\text{aq}) + \text{H}_2\text{S}(\text{g})$ Colorless	Brown precipitate of SnS forms.
$\text{Sn}^{4+}(\text{aq}) + \text{H}_2\text{S}(\text{g})$ Colorless	Yellow precipitate of SnS ₂ forms.
$\text{MgSO}_4(\text{aq}) + \text{HCO}_3^-(\text{aq})$ Colorless	No change.
$\text{MgSO}_4(\text{aq}) + \text{CO}_3^{2-}(\text{aq})$ Colorless	White precipitate of MgCO ₃ (s) forms

- To differentiate between HCO_3^- and CO_3^{2-} , $\text{MgSO}_4(\text{aq})$ solution is used to react with each solution of the compounds: with HCO_3^- , there is no change; with CO_3^{2-} , a white precipitate forms.
- **Both** $\text{HCO}_3^-(\text{aq})$ and $\text{CO}_3^{2-}(\text{aq})$ react with **dilute HCl** to liberate CO_2 gas which turns lime water milky as a means of detecting the gas.
- Mercury chloride, HgCl_2 solution is reduced to white precipitate of dimercury dichloride, Hg_2Cl_2 which is further reduced to a grey-black deposit of Hg by Sn II but not with Sn IV.
- Excess NaOH solution causes the white precipitate of SnO and SnO₂ oxides to re-dissolve.
- Sodium stannate II reduces the colorless bismuth nitrate, $\text{Bi(NO}_3)_3$ solution to elemental bismuth (black deposit).
- Sodium stannate IV has no reducing properties on $\text{Bi(NO}_3)_3$.

Table 9.3: Identification of ions

Activity 9.4. (b): Identifications of anions CO_3^{2-}		
Tests	Observations	Deductions
a) Heat one spatula endful of a substance in a dry test tube, first gently and then strongly until no further change. Test the gas evolved by a moist blue litmus paper	A colourless gas is given off which turns a blue litmus paper to pink	HCO_3^- , SO_4^{2-} , $\text{C}_2\text{O}_4^{2-}$, CO_3^{2-} , SO_3^{2-} suspected CO_2 and SO_2 suspected
b) To about 6 cm ³ of water, add 2 spatula endfuls of a substance. Shake and divide the solution into 3 portions	A colourless solution formed	NO_3^- , HCO_3^- , SO_4^{2-} , CO_3^{2-} , $\text{C}_2\text{O}_4^{2-}$, SO_3^{2-} of Group I elements or NH_4^+ or HCO_3^{2-} of Group (II) salt suspected
(i) To the first portion, add dil. H_2SO_4 and test the gas evolved using limewater and blue litmus paper	A colourless gas evolved which forms a milky suspension with lime water. The gas turns moist blue litmus paper pink	CO_3^{2-} , HCO_3^- , present
(ii) To the second portion, add dilute	A colourless gas evolved	CO_3^{2-} , HCO_3^- , present

HCl solution and test the gas evolved using lime water solution and moist blue litmus paper	which forms a milky suspension with lime water. The gas turns moist blue litmus paper pink	
(iii) To the third portion, add dilute nitric acid then boil, and add dilute sulphuric acid immediately followed by 2-3 drops of potassium permanganate solution.	The purple colour of potassium permanganate persists.	Oxalate, $C_2O_4^{2-}$ absent
(iv) To the fourth portion, add magnesium sulphate solution	A white precipitate formed	CO_3^{2-} confirmed

When heat is applied to a solid, to test the presence of carbon dioxide gas, CO_2 , use calcium hydroxide solution (lime water) which turns milky in the presence of CO_2 .

CO_2 can evolve from compounds containing: CO_3^{2-} , HCO_3^{2-} , $C_2O_4^{2-}$.

Checking-up 9.4

1. Give an explanation why carbon tetrachloride molecule is non-polar despite the fact that the electronegativity difference between carbon and chlorine is so big.
2. State what is observed when lead dioxide is warmed with concentrated HCl acid solution and write the equation for the reaction.
3. Lead hydroxide $Pb(OH)_2$ can react with an acid and with a base. Write the ionic equation for the reaction of $Pb(OH)_2$ with:
 - a) An acid
 - b) A base.
4. Explain the reason why lead tetrachloride is unstable such that it decomposes easily compared to other tetrachlorides of group 14 tetrachlorides.
5. You are given a mixture of HCO_3^- and SO_4^{2-} ions, explain how you can show that the mixture contains HCO_3^- ions.
6. Give a chemical reagent test(s) you can use to confirm that a solution contains Sn^{2+} ions .
7. a) Give a chemical reagent test you can use to differentiate between HCO_3^- and CO_3^{2-} ions and deduce the observable changes.
b) Write the chemical equations of reactions to illustrate the reactions that have taken place in
8. Explain the trend of thermal stability of group 14 tetrachlorides and dichlorides on descending down the group.

9.5 Explain the variation in stability of oxidation state of +2 and +4 down the Group 14 elements.

Activity 9.5

1. Write the electronic configuration of carbon and silicon.
 2. Explain the stability of dichloride compounds in group 14 elements from carbon to lead.
 3. Discuss the influence of variation in electronegativity to the bond strength in compounds of group 12 from beryllium to barium.
- Use the bond strength between MgCl_2 and CaCl_2 to explain the answer.

The 2 oxidation states exhibited by elements of group 14 are +2 and +4 in their compounds. The oxidation state of +4 involves loss of 4 valence electrons, s^2 and p^2 , while the oxidation state of +2 involves loss of only 2 electrons in the p^2 . The stability of the +2 oxidation state increases from carbon to lead while +4 oxidation state increases from lead to carbon.

Inert pair effect refers to the inability of the outermost s-electrons to participate in chemical bonding in Ge, Sn and Pb elements of group 14 and hence only the outermost p-electrons are involved.

The electrons in s orbital are much more tightly bound to the nucleus than p-electrons. As we move down the group, the difference in energy level between s sub-shell and p sub-shell becomes wider.

So if we use weak oxidizing agents, only 2-p electrons are removed. If we use a strong oxidizing agent 2 s-electrons and 2-p electrons are all removed from the shell.

If the elements in group 14 form +2 ions, they will lose the p electrons leaving the s electrons pair unused. For example, to form Pb^{2+} ions lead will lose the two 6p electrons but the 6s electrons will remain in its sub-energy level.

The inert pair effect shown in Pb^{2+} explains why the compounds of lead are predominantly ionic. Examples:

- CO is readily oxidized to the more stable CO_2 .
 - $2\text{CO}_{(g)} + \text{O}_{2(g)} \rightarrow 2\text{CO}_{2(g)}$
 - SiO can only be obtained at high temperatures when SiO_2 is heated. SiO_2 is widely distributed in sand, glass and quartz etc...
 - Ge compounds exist in the two oxidation states, the +4 is more stable. For example, GeO_2 is more stable than GeO .
 - The oxidation state of compounds of tin in +4 is slightly more stable than +2 oxidation state.
 - As a result, SnO fumes in air forming SnO_2 .
 - **Cassiterite which is the mineral ore of tin**, SnO_2 , is mined in some regions of Rwanda.
 - The oxidation state of +2 in lead compounds is more stable than +4. For example, PbO_2 decomposes to give PbO on warming.
- $$2\text{PbO}_{2(s)} \rightarrow 2\text{PbO}_{(s)} + \text{O}_{2(g)}$$

The compounds of group 14 with +4 oxidation state are more covalent than those with +2 oxidation state. The covalent character increases as a bigger anion is bonded to the group 14 element. For example, PbBr_2 is more covalent than PbCl_2 .

Checking up 9.5

1. Explain the reason why carbon does not form a CCl_2 compound.
2. Explain the term "inert pair effect".
3. Indicate which compound between PbCl_2 and PbF_2 is more covalent than another and justify.
4. Explain the reason why PbBr_4 and PbI_4 do not exist whereas PbCl_4 exists.

9.6 Uses of Group 14 elements

Activity 9.6

1. State the 2 uses of carbon in daily use.
2. Diamond is considered to be very hard, predict its application.
3. Carbon forms hydrocarbons such as methane when combined with hydrogen. State where methane is obtained in Rwanda and indicate its uses.
4. Silicon is a semi-conductor. Predict its uses in electric gadgets.
5. Tin resists corrosion of water in the presence of oxygen. Discuss where it can be used to prevent corrosion by water.

Group 14 elements are used in numerous applications. The wide applications are due to the fact that some of the elements in the group are non-metals, metals and metalloids.

Carbon uses:

- As a component of fuel for combustion as charcoal or coal.
- As the main component of crude oil and its derivatives used in our everyday life such: fuel, plastics, etc...
- As good chemical reducing agent used in extraction of metals (metallurgy).
- As a lubricant in moving parts of machines, to make electrodes, in lead pencils when mixed with clay.
- Carbon isotope, C-14 isotope is used in archaeological dating.
- Diamond is used to make glass cutters, drilling devices and as abrasive for smoothing hard materials as precious gemstone in jewelry and ornamental objects; it is also a precious stone appreciated in jewelry.

Silicon uses:

- Silicon is used as a semi-conductor in transistors in electrical gadgets such as radios, computers, amplifiers etc..
- Silicon in form of silicates is used in ceramics and in glass production.
- Silicon is also used in medicine to make silicone implants.

- Many rocks that we use for building our houses and other buildings are Silicates.
- Ferrosilicon alloy is used as a deoxidizer in steel manufacture.
- Silicon dioxide can be used to produce toothpastes and in semiconductors; silicon dioxide is the main component of sand, a raw material in the manufacture of glass.
- Tin is used in tin plating and in making alloys such as bronze and solder.

Germanium uses:

- Germanium being a metalloid, is used in transistors in electrical gadgets such radios, computers, amplifiers etc..

Tin uses:

- Tin is used in plating iron sheets to resist corrosion.
- Tin is used to make canned tins to avoid the corrosion of the materials which are in contact with an acid medium.



Figure 9.6 Tinned cans

Lead uses:

- Lead is used in making linings of vessels which are used in industrial production of sulphuric acid.



Figure 9.7: Lead bricks

- Lead bricks alloyed with 4% antimony is used in radiation shielding
- Lead is used in accumulator plates of the batteries and as shielding materials against dangerous radiations such as X-rays, gamma rays etc.



Figure 9.8: Lead acid accumulator battery

Checking –up 9.6

1. Describe how diamond is used on a large scale.
2. Describe the materials that are manufactured using lead, tin and silicon as the main component.
3. Describe 3 compounds which contain:
 - i) Silicon
 - ii) Lead.

9.7 Define diagonal relationship

Activity 9.7

1. Discuss and compare the type of bonding in beryllium and aluminium elements.
2. Describe 2 chemical properties of oxides of beryllium and aluminium compounds.
3. Describe the solubility of lithium and magnesium in water.
4. Discuss the similarities in physical properties and chemical properties of BeCl_2 and AlCl_3 .

The diagonal relationship of group 11, 12, 13 and elements:

Diagonal relationships are similarities between pairs of elements in different groups which are adjacent to other in the second and the third period of the periodic table.

These pairs (Lithium (Li) and Mg, Be and Al, boron (B) and silicon (Si)) exhibit similar properties; for example, boron and silicon are both semi-conductors, they form halides that are hydrolyzed in water and have acidic oxides.

Li	Be	B	C
Na	Mg	Al	Si

NB: This relationship does not hold for certain groups; the only significant relationships are the ones mentioned above.

Such a relationship occurs because as we move across and descend in the periodic table, there are opposite effects.

On moving across a period of the periodic table from left to right, the **size of the atoms decreases**, and on moving downward a group, the **size of the atoms increases**.

If you look into those two movements in the first 3 positions of Period 2 of the periodic table, the results: Li and Mg, Be and Al, B and Si, all couples in diagonal relationship, or diagonally adjacent resemble each other in their behavior. This resemblance, called diagonal relationship is attributed to the similarity of their size; for example the atomic radii of lithium and magnesium are similar (1.55×10^{-10} m and 1.6×10^{-10} m respectively).

Due to this relationship, those elements will show similar chemical properties and their compounds will have similar properties.

Similarly, on moving across the period, the elements become progressively **more covalent**, less basic and more **electronegative**, whereas on moving down the group the elements become more **ionic**, more basic and less electronegative.

9.7.1. Define the diagonal relationship.

Diagonal relationships are similarities between pairs of elements in different groups which are adjacent to others and in periods of the periodic table.

These are called diagonal relationships. They are not observed after B and Si. **Charge density** is the driving factor for the similarities observed in diagonal relationship.

9.7.2. Diagonal Relationship of Li with Mg:

At room temperature and pressure:

1. Li and Mg react with air to form only **normal oxides**, whereas Na forms a **peroxide** but metals below Na in the group, form **superoxide**.

2. The bicarbonates of Li and Mg do not exist in solid state, they exist in solution only.

3. Nitrates thermally decompose, to give oxides, nitrogen dioxide and oxygen:

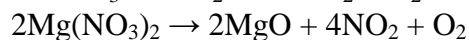
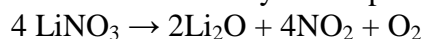

4. Hydroxides of both Li and Mg decompose on heating to give oxides. Hydroxides of both Li and Mg are weak alkalis:



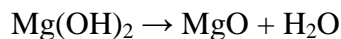

NB: Hydroxides of other alkali metals are stable on heating while their nitrates produce O₂ and nitrite: $2\text{KNO}_3 \rightarrow 2\text{KNO}_2 + \text{O}_2$

Resemblance	Li	Mg
Electronegativity	1.0	1.2
Atomic radii (nm)	1.23	1.36
Ionic radii (nm)	0.60 (Li ⁺)	0.65 (Mg ²⁺)

9.7.3. Diagonal Relationship of Be with Al

- Due to many similarities in their properties and reactions, aluminium and beryllium will be presented together even though they are in different groups of the periodic table.
Atomic radii: Be= 111 pm, Al= 143 pm
Ionic radii: Be²⁺ = 31pm, Al³⁺ = 50 pm
Boiling point: Be = 2477°C, Al =2467°C
- Oxides: BeO and Al₂O₃ are both amphoteric, the rest of Group 2 oxides are only basic.
- Reaction with dilute acids: Be and Al are fairly resistant unless amalgamated or when they are very finely divided, other Group 2 metals readily react.
- Like aluminum, beryllium is not readily attacked by acids because of the presence of an oxide film on the surface of the metal.
- Reaction with conc. nitric (V) acid: Be and Al are rendered passive, the rest of Group 2 metals readily form salts.
- Beryllium and aluminium have an appreciable covalent character of compounds (e.g. the chlorides are predominantly covalent).

9.7.4. Diagonal relationship between Boron and Silicon

Due to its small size and similar charge/mass ratio, boron differs from other group 13 members, but it closely resembles silicon, the second element of group 14 to exhibit diagonal relationship. Some important similarities between boron and silicon are as given below:

- Both boron and silicon are typical non-metals that exist as non-metallic giant covalent 3D lattices, having high melting points and boiling points, they have almost the same densities (B=2.35gml⁻¹ S=2.34 g/ml), low atomic volumes and bad conductor of electricity. However both elements are used as semiconductors.
- Both B and Si do not form cations but only form covalent compounds.
- Both B and Si form numerous volatile hydrides which spontaneously catch fire on exposure to air and are easily hydrolyzed.
- Both B and Si form weak acids like H₃BO₃ and H₂SiO₃ when they react with water.
- B and Si are non-metals and their oxides are readily soluble in alkalis.

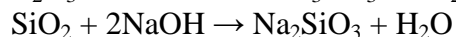
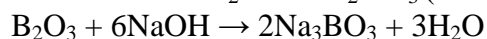
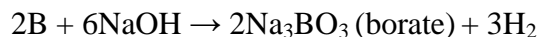

Checking-up 9.7

1. Write the chemical equation for the reaction between sodium hydroxide and:
 - a) Boron oxide
 - b) Silicon dioxide.
2. Be and Al belong to two different groups but their chlorides present the same properties; explain the origin of that resemblance.
3. Describe the volatility of hydrides of boron and silicon.
4. Explain the acidity of solutions of beryllium chloride and aluminium chloride.

9.8. End unit assessment

I: Fill in the following statements with a missing word:

1. The arrangement of atoms in diamond structure is called.....
- 2.....is the only element of group 14 whose chloride does not hydrolyse in water.
- 3.....is a semi-metallic element of group 14 whose oxide reacts with HF acid only.
- 4.....is the only element of group 14 that does not exist in various allotropic forms.
- 5.....is the only element of group 14 whose compounds in the oxidation state of +2 is more stable than that of +4.

II. Answer the following questions:

6. Write the equations for the reaction of decomposition of:
 - a) Lead (II) hydroxide
 - b) Tin tetrachloride
7. Explain the amphoteric character of tin by using appropriate equations of reaction.
8. Discuss the stability of +2 oxidation state as you move down in group 14 elements.
9. Explain the reason why the melting and boiling points of group 14 elements decrease down the group.
10. Explain by using appropriate equations, how you can confirm the presence of Sn^{2+} ions in a solution.
11. Discuss the origin of similarities of chemical properties of boron and silicon, use appropriate equations to emphasize the explanation.
12. Given the following three chlorides, CCl_4 , SnCl_2 , SnCl_4 . Classify them in two groups of ionic and covalent compounds and justify your answer.
13. Complete the following chemical equation if possible:
 - a) $\text{Sn(s)} + \text{Cl}_2(\text{g})$ (enough) \rightarrow
 - b) $\text{Sn(s)} + \text{HCl(aq)}$ (enough) \rightarrow

UNIT 10: TRENDS IN CHEMICAL PROPERTIES OF GROUP 15 ELEMENTS AND THEIR COMPOUNDS

Key unit competency: Compare and contrast the properties of Group 15 elements and their compounds, in relation to their position in the Periodic Table.

Learning objectives

By the end of this unit, I will be able to:

- Describe the physical properties of Group 15 elements.
- Describe the variation in the metallic and non-metallic character of Group 15 elements.
- Explain recall the physical properties of the allotropes of phosphorus.
- Describe the chemical reactions of nitrogen compounds.
- Describe the impact of nitrogen oxides to the environment.
- Describe the industrial preparation of ammonia and nitric acid.
- Explain the reactions of nitric acid with metals and non-metals.
- Describe the chemical properties of phosphorus compounds.
- State the uses of the group 15 elements and its compounds

Introductory activity

1. Study the figure below carefully and answer the questions that follow.

The image shows a standard periodic table of elements. The title "Periodic Table of the Elements" is centered at the top. The elements in Group 15 (Nitrogen, Phosphorus, Arsenic, Antimony, Bismuth) are circled in red. A blue arrow points from the left towards the table. Below the main table is the Lanthanide Series.

1A	2A											3A	4A	5A	6A	7A	8A	
1 H																		2 He
2 Li	Be											3 B	4 C	5 N	6 O	7 F	8 Ne	
3 Na	Mg	3B	4B	5B	6B	7B	8	9	10	11	12	13 Al	14 Si	15 P	16 S	17 Cl	18 Ar	
4 K	Ca	Sc	Ti	V	Cr	Mn	Fe	Co	Ni	Cu	Zn	31 Ga	32 Ge	33 As	34 Se	35 Br	36 Kr	
5 Rb	Sr	Y	Zr	Nb	Mo	Tc	Ru	Rh	Pd	Ag	Cd	49 In	50 Sn	51 Sb	52 Te	53 I	54 Xe	
6 Cs	Ba	*La	Hf	Ta	W	Re	Os	Ir	Pt	Au	Hg	81 Tl	82 Pb	83 Bi	84 Po	85 At	86 Rn	
7 Fr	Ra	+Ac	Rf	Ha	Sg	Nh	Hs	Mt	110	111	112	113						

* Lanthanide Series: 57 Ce, 58 Pr, 59 Nd, 60 Pm, 61 Sm, 62 Eu, 63 Gd, 64 Tb, 65 Dy, 66 Ho, 67 Er, 68 Tm, 69 Yb, 70 Lu

- Looking at the elements encircled in red, can you identify their uses or the uses of their compounds in daily life?
- What is this group referred to as?

- c) Name the diatomic element in this group.
- d) Which is the most reactive non-metal in this group?
2. Observe the illustrations below and answer the following questions



A



B



C

- a) What do you see on the above figure?
- b) Based on your knowledge concerning the use of group 15 elements, identify the domains of interest illustrated and if possible identify the element of group 15 involved.

10.1. Physical properties of group 15 elements and the relative inertness of nitrogen

Activity 10.1

In pairs:

1. Assign the physical state for each of the elements in group 15
2. Explain what is meant by the term “metallic character”.
3. Classify each element in this group as metal, non-metal or metalloid.
4. Study the following figure carefully and answer the questions that follow

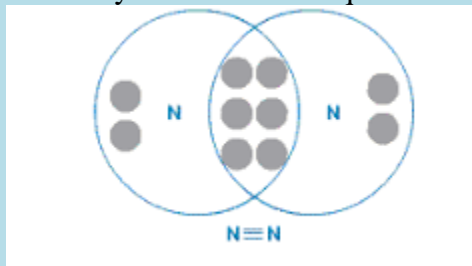

- a) Identify the molecule represented in the figure.
- b) What type of bond is there in the molecule? Classify the bond as single, double or triple

bond.

c) Suggest if the bond is strong or weak.

10.1.1. Physical properties of group 15 elements

a) Physical state

This group consists of nitrogen (${}^7\text{N}$), phosphorus (${}^{15}\text{P}$), arsenic (${}^{33}\text{As}$), antimony (${}^{51}\text{Sb}$), and bismuth (${}^{83}\text{Bi}$). This group consists of atoms having 5 electrons in their outer energy level. Two of the electrons are in the s sub-shell, with 3 unpaired electrons in the p sub-shell: ns^2np^3 ($p_x^1p_y^1p_z^1$). Group 15 Elements often form covalent compounds, usually with the oxidation numbers +3 or +5.

All the elements of this group are polyatomic. Dinitrogen is a diatomic gas while all others are solids.

- Nitrogen is a colorless gas and is the major component of air (78%).
- Phosphorus has allotropic forms and is a very reactive non-metallic element,
- Arsenic, antimony (their oxides are amphoteric) and bismuth (its oxide is basic) are somewhat solid in nature.

Table 10.1: Physical properties of group 15 elements

Element	Nitrogen (N)	Phosphorus (P)	Arsenic (As)	Antimony (Sb)	Bismuth (Bi)
Atomic Number	7	15	33	51	83
Electron Configuration	$1s^2 2s^2 2p^3$	$[\text{Ne}]3s^2 3p^3$	$[\text{Ar}] 3d^{10} 4s^2 4p^3$	$[\text{Kr}] 4d^{10} 5s^2 5p^3$	$[\text{Xe}] 4f^{14} 5d^{10} 6s^2 6p^3$
Atomic radii (nm)	0.074	0.110	0.121	0.141	0.152
Electronegativity	3.07	2.06	2.20	1.82	1.67
Melting point (${}^\circ\text{C}$)	-210	44(white) 597(red)	817	630	271
Boiling point (${}^\circ\text{C}$)	-196	280 (white) 431 (red)	613 (sublimes)	1380	1560
First Ionization Energy (kJ/mol)	1402	1012	947	834	703
Density	0.96	1.83(white) 2.34(red)	5.73	6.69	9.80
Common Physical Form(s)	Colorless Gas	White Solid/ Red Solid	Yellow Solid / Gray Solid	Yellow Solid / Silver-White Metallic Solid	Pink-White Metallic Solid

b) Metallic character

Down group 15 elements, the atomic radius increases which makes the outermost electron to be less attracted by the nucleus as you move down the group. Therefore, less energy is required to remove the outermost electron, which results in the increase in the metallic character down the group. This results also in decreasing of ionization energy down the group.

Nitrogen and phosphorous are non-metals, with the metallic properties first appearing in arsenic and increasing down the group. Arsenic and antimony are metalloids. Bismuth is a metal.

10.1.2. The relative inertness of nitrogen

The most striking aspect of nitrogen chemistry is the inertness of N_2 itself. Nearly four-fifth of the atmosphere consists of nitrogen, and the other fifth is nearly all oxygen, a very strong oxidizing agent. Nevertheless, the searing temperature of a lightning bolt or very high temperature in a vehicle motor combustion is required for significant amounts of atmospheric nitrogen oxides to form. Thus, even though N_2 is inert at moderate temperatures, it reacts at high temperatures with H_2 , Li, Group 2 members, B, Al, C, Si, Ge, O_2 , and many transition elements. In fact, nearly every element in the periodic table forms bonds to N, but at high temperature.

Nitrogen is found as a diatomic molecule (N_2) in nature. There is a triple bond between the two nitrogen atoms. This explains the very high strength of the nitrogen-nitrogen triple bond ($N\equiv N$) that requires high energy, 942 kJmol^{-1} , to be broken. For comparison, the single bond (N-N) and the double bond ($O=O$) require 247 kJmol^{-1} and 498 kJmol^{-1} respectively.

Checking Up 10.1

- Briefly describe how each of the following factors vary in group 15 elements:
 - Atomic radius
 - Electron affinity
 - Melting point
 - First ionization energy
- Arsenic, antimony and bismuth are metals which are widely distributed as sulphides. They are extracted by reduction of the roasted sulphide ore.
 - Explain what is meant by the term "ore"
 - Which substance is used to reduce roasted sulphide ore?
- Explain the following observations:
 - In group 15 of the periodic table, metallic character increases as you move down the group.
 - The atomic radii of two elements A and B from group 15 are 0.121 nm and 0.141 nm respectively. Identify the element with more metallic character. Justify your answer.

10.2. Reactions of group 15 elements

Activity 10.2

1. Explain what is meant by the term:
 - a) Hybridisation
 - b) Electronic configuration
2. Like carbon, nitrogen has four valence orbitals (one 2s and three 2p), so it can participate in at most four electron-pair bonds by using sp^3 hybrid orbitals. Unlike carbon, however, nitrogen does not form long chains. Explain why.
3. Briefly explain what is meant by:
 - a) Acidic oxide
 - b) Basic oxide
 - c) Amphoteric oxide
4. Respond by **True** or **False**
 - a) Nitrogen is the only member of the group that readily forms multiple covalent bonds.
 - b) Nitrogen is the most electronegative member of group 15 elements and the only one that can be involved in the formation of hydrogen bond
 - c) Nitrogen is the only group member that forms an ion E^{3-}
 - d) Only nitrogen form oxides of the form: E_2O_3 and E_2O_5

All group 15 elements exhibit a common valency of three. They can complete their octet structure in chemical combination by gaining three electrons.

However, with the exception of nitrogen, group 15 elements have vacant d-orbitals which they use to expand their octet to form compounds with a valency of five. For instance phosphorous has a covalency of 5 due to availability of easily accessible empty d orbitals which can be used for sp^3d hybridization that allows it have 5 unpaired electrons. Consider phosphorous, atomic number 15.

Ground state electronic configuration of P: $1s^2 2s^2 2p^6 3s^2 3p^3 3d^0$ (three unpaired electrons)



After sp^3d hybridization, the 5 electrons previously in $3s^2 3p^3$ are redistributed in the five hybrid orbitals sp^3d :

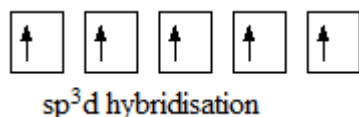

Hence phosphorus can now accommodate 5 more electrons or create 5 covalent bonds.

The same applies for any element in the group, such as Bi, that participates in a five covalency bonding.

Reaction with oxygen

All group 15 elements form two types of oxides: E_2O_3 and E_2O_5 . The oxide in the higher oxidation state of the element is more acidic than that of lower oxidation state. Their acidic character decreases down the group. Group 15 oxides of the form E_2O_3 of nitrogen and phosphorus are purely acidic, those of arsenic and antimony amphoteric and that of bismuth predominantly basic.

Nitrogen gas does not react with air under normal conditions. Nitrogen (II) oxide is produced when nitrogen combine with oxygen. This is further oxidized into nitrogen (IV) oxide:

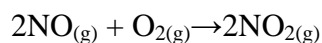
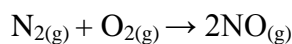

By combustion of phosphorus in oxygen, two phosphorus oxides can be produced:

(a) In limited oxygen, phosphorus (III) oxide is formed:

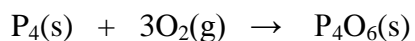

(b) In excess oxygen, phosphorus (V) oxide is formed

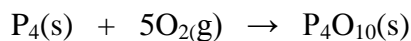

Reaction with water

Elements in this group do not tend to react with water. Nitrogen gas does not react with water. Phosphorous does not react with cold water. However, phosphorous vapour reacts with steam at high temperatures.

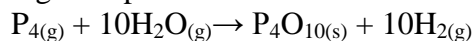

Reaction with chlorine

White phosphorous readily ignites in chlorine to form the trichloride and in excess of chlorine, the pentachloride is produced. Red phosphorous behaves similarly when heated:

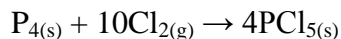
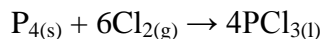

Reaction with hydrogen

All Group 15 elements form hydrides of the type EH_3 , where E = N, P, As, Sb or Bi. The hydrides show regular gradation in their properties. The stability of hydrides decreases from NH_3 to BiH_3 which can be observed from their bond dissociation energy. Consequently, the reducing character of the hydrides increases down the group. NH_3 is only a mild reducing agent while BiH_3 is the strongest reducing agent amongst all the hydrides. Basicity also decreases in the order:



Under normal conditions the nitrogen gas is very inert, but, Nitrogen reacts with Hydrogen at a high temperature (about 500°C) and extremely high pressure (200-1000 atm) over a catalyst (consisting of finely divided iron (Fe) and aluminum oxides a promoter). These are conditions used in the manufacture of ammonia, NH_3 :

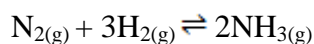

Reaction with metals

All group 15 elements react with metals to form their binary compounds exhibiting -3 oxidation state, such as, Ca_3N_2 (calcium nitride), Ca_3P_2 (calcium phosphide), Na_3As_2 (sodium arsenide), Zn_3Sb_2 (zinc antimonide) and Mg_3Bi_2 (magnesium bismuthide).

Nitrogen combines with many metals to form metal nitride:

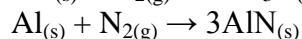
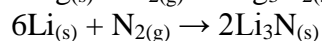
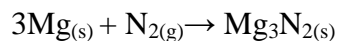

Checking Up 10.2

1. Group 15 elements form compounds by gaining three electrons, for example in the formation of ionic nitrides such as Li_3N , Ca_3N_2 , Mg_3N_2 and AlN , in which nitrogen forms N^{3-} . Other large atoms do not form M^{3-} . Explain why.
2. State how the stability of $+5$ oxidation state varies in group 15.
3. The atomic number of an element A is 33.
 - a) Write the electronic configuration of A using s,p,d, notation.
 - b) Write the molecular formula of all possible oxide of A.
 - c) i) State whether each oxide of A you have given in (b) is acidic, basic, neutral, or amphoteric.
ii) Write the equation of reaction to illustrate your answer.

10.3. Ammonia and nitric acid

Activity 10.3 (a)

Experiment: Laboratory preparation of ammonia

Materials and chemicals

Round bottom flask or hard glass test tube, U-tube, 3 corks, 10 grams of calcium hydroxide, gas

jars, bent delivery tube and straight delivery tube, 5 grams of ammonium chloride on a watch glass and calcium oxide lumps.

Procedure

1. Set up the apparatus as shown in the diagram, with the chemicals indicated. Do not start heating yet.
2. When everything is in position, heat the hard flask and collect several gas jars of ammonia. Cover each jar with a glass slip and keep the jars for other experiments.

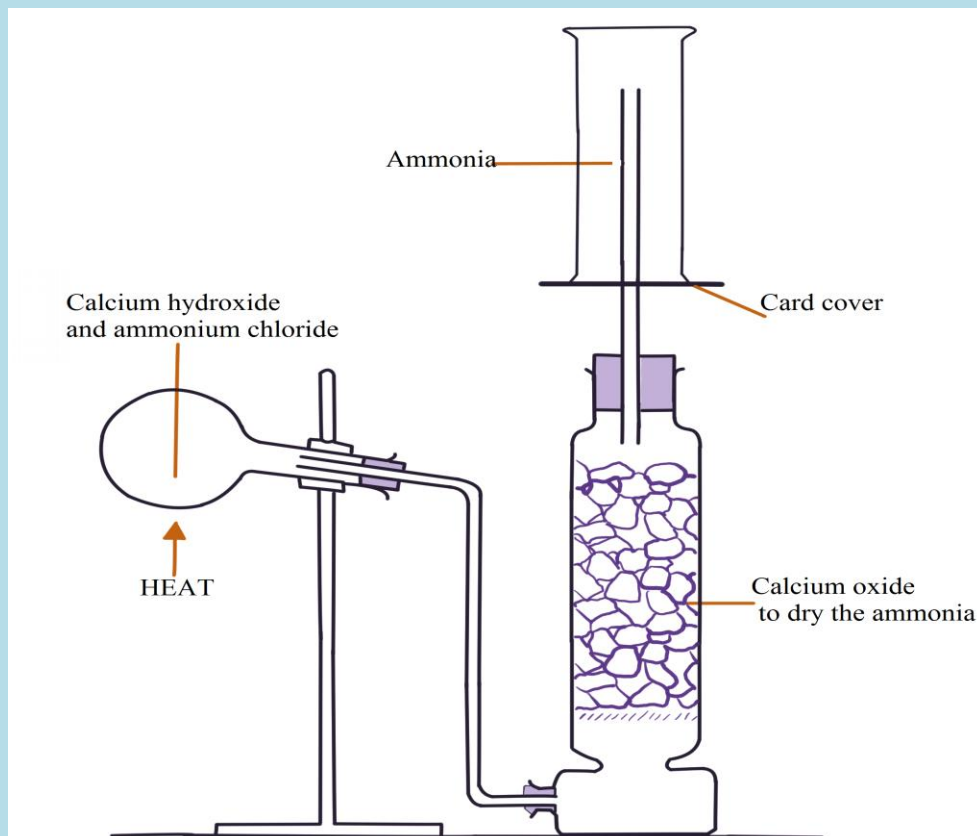

Activity evaluation questions

1. Record your observations
2. Write a balanced equation of the reaction that takes place.

10.3.1. Laboratory preparation of ammonia and nitric acid

a) Laboratory preparation of ammonia

Ammonia is a covalent compound, consisting of nitrogen bonded to three hydrogen atoms. It exists as a colourless gas at room temperature and is naturally produced during the decaying of nitrogenous organic compounds such as proteins. Ammonia has a characteristic pungent odour. It

is denser than air and thus collected by upward delivery method. In the laboratory it is prepared by heating a mixture of any ammonium salt and an alkali.

Examples

Ammonium salts	Alkalis
Ammonium nitrate (NH ₄ NO ₃)	Calcium hydroxide, Ca(OH) ₂ (Slaked lime)
Ammonium chloride (NH ₄ Cl)	Sodium hydroxide, NaOH
Ammonium sulphate (NH ₄) ₂ SO ₄	Potassium hydroxide, KOH
Ammonium carbonate (NH ₄) ₂ CO ₃	

Ionic equation for the reaction:

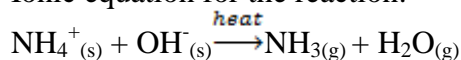

Case study: Preparation of ammonia from calcium hydroxide and ammonium chloride

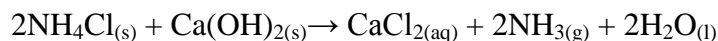

b) Laboratory preparation of Nitric acid

Nitric acid can be prepared in the laboratory by the action of hot concentrated sulphuric acid on any nitrate salt. Preferably potassium nitrate or sodium nitrate can be used, though potassium nitrate is a better choice since sodium nitrate is hygroscopic:

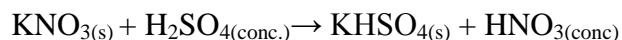

10.3.2. Industrial production of ammonia and nitric acid

a) Production of ammonia (Haber process)

The Haber process combines nitrogen from the air with hydrogen derived mainly from natural gas (methane) into ammonia. The reaction is reversible and the production of ammonia is exothermic.



This reaction, which is reversible one, requires special conditions for an optimum yield of ammonia

- Pressure : 200 –1000 atmospheres
- Temperature: 450- 500°C
- Catalyst: finely divided iron (Fe) catalyst, aluminium oxide which is added to the catalyst to improve its performance (a promoter). It makes it more porous and this provides a high surface area to the reaction and potassium oxide

The ammonia formed can either be liquefied or dissolved in water to separate it from the mixture.

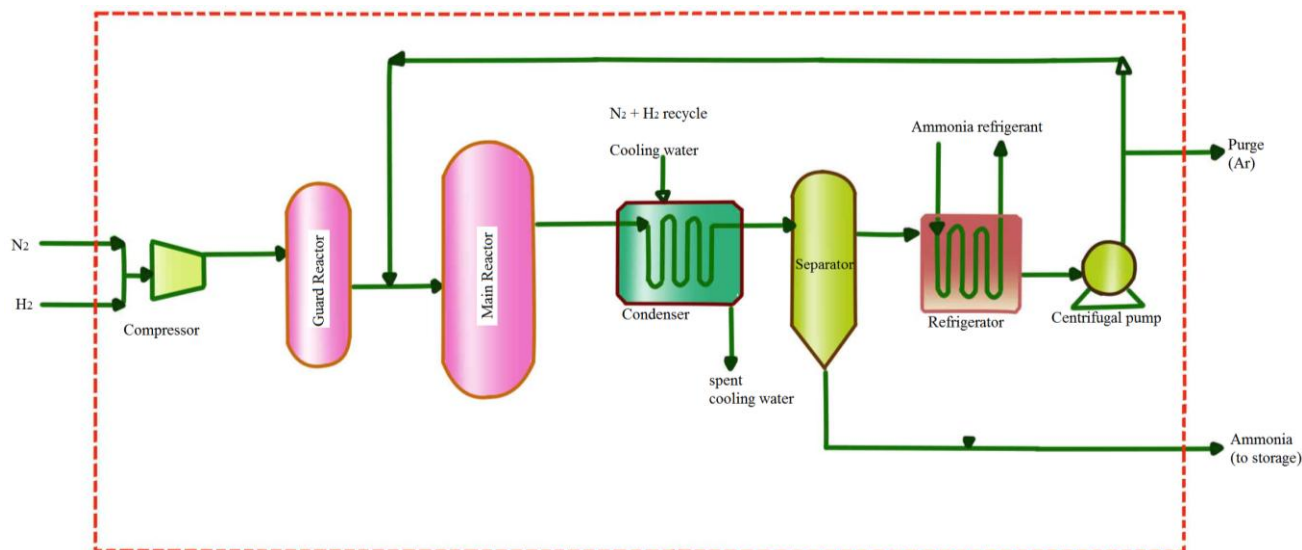
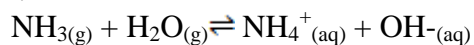

Figure 10.1: A diagram for the production of ammonia using Haber process

i) Chemical reactions of ammonia

Ammonia is colorless gas, very soluble in water. It dissolves in water forming $\text{NH}_4\text{OH}_{(\text{aq})}$ solution.



Reaction of ammonia with acids (HCl):

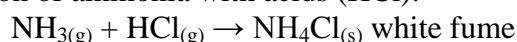

Reaction with oxygen

Ammonia burns in an atmosphere enriched with oxygen with a greenish-yellow flame in absence of a catalyst to form nitrogen and steam.

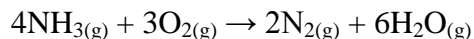

In the presence of a catalyst (for example, platinum wire or copper wire), ammonia is oxidized to nitrogen monoxide.

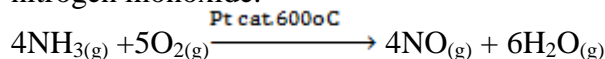

Ammonia can be a reducing agent

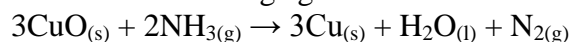

ii) Uses of ammonia

Agricultural industries are the major users of ammonia. Ammonia and urea are used as fertilizer, a very valuable source of nitrogen that is essential for plant growth.

Ammonia and urea are used as a source of protein in livestock feeds for ruminating animals such as cattle, sheep and goats.

Ammonia can also be used as a pre-harvest cotton defoliant, an anti-fungal agent on certain fruits and as preservative for the storage of high-moisture corn.

The pulp and paper industry uses ammonia for pulping wood and as casein dispersant in the coating of paper.

The food and beverage industry uses ammonia as a source of nitrogen needed for yeast and microorganisms involved in the fermentation process.

iii) Environmental impact for industrial production of ammonia

Making ammonia using the Haber process requires a lot of energy, which usually involves burning fossil fuels. This releases carbon dioxide which causes global warming. Oxides of nitrogen are also emitted during the process; once in atmosphere they mix with water vapour to form acidic solutions or acid rain. Acid rain is a pollutant that can render acidic lakes and soils.

b) Production of Nitric acid (Oswald's process)

In the industrial manufacture of nitric acid a catalytic oxidation of ammonia to nitrogen (II) oxide, NO, is carried out then a further oxidation of nitrogen II oxide produces nitrogen (IV) oxide, NO₂. The nitrogen dioxide is passed through water sprays in a steel absorption tower to produce nitric acid. The excess nitrogen monoxide is recycled back for more oxidation. Platinum is used as a catalyst. There are three steps:

Step 1: Production of NO by oxidation of NH₃:

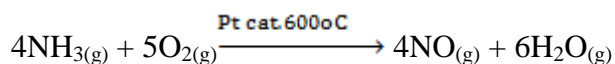

The oxidation of ammonia is carried out in a catalytic chamber at a temperature of about 600°C; the catalyzer is a platinum gauze.

Step 2: Oxidation of NO into NO₂:

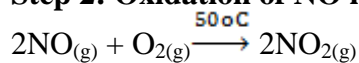

Nitric oxide (nitrogen monoxide) gas obtained by the oxidation of ammonia is very hot. In order to reduce its temperature, it is passed through a heat exchanger where the temperature of nitric oxide is reduced to 150°C. Nitric oxide after cooling is transferred to another oxidizing tower where at about 50°C it is oxidizing to NO₂.

Step 3: Formation of HNO₃ by mixing NO₂ and water

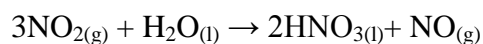

Nitrogen dioxide from the second oxidation chamber is introduced into a special absorption tower. NO_2 gas passed through the tower and water is showered over it. By the absorption, nitric acid is obtained.

Nitric acid so obtained is very dilute. It is recycled in an absorption tower so that more and more NO_2 get absorbed. HNO_3 after recycle becomes about 68% concentrated.

In order to increase the concentration of HNO_3 , vapour of HNO_3 is passed over concentrated H_2SO_4 . Being a dehydrating agent H_2SO_4 , absorbs water from HNO_3 and concentrated HNO_3 is obtained.

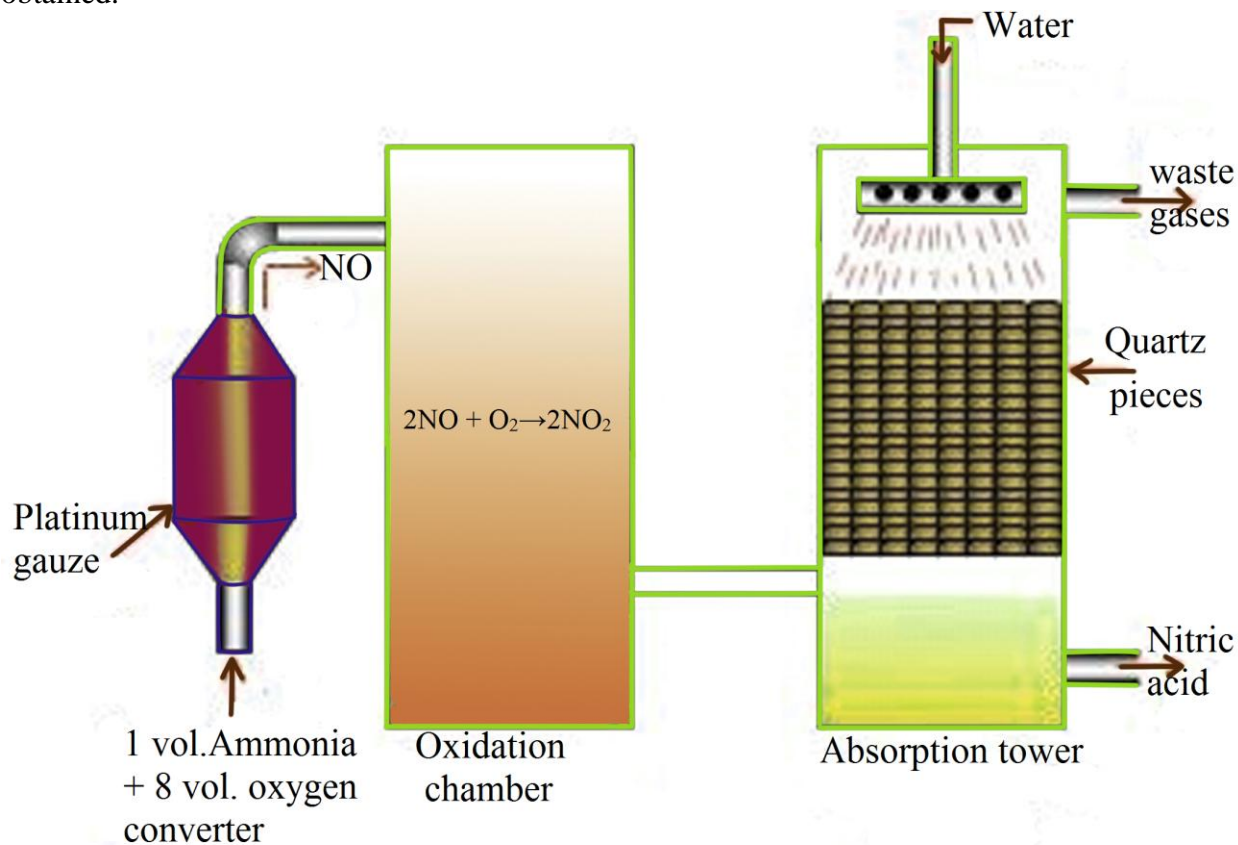

Figure 10.2: A diagram for the production of nitric acid using Oswald's process

i) Chemical properties of nitric acid

Activity 10.3 (b)

Investigating reactions of HNO_3 with metals

Caution

Work in a well ventilated room

Avoid big yield of the gas when HNO_3 reacts with non-metals and metals. The gas is toxic.

Concentrated acids are corrosive; much care must be taken in using

Materials and chemicals

Concentrated nitric acid, copper turnings, magnesium ribbon, aluminium powder, carbon (or charcoal), sulphur powder, red and blue litmus paper, spatula, source of heat.

Procedure

1. Collect apyrex beaker or a clean test tube.
2. Pour 5 cm³ of concentrated HNO₃ in the beaker or 2 cm³ of the same acid in the test tube.
3. Add a small piece, 2g to 4g of magnesium to the container.
4. Using wet blue and red litmus paper, check the nature of the gas produced.
5. Record your observations.
6. Repeat the experiment but at step (3) replace magnesium with copper turnings.
7. Record your observations.

Reactions of nitric acid with metals

Reaction with Magnesium

Unlike other acids, nitric acid rarely gives off hydrogen gas with metals except for very dilute nitric acid (about 1%) which reacts with magnesium liberating hydrogen gas.

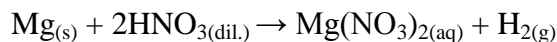

Reaction with Zinc

Concentrated nitric acid reacts with zinc to give mainly ammonium nitrate, although some NO₂ may be formed.



But zinc reacts with dilute nitric acid to form nitrogen (I) oxide.

Reaction with copper

Concentrated nitric acid reacts with copper oxidizing it to copper (II) nitrate, Cu(NO₃)₂, and is itself reduced to nitrogen (IV) oxide:

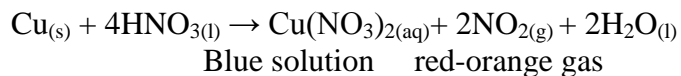

But dilute nitric acid reacts with copper to produce nitrogen (II) oxide, NO.

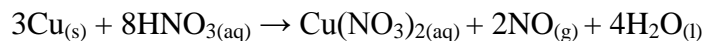

This reaction explains why nitric acid is called an “oxidizing acid”; in opposition of acids that cannot dissolve copper called non-oxidizing acids, e.g. HCl(aq), H₃PO₄(aq).

This reaction can be used to distinguish between a gold sample and a copper sample; gold and copper have almost the same color. If a sample is gold, it does not dissolve in nitric acid; if it is copper, it dissolves in nitric acid to form a blue solution.

Reaction with Lead

Lead reacts with concentrated nitric acid in similar way to copper.

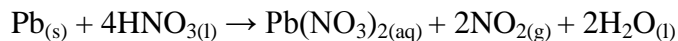

Activity 10.3 (c): Investigate reaction of concentrated HNO₃ with non-metals. e.g carbon, and sulphur,

Materials and chemicals

Concentrated nitric acid, carbon (or charcoal), sulphur powder, red and blue litmus paper, spatula, source of heat.

Procedure

1. Have a pyrex beaker.
2. Put one spatula of carbon powder into a beaker; add about 5cm³ of concentrated nitric acid.
3. Record your observations.
4. If no reaction is taking place, gently heat the mixture.
5. Test the gas produced with a wet blue and red litmus paper.
6. Record your observations.

Procedure 2

1. Collect a pyrex beaker.
2. Measure one spatula of sulphur powder into the beaker. Add about 5cm³ of concentrated nitric acid.
3. Record your observations.
4. If no reaction is taking place, gently heat the mixture.
5. Test the gas given off with a wet blue and red litmus paper.
6. Record your observations.

You can also replace the concentrated HNO₃ with dilute nitric acid (1M) and record your observations.

Activity evaluation questions

1. Write balanced equations of the reactions taking place when concentrated nitric acid is used.
2. Write balanced equations of the reactions when dilute nitric acid (1M) is used.
3. Write the formula of the gas given off in all the experiments done.
4. Is the gas released acidic or basic? Explain your answer.

Reactions of nitric acid with non-metals

Nitric acid or fuming one gives the most vigorous reaction giving off brown fumes of nitrogen dioxide. Warning! These reactions can be violent, and nitrogen dioxide is very poisonous

Reaction with Carbon

Hot concentrated nitric acid oxidises carbon to CO₂:

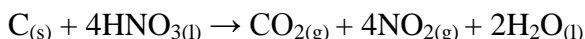

Reaction with Sulphur

Concentrated or fuming nitric acid reacts with sulphur to give reddish-brown fumes of nitrogen (IV) oxide (NO₂). Two or three drops of bromine can be added to catalyse the reaction.



Adding barium solution to the solution formed forms white precipitate as a test for the presence of sulphate ions (SO₄²⁻).

Reaction with Phosphorous

Hot concentrated nitric acid oxidises phosphorous to H₃PO_{4(aq)}



Reaction with Iodine

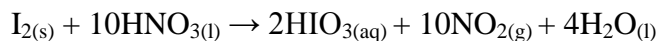

Oxidizing power of nitric acid

When hydrogen sulphide, H₂S, is passed through dilute nitric acid solution, a pale yellow sulphur precipitate is formed. H₂S is oxidized to sulphur and HNO₃ is reduced to nitrogen (II) oxide gas.

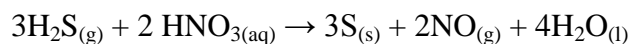

ii) Uses of nitric acid

The main industrial use of nitric acid is the production of nitrates as fertilizers. Nitric acid is neutralized with ammonia to give ammonium nitrate.

Others uses are: manufacture of dyes, artificial fiber and drugs, making gun powder and explosives such as trinitrotoluene (TNT)

iii) Environmental impact of industrial production of nitric acid

The manufacture of nitric acid may constitute an environmental problem if appreciable quantities of nitrogen oxides, NO_x, are rejected into atmosphere; because they form acid rains, and can contribute the greenhouse effect and global warming.

The main gaseous emissions from the Ostwald process include NO and NO₂. Both gases contribute to photochemical smog, and therefore, careful attention must be paid to minimizing the emission of those gases into the atmosphere. Note that Nitrogen (I) oxide is a significant greenhouse gas.

Checking Up 10.3

1.
 - a) State whether NH₃ is a Lewis acid or Lewis base
 - b) Explain your answer in (a) above
2. Explain briefly how ammonia is prepared in the laboratory.
3. How nitric acid is prepared in the laboratory? Use equation to illustrate your answer.
4. Ammonia is a gas used to manufacture various compounds.
 - a) State 3 physical properties of ammonia gas.
 - b) The manufacture of Ammonia in the Haber process is a key industry that is linked to other useful chemicals.
 - i) Write a balanced equation for the reaction that occurs in the Haber process.
 - ii) State the conditions of temperature, pressure and catalyst used in this process.
 - iv) With the help of balanced equations, outline the steps involved in the manufacture of nitric acid from ammonia.
5. Write equations to show how ammonia reacts with the following:
 - a) Oxygen in the absence of a catalyst
 - b) Oxygen in the presence of a catalyst
 - c) Copper (II) oxide
 - d) Hydrochloric acid
6. Write equations to show how nitric acid reacts with the following substances:
 - a) Copper
 - b) Sulphur
 - c) Potassium hydroxide

10.4. Phosphorus and chemical properties of its compounds

Activity 10.4 (a)

Study the figure below and answer the questions asked

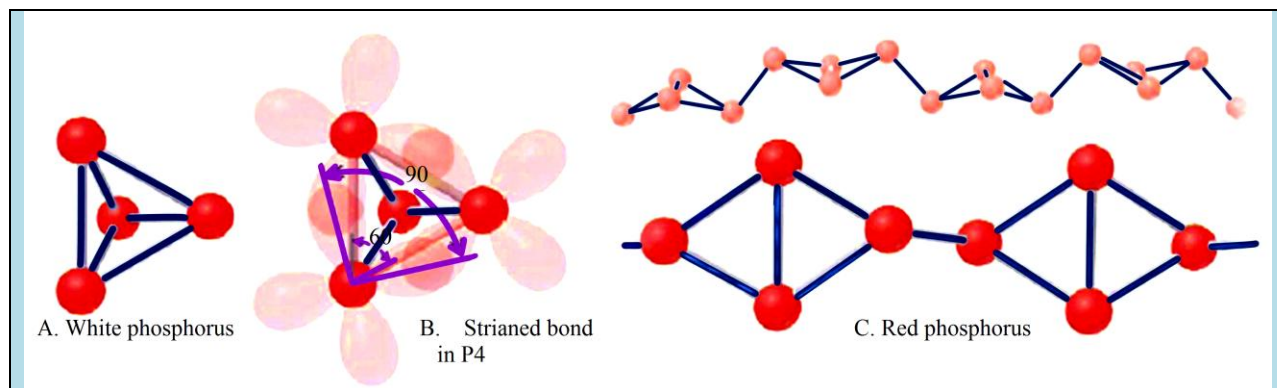

A. White phosphorus

B. Strained bond in P₄

C. Red phosphorus

1. Explain what is meant by “allotropes” of an element
2. How red phosphorus and white phosphorus differ?
3. Write balanced equations to show how the following oxides are obtained from phosphorous:
 - a) P₂O₃
 - b) P₄O₁₀
4. How does phosphorous reacts with chlorine?

10.4.1. Allotropes of phosphorus

By definition, allotropy is a property exhibited by some elements to exist in multiple forms with different crystal structures. Allotropes are any two or more physical forms in which an element can exist. Phosphorus exists in two main allotropic forms:

- White phosphorus
- Red phosphorus

a) White phosphorus (P₄)

White phosphorus (P₄) exists as molecules made up of four atoms in a tetrahedral structure. The tetrahedral arrangement results in [ring strain](#) and instability.



Figure 10.3: white phosphorus molecule

When prepared, ordinary phosphorus is white, but it turns light yellow when exposed to sunlight. It is a crystalline, translucent, waxy solid, which glows faintly in moist air and is extremely poisonous. It ignites spontaneously in air at 34°C and must be stored under water. It is insoluble in water, slightly soluble in organic solvents, and very soluble in carbon disulfide. White phosphorus melts at 44.1°C, boils at 280°C. White phosphorus is prepared commercially by heating calcium phosphate with sand (silicon dioxide) and coke in an electric furnace. When heated between 230°C and 300°C in the absence of air, white phosphorus is converted into the red form. White phosphorus is considered and has been used as a chemical weapon.

b) Red phosphorus

It is a micro-crystalline, nonpoisonous powder. It sublimates (passes from the solid state directly to the gaseous state) at 416°C . As shown in the figure below, its structure is made of a chain of P_4 units, a kind of polymer: $\dots(\text{P}_4)_n\dots$

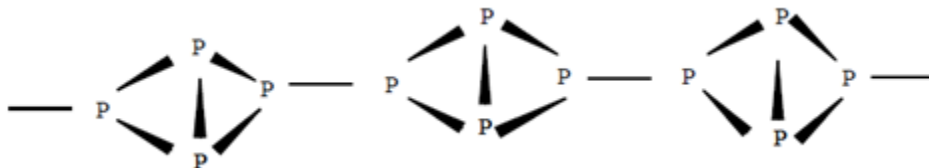

Figure 10.4: The arrangement of atoms in red phosphorus

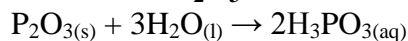

Figure 10.5: Match heads containing red phosphorus

Some of the reactions of phosphorous were discussed above. (See section 10.2).

10.4.2. Chemical properties of phosphorous compounds

Reaction of P_2O_3 with water:



Reaction of P_2O_5 with water:

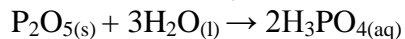

Reaction of PCl_3 with water, oxygen, chlorine:

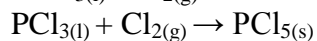
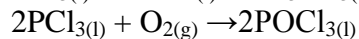
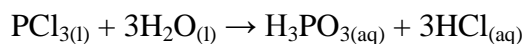

Reaction of PCl_5 with water:

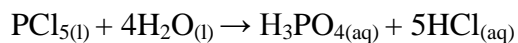

10.4.3. Phosphoric acid

a) Laboratory preparation of phosphoric acid

In the laboratory phosphoric acid can be prepared by boiling a mixture of red phosphorus with 50% nitric acid in a flask fitted with a reflux condenser on a water bath till no more oxides of nitrogen are liberated. Iodine acts as a catalyst.

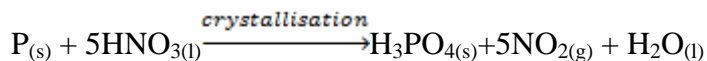

Phosphoric acid is also obtained from phosphorus oxide, P_4O_{10} : $\text{P}_4\text{O}_{10(s)} + 6\text{H}_2\text{O}_{(l)} \rightarrow 4\text{H}_3\text{PO}_{4(aq)}$

This oxide is obtained when phosphorus is burnt in excess supply of air: $\text{P}_{4(s)} + 5\text{O}_{2(g)} \rightarrow \text{P}_4\text{O}_{10(s)}$
Phosphoric acid can also be obtained by heating calcium phosphate or bone ash with dilute sulphuric acid at a temperature less than 180°C , and the insoluble calcium sulphate is filtered off:

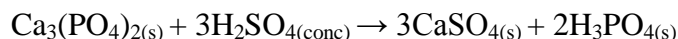

b) Reaction of phosphoric acid (H_3PO_4) with metals and bases

i) Reaction with some metals

Phosphoric acid reacts with magnesium, copper, and lead to form metal (II) phosphate:

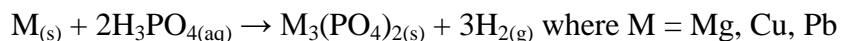

Reaction with aluminium

Phosphoric acid reacts violently with aluminium powder producing much heat and hydrogen gas. The hydrogen gas given off burns in limited air and releases a big explosion.

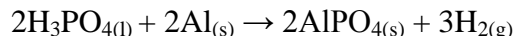

Much care should be taken when carrying out experiment involving phosphoric acid. Do not burn the colourless gas given off.

ii) Reaction with bases

Phosphoric acid reacts with bases to form salt and water. This is a neutralization reaction with evolution of heat.

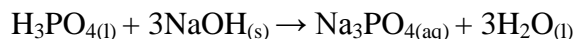

10.4.4. Identification of PO_4^{3-} and NO_3^- ions

Activity 10.4 (b)

Experiment: Investigating the presence of nitrate ion (NO_3^-)

Chemicals and apparatus needed are:

1. Freshly prepared iron (II) sulphate solution
2. Concentrated sulphuric acid
3. Test tubes
4. Droppers

Procedure:

1. To about 1cm^3 of suspected solution of nitrate, add an equal volume of prepared iron (II) sulphate and tilt the tube.
2. Add cold concentrated H_2SO_4 slowly on the sides of the test tube.

Study questions

1. Record your observations
2. What is the name given to this test?

Identification of NO_3^- ions

- a) Brown ring test: the test carried out in Activity 10.4(b) is called “Brown ring test”. When the test is carried out as indicated, a brown ring is slowly formed between the two layers (acid and aqueous layers).
- b) Addition of concentrated sulphuric acid: When a solid nitrate is mixed with about 1cm^3 concentrated sulphuric acid and warmed, brown fumes of nitrogen dioxide are formed.
- c) Boiling nitrates with powdered Devarda’s alloy (a mixture of copper, zinc and aluminium) gives a colourless gas with a choking smell. The gas is ammonia.

Identification of PO_4^{3-} ions

Formation of immediate yellow precipitate of ammonium phosphomolybdate when a solution of phosphate (V) is warmed with nitric acid and ammonium molybdate solution confirms a phosphate (V) ion in solution. Heptaoxidophosphates (V), $\text{P}_2\text{O}_7^{4-}$, and trioxophosphates (V), PO_3^- , also give yellow precipitates with the reagents but at a slow rate. The yellow precipitate is due to the hydrolysis of phosphates (V) on warming.

10.4.5. Uses of group 15 elements and compounds

a) Uses of Phosphorus

The main uses of Phosphorus are:

1. Red phosphorus is mainly used on making matches.
2. White phosphorus and zinc phosphate are mainly used as a poison for rats.
3. Phosphorus is used in making phosphor bronze, which is an alloy of copper and tin containing phosphorus.
4. Phosphorus is used for the preparation of phosphorous compounds like P_2O_5 , PCl_3 , PCl_5 and phosphoric acid. Phosphoric acid, in turn, is used in the manufacture of phosphates which are used as fertilizer: NPK (Nitrogen, Phosphate, and Potassium) fertilizer.
5. It is used in making incendiary (fire causing) bombs, tracer bullets and for producing smoke screen.

b) Uses of Nitrogen and its compounds

1. Ammonia and Nitrates are used as fertilisers to increase soil fertility.
2. Nitric acid is used in making explosives such as trinitrotoluene (TNT), and in the production of nitrates.
3. Nitrogen is a constituent of almost every major class of drugs, including antibiotics. In the form of nitrous oxide, nitrogen is used as a pharmaceutical anesthetic agent.
4. Cryopreservation (conservation at low temperature) also uses nitrogen to conserve egg, blood, sperm and other biological specimens at very low temperature.
5. Nitrogen gas is used in laboratory or hospital to create inert atmosphere
6. Ammonia is used in the manufacture of nitric acid, a starting material for the production of chemical fertilizers such as ammonium sulphate, ammonium nitrate, and many other kinds of nitrate fertilizers.
7. The compound ammonium nitrate mixed with large quantity of salt in water can be used as a freezing mixture.
8. Ammonia is used in the manufacture of aminobenzene dyes.

c) Uses of Arsenic

1. Arsenic is used in semi-conductor electronic devices
2. Arsenic is also used in various agricultural insecticides and poisons.
3. Metallic arsenic is in alloying with lead

Checking Up 10.4

1. What is another name given to yellow phosphorus?
2. Why is white phosphorus stored in water?
3. Write an equation to show how phosphoric acid reacts with calcium hydroxide
4. The chloride and oxide of phosphorus in the higher oxidation state are: PCl_5 and P_2O_5 .
 - a) Give the formulae of the chloride and oxide of phosphorus in a lower oxidation state.
 - b) Write a balanced equation for the reaction of PCl_5 with water.

- c) Write a balanced equation for the reaction of P_2O_5 with water.
- d) 25cm^3 of the resulting solution of the reaction between P_2O_5 and water reacted completely with 25cm^3 of 0.6mol dm^{-3} NaOH. Calculate the concentration of the solution.
- e) What is the name of the shape of PCl_5 ? Give one of the bond angles in that shape.

10.1.1. Environmental problems of using chemical fertilizers of nitrates and phosphates

Nitric acid is mainly used in the manufacture of nitrates fertilizers. Excess use of nitrates as fertilizers is responsible of one type of pollutions of lakes and rivers called eutrophication.

Eutrophication results from the excessive richness of nutrients in a lake or a water body which causes a dense growth of plant life. When those water plants die and are decomposed, during the decomposition process that uses oxygen, they deplete the oxygen of the water body and render that water incapable of sustaining living organisms. In that case, the body of water is said to be dead (biologically).

The fraction of the nitrogen-based fertilizers which is not converted to be used by plants accumulates in the soil or lost as run-off. High application rates of nitrogen-containing fertilizers combined with the high water solubility of nitrate leads to increased runoff into surface water as well as leaching into groundwater, thereby causing groundwater pollution.

Ammonium nitrate fertilizers can cause soil acidification when added. This may lead to decreases in nutrient availability which may be offset by liming. High levels of fertilizer may cause the breakdown of the symbiotic relationships between plant roots and mycorrhizal fungi.

Conclusion: Use of chemical fertilizers such as nitrates is good because it allows increasing of soil fertility. But we may be careful to avoid that excess of those fertilizers becomes a pollution problems for our soil, lakes and water bodies.

10.5 End unit assessment

Multiple choice questions

1. $\text{HNO}_3 + \text{P}_2\text{O}_5 \rightarrow \text{A} + \text{B}$, A is an oxyacid of phosphorous and B is an oxide of N. A and B may be one of the following:

- a) $\text{H}_3\text{PO}_4, \text{N}_2\text{O}_3$ b) $\text{HPO}_3, \text{N}_2\text{O}_3$ c) $\text{HPO}_3, \text{N}_2\text{O}_5$ d) $\text{H}_3\text{PO}_3, \text{N}_2\text{O}_5$

QUESTION: Identify A and B.

2. When heated NH_3 is passed over CuO . The gas evolved may be one from the list below. Identify which one.

- a) N_2 b) N_2O c) HNO_3 d) NO_2

3. When concentrated nitric acid is heated it decomposes to give one from the list below. Identify which one.

- a) O_2 and N_2 b) NO c) N_2O_5 d) NO_2 and O_2

4. Which of the following metal produces nitrous oxide with dilute HNO_3

- a) Fe b) Zn c) Cu d) Ag

5. Which Nitrogen trihalides is least basic and why?

- a) NF_3 b) NCl_3 c) NBr_3 d) NI_3

6. P_4O_6 reacts with water to give one of the following. Identify which one.

- a) H_3PO_3 b) $\text{H}_4\text{P}_2\text{O}_7$ c) HPO_3 d) H_3PO_4

7. Which one does not form complex in the list below; justify your answer:

- a) N b) P c) As d) Bi

8. Nitrogen dioxide is released by heating one of the following: identify which one.

- a) $\text{Pb}(\text{NO}_3)_2$ b) KNO_3 c) NaNO_2 d) NaNO

Short and long answer Open questions

1. Though nitrogen exhibits +5 oxidation state, it does not form pentahalide. Give a reason.

2. PH_3 has lower boiling point than NH_3 . Why?

3.

a) Write the equation for the reaction to prepare ammonia gas from ammonium chloride and calcium hydroxide

b) i) Which other ammonia salt can be used in place of ammonium chloride?

ii) How can you show that ammonia is an alkaline gas?

iii) State three large scale uses of ammonia.

4.

a) Describe how nitric acid reacts with copper (your answer should include equations for the reactions and clear observations).

b) Give two reactions that show how nitric acid can behave as an acid and as an oxidizing agent

c) State two uses of HNO_3 .

5.

a) When phosphorous (P) burns in air, it reacts with oxygen to produce an oxide. Write a chemical equation for the reaction of phosphorous with oxygen.

b) Phosphorous pentachloride (PCl_5) is one of the chlorides of phosphorous. Deduce the oxidation state of phosphorous atom in phosphorous pentachloride (PCl_5) molecule.

c) Give two uses of phosphorous compounds.

UNIT 11: TRENDS OF CHEMICAL PROPERTIES OF GROUP 16 ELEMENTS AND THEIR COMPOUNDS

Key unit competence:

The learner should be able to compare and contrast the chemical properties of the Group 16 elements and their compounds in relation to their position in the Periodic Table.

Learning objectives

By the end of this unit, I will be able to:

- Describe the physical properties of Group 16 elements.
- Describe the reactions between sulphur and oxygen.
- Describe the steps and conditions applied in the industrial preparations of sulphuric acid.
- Describe the chemical properties of sulphuric acid.
- Describe the properties of oxoanions.
- State uses of the Group 16 elements and compounds.

Introductory activity

Study the following figure and answer the question that follow

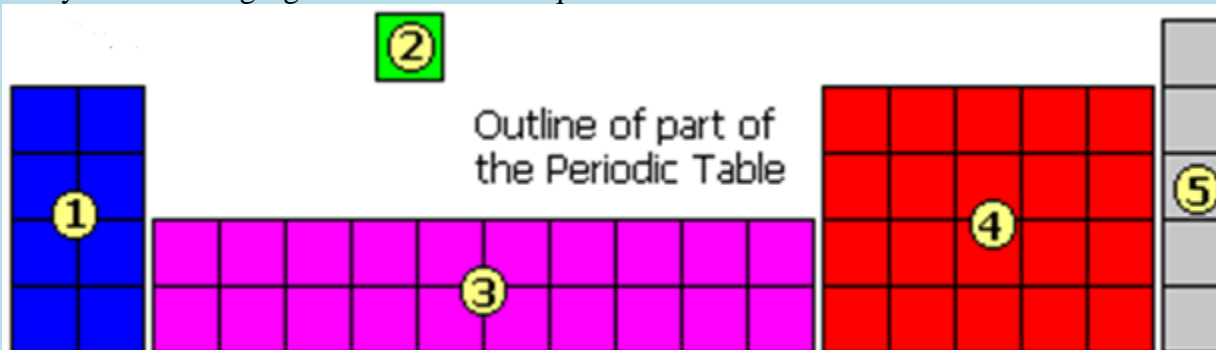

1. The diagram shows an outline of part of the Periodic Table in five sections. In which section will you find group 16 elements?
2. Write the electronic configuration of all group 16 elements
3. What do group 16 elements have in common?

11.1. Physical properties of group 16 elements

Activity 11.1

Study carefully the following figure and answer the questions that follow

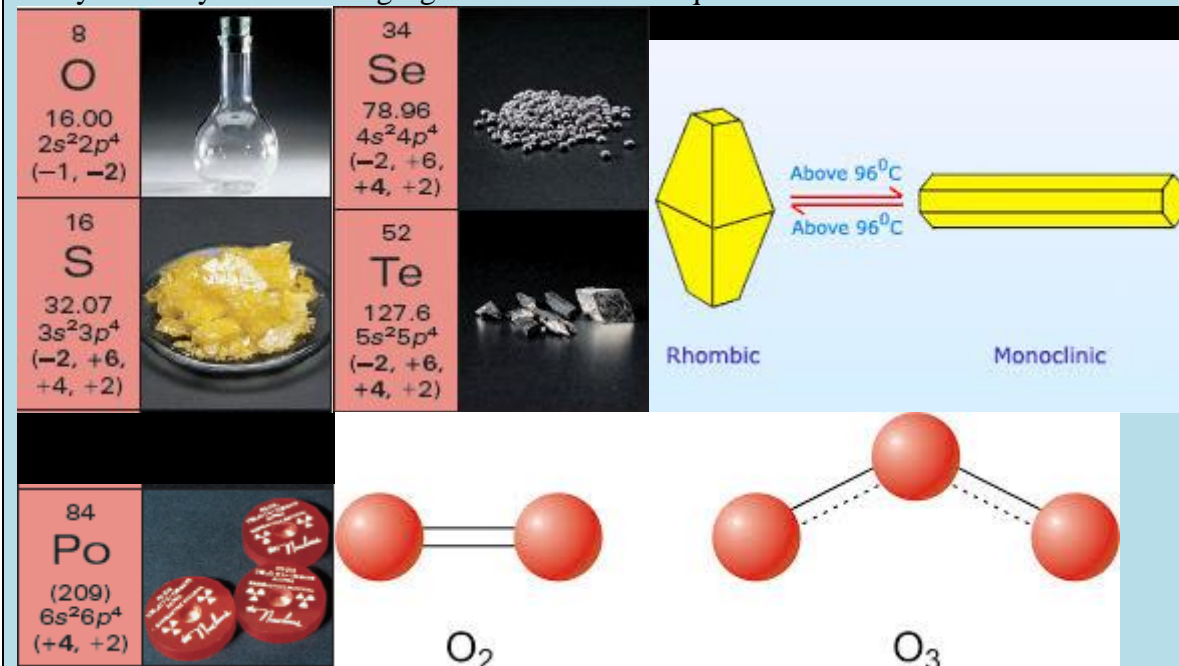

1. What do you observe on the above figure?
2. Using your own observation and knowledge, predict the physical state of each of the elements in the figure.
3. Which one of the following best defines the word “allotropes”?
 - a) Different structural forms of an element
 - b) A pair of substances that differ by H⁺
 - c) Elements that possess properties intermediate between those of metals and nonmetals
 - d) Atoms of a given atomic number that have a specific number of neutrons
 - e) The different phases (solid, liquid or gas) of a substance

11. 1.1. Physical state and metallic character of group 16 elements

This group consists of oxygen (⁸O), sulphur (¹⁶S), selenium (³⁴Se), tellurium (⁵²Te), and polonium (⁸⁴Po). It is also known as group of chalcogens. The name is derived from the Greek word for brass and points to the association of sulphur and its congeners with copper. Most copper minerals contain either oxygen or sulphur and frequently the other members of the group. Group 16 elements have the valence-shell electron configuration $ns^2 np^4$. There is a steady change down the group from non-metallic to metallic properties.

Oxygen is a colourless gas, a non-metal. Sulphur is a white and waxy non-metal solid. Selenium has acidic oxides only. It is classified as a semi metal or metalloid. Tellurium has amphoteric oxides, so it is a semi-metal or metalloid element. Polonium is a silvery metallic solid. The melting and boiling points increase with the increase in atomic number down the group. The large difference between the melting and boiling points of oxygen and sulphur may be explained using their atomicity. Oxygen exists as diatomic molecule (O_2) whereas sulphur exists as polyatomic molecule (S_8).

Table 11.1: Physical properties of group 16 elements

Element	Oxygen	Sulphur	Selenium	Tellurium	Polonium
Atomic Number	8	16	34	52	84
Electronic Configuration	$[He]2s^2 2p^4$	$[Ne]3s^2 3p^4$	$[Ar]3d^{10}4s^2 4p^4$	$[Kr]4d^{10}5s^2 5p^4$	$[Xe]4f^{14}5d^{10}6s^2 6p^4$
Atomic radii (nm)	0.074	0.104	0.117	0.137	0.140
Electronegativity	3.4	2.6	2.6	2.1	2.0
Melting point ($^{\circ}C$)	-218	119	217	450	254
Boiling point ($^{\circ}C$)	-183	445	685	990	960
First Ionization Energy (kJ/mol)	1314	1000	941	869	812
Density (g/cm^3)	1.31 (g/l)	2.07	4.81	6.24	9.20

11.1.2. Allotropes of oxygen and sulphur

a) Oxygen

Oxygen is a gas at room temperature and is colorless, odorless, and tasteless. It is the most abundant element by mass in both the Earth's crust and the human body. It is second to nitrogen as the most abundant element in the atmosphere (21%).

Oxygen has two allotropes, dioxygen (O_2) and trioxygen (O_3) (see in Activity 11.1). In general, O_2 (or dioxygen) is the form referred to when talking about the elemental or molecular form because it is the most common form of the element. The O_2 bond is very strong, and oxygen can also form strong bonds with other elements. However, compounds that contain oxygen are considered to be more thermodynamically stable than O_2 itself.

Dioxygen is a colourless and odourless gas. It liquefies at 90 K ($-183^{\circ}C$) and freezes at 55 K ($-218^{\circ}C$). Oxygen atom has three stable isotopes: ^{16}O , ^{17}O and ^{18}O . Dioxygen directly reacts with nearly all metals and non-metals except some metals (e.g., Au, Pt) and some noble gases. Its combination with other elements is often strongly exothermic which helps in sustaining the reaction. However, to initiate the reaction, some external heating is required as bond dissociation energy of oxygen-oxygen double bond is high (493.4 kJmol^{-1}).

The other allotrope, ozone, is a pale-blue poisonous gas with a strong odor. It is a very good oxidizing agent, stronger than dioxygen, and can be used as a substitute for chlorine in purifying

drinking water without giving the water an odd taste. However, because of its unstable nature it disappears and leaves the water unprotected from bacteria. A layer of Ozone at very high altitude in the atmosphere is responsible for protecting the Earth's surface from ultraviolet radiations; however, at lower altitudes it becomes a major component of smog.

a) Sulphur

Sulphur occurs in native state, in volcanic lands and some sedimentary lands. Sulphur occurs as free element underground in some countries such as USA and Japan. Sulphur also occurs in many important metallic sulphides (0.05% of earth's crust), such as lead sulfide, or galena, PbS ; zinc blende, ZnS ; copper pyrite, $(\text{CuFe})\text{S}_2$; cinnabar, HgS ; stibnite, Sb_2S_3 ; and iron pyrite FeS_2 . It is also combined with other elements in the form of sulfates such as barite, BaSO_4 ; celestite, SrSO_4 ; and gypsum, $\text{CaSO}_4 \cdot 2\text{H}_2\text{O}$, and it is present in the molecules of many organic substances such as mustard, eggs, hair, proteins, oil of garlic, in petrol and coal.

Sulfur exists in a variety of forms called allotropes, which consist of several solid varieties, of which the most familiar are rhombic sulfur and monoclinic sulfur.

Rhombic sulphur (α -sulphur) (see figure in Activity 11.1)

Rhombic sulphur consists of yellow, translucent, octahedral crystals. It is stable below 96°C and it slowly changes to monoclinic at temperatures above 96°C . The temperature of 96°C is the transition temperature. It melts at 113°C . It has a density of 2.06gcm^{-3} .

Monoclinic Sulphur (β -sulphur) (see figure in Activity 11.1)

Monoclinic Sulphur is stable above 96°C up to its melting point of 119°C . It consists of needle-shaped amber transparent crystals with density of 1.98gcm^{-3} . Below 96°C , monoclinic sulphur changes to rhombic sulphur. This type of allotropy, in which one form changes to the other depending on the temperature, is called enantiotropy.

The most common naturally occurring allotrope, S_8 , cyclo-octasulphur, has a zigzag arrangement of the atoms around the ring.

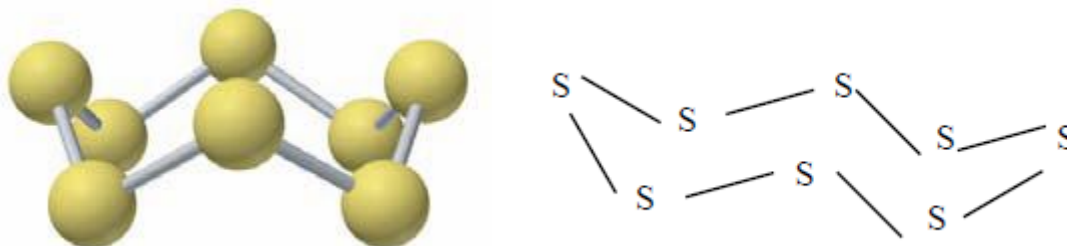

Figure 11.1: Arrangement of atoms in sulphur molecule

All forms of sulfur are insoluble in water, but the crystalline forms are soluble in carbon disulfide.

The most stable variety of the element is rhombic sulfur, a yellow, crystalline solid with a density of 2.06 g/cm^3 at 20°C . Rhombic sulfur is slightly soluble in alcohol and ether, moderately soluble in oils and extremely soluble in carbon disulfide. When kept at temperatures above 94.5°C but below 120°C the rhombic form changes into monoclinic sulfur.

When ordinary sulfur melts, it forms a straw-colored liquid that turns darker with additional heating and then finally boils. When molten sulfur is slowly cooled, its physical properties change in accordance with the temperature, pressure, and method of crust formation.

Checking Up 11.1

1. True or false
 - a) Sulphur is a non-metal element
 - b) Rhombic sulphur is stable above 96°C
2. List the important sources of sulphur
3. Elements of Group 16 generally show lower value of first ionisation energy compared to the corresponding periods of group 15. Why?

11.1. Comparison of acidity and volatility of group 16 hydrides

Activity 11.2

1. In pairs, carry out research and write a note on the following terms:
 - a) Hydrides
 - b) The strength of an acid
 - c) A weak acid
 - d) A strong acid
2. With the help of an example, explain what is meant by the term “hydrogen bond” and show how it is formed.
3. What are the effects of hydrogen bond in molecules?

All group 16 elements form hydrides of the type H_2E ($\text{E} = \text{O}, \text{S}, \text{Se}, \text{Te}, \text{Po}$). They are bent in shape. Group 16 hydrides, contrary to group 1 & 2 hydrides, are covalent. Their acidic character increases from H_2O to H_2Te . The increase in acidic character down the group can be explained in terms of increase of ionic character of the metallic hydrides, allowing easy dissociation in water to liberate H^+ ion. The acidic nature is in the order, $\text{H}_2\text{O} < \text{H}_2\text{S} < \text{H}_2\text{Se} < \text{H}_2\text{Te}$.

Owing to the decrease in energy of dissociation of H-E bond down the group, the thermal stability of hydrides also decreases from H_2O to H_2Po . Thermal stability is in the order: $\text{H}_2\text{O} > \text{H}_2\text{S} > \text{H}_2\text{Se} > \text{H}_2\text{Te} > \text{H}_2\text{Po}$.

The main hydrides of group 16 are hydrogen oxide (H_2O) known as water and hydrogen sulphide (H_2S), the rotten egg smelling and poisonous gas.

Hydrogen oxide (H_2O) is a liquid at room temperature because of strong intermolecular forces (hydrogen bond). Water is neutral (neither acid nor base).

Hydrogen sulphide (H_2S) is a colorless gas with a repulsive smell similar to that of a rotten egg. It is also fairly soluble in water. It is one of the weakest acids known, this gas is extremely poisonous. H_2O and H_2S are both polar molecules therefore two molecules of H_2O near each other, and two molecules of H_2S near each other have dipole-dipole force between them. Yet the dipole-dipole force between two molecules of H_2O is a special type of dipole-dipole force called Hydrogen bonding. And since Hydrogen bond is a stronger dipole-dipole force than that of a normal dipole-dipole bond the boiling point of water will be abnormally greater than that of hydrogen sulphide.

Checking Up 11.2

1. Give and explain the order of acidic nature of hydrides of group 16 elements.
2. H_2S is less acidic than H_2Te . Why?
3. Given two hydrides H_2S and H_2O . Which one is more thermally stable? Justify your answer.
4. H_2O and H_2S are hydrides of two elements belonging to the same group; yet H_2O is liquid at room temperature, whereas H_2S is gaseous. Explain why?

11.2. Preparation and properties of sulphuric acid

Activity 11.3

1. Do you know sulphuric acid?
2. If yes, what do you know about it?
3. How will you proceed if you are mixing sulphuric acid with water?

Experiment: Investigating the dehydrating power of Sulphuric acid on sugar

Materials and chemicals:

1. 70 grams granulated sugar, $\text{C}_{12}\text{H}_{22}\text{O}_{11}$
2. 70 ml of concentrated (18M) sulfuric acid, H_2SO_4
3. 300 ml tall-form beaker
4. 40cm stirring rod
5. Paper towels
6. Disposable gloves or
7. 100 ml graduated cylinder
8. Tray
9. 1 liter beaker
10. Sodium bicarbonate, NaHCO_3
11. Spatula

Safety:

Sulfuric acid is a very strong acid and is extremely corrosive to skin. Wear gloves and safety

goggles. During the reaction, steam is generated. It is hot. It is recommended to work in a fume cupboard.

Procedure:

Spread some paper towels on the tray.

1. Put sugar into 300 ml beaker.
2. Insert stirring rod into center of sugar.
3. Put beaker on paper towels on the tray.
4. Add 70 ml of sulfuric acid to the sugar and stir briefly.
5. Stand about 1 - 2 meters away and wait for reaction to begin and observe what will happen.

Clean Up: You might want to incorporate part of the clean up procedure into the demonstration. Remove black carbon column from the beaker and put it into a liter beaker with some sodium bicarbonate (hydrogen carbonate). With spatula, break the column of carbon into smaller pieces. Add a little water and set back on the tray. The foaming action is also exciting. Neutralize any acid spills with sodium bicarbonate and wipe clean. Leave lecture hall clean for the next class.

Rinse all glassware and carbon chunks with lots of water. Carbon can be thrown away in trash.

Study questions

1. Record your observations
2. Write equation that take place in this experiment

11.3.1.Industrial preparation of sulphuric acid and its environmental impact

a) Preparation

Sulphuric acid is manufactured industrially using the contact process which is based on the catalytic oxidation of SO_2 to SO_3 . In this process, there are five steps:

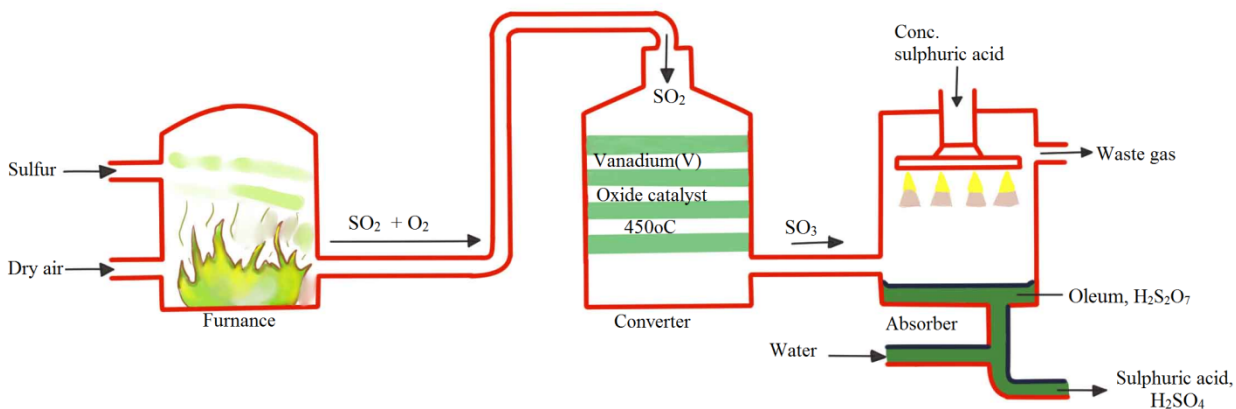
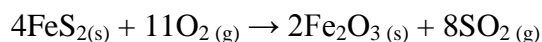
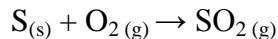

Figure 11.2: A diagram for the production of sulphuric acid using contact process

Step 1: Production of sulphur dioxide

Sulphur dioxide is obtained by either burning elementary sulphur or roasting metal sulphides in air in combustion chamber.



Step 2: Purification of gases

The SO₂ produced in Step1 contains many impurities (e.g arsenic III oxide) and these impurities would poison the catalyst (platinum, Pt) by rendering it ineffective. The mixture is passed through a purifier chamber.

Step 3: Oxidation of SO₂ to SO₃

The purified gases (mixture of SO₂ and O₂) are dried and passed through converters containing a catalyst, vanadium (V) oxide V₂O₅ or fine divided platinum and at temperature about **450°C**.

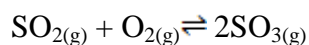

The reaction is exothermic and once the reaction has started no external heat is required. The evolved heat maintains the temperature of the catalyst.

Step 4: Absorption of SO₃

The SO₃ is an anhydride of sulfuric acid, direct absorption of it in water gives a very vigorous reaction and forms droplets of sulphuric acid. To overcome this problem, SO₃ is absorbed in the sulfuric acid in which it dissolves with ease in the absorption tower to form oleum or pyrosulphuric acid.

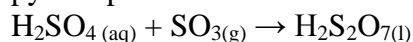

Step 5: Dilution of oleum

The oleum formed is diluted with the correct quality of water to give concentrated sulphuric acid 98%.

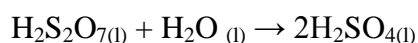

b) Environmental impact of the industrial manufacture of sulphuric acid

Industrial emissions of sulfur oxides result into the increase of the concentration of sulfuric acid (H₂SO₄) and sulfurous acid (H₂SO₃) in the atmosphere. Those acids are present as particles or droplets which dissolve in clouds, fog, rain, dew, or snow, resulting in very dilute acid solutions. This constitutes a kind of pollution called acid rain. Acid rains cause acidification of soils and lakes, and destruction of some buildings, infrastructures and statues made in marble or other carbonaceous rocks.

11.3.2. Oxidising and dehydrating properties of sulphuric acid

a) Oxidizing properties

Hot concentrated Sulphuric acid is an oxidizing agent:



In other conditions, sulphuric acid is not considered as an oxidizing acid. When dilute, sulphuric reacts with other metals to form metal sulphates, and hydrogen gas, but it doesn't attack copper.

b) Dehydrating properties

Concentrated sulphuric acid has a high affinity for water. It shows this property when it reacts with sugars, hydrated copper (II) sulphate, ethanol, oxalic acid and other organic matter. For example:

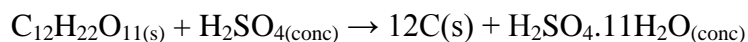
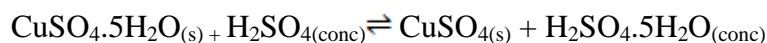

Black mass

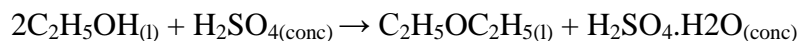
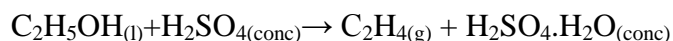

Because of this, concentrated sulphuric acid is used as a drying agent in laboratories. It is also this property that makes sulphuric acid destroy or burn any object containing cellulosic matter such as paper, clothes, skin, etc...).

Checking Up 11.3

1. a) Describe the Haber process for the manufacture of sulphuric acid.
b) Why is sulphur trioxide formed in this process not absorbed directly in water?
2. Concentrated sulphuric acid acts as a dehydrating agent. What does it mean?
3. Write equations to show how concentrated sulphuric acid reacts with:
 - a) Zinc
 - b) Magnesium
 - c) Carbon

11.3. Properties of oxoanion of sulphur

Activity 11.4 (a)

1. Use the library and/or internet to explain the following:
 - a) Oxidation
 - i) In terms of oxidation state

- ii) In terms of electron transfer
- b) Reduction
 - i) In terms of oxidation state
 - ii) In terms of electron transfer
- c) Oxidizing agent
- d) Reducing agent

Activity 11.4 (b)

2. An experiment for Heating hydrated copper(II) sulfate

Objectives:

Students remove the water of crystallisation from hydrated copper (II) sulfate by heating. Condensing in a test-tube collects the water. The white anhydrous copper (II) sulfate can then be rehydrated, the blue colour returns.

Apparatus and equipment (per group)

1. Two test-tubes
2. Delivery tube (right angled)
3. 250cm³ beaker for cold water bath
4. Bunsen burner
5. Clamp and stand

Chemicals (per group)

Hydrated copper (II) sulfate (powdered) (Harmful).

Teaching tips

Ensure that the reaction test-tube is clamped as shown on the figure. Warn about and watch for 'suck back'. Demonstrate how to lift the entire clamp stand and apparatus

Background theory

Some reactions are easily reversible and others are not. Concept of water of crystallization

Safety

Wear eye protection

Procedure

1. Set up the apparatus as shown.
2. Heat the blue copper (II) sulfate until it has turned white.
3. Act quickly to prevent suck back. Lift the clamp stand so that the delivery tube does not reach into the water in the test-tube.
4. Allow the anhydrous copper (II) sulfate to cool.
5. Hold the tube containing anhydrous copper (II) sulfate in one hand and pour the condensed water onto the powder.

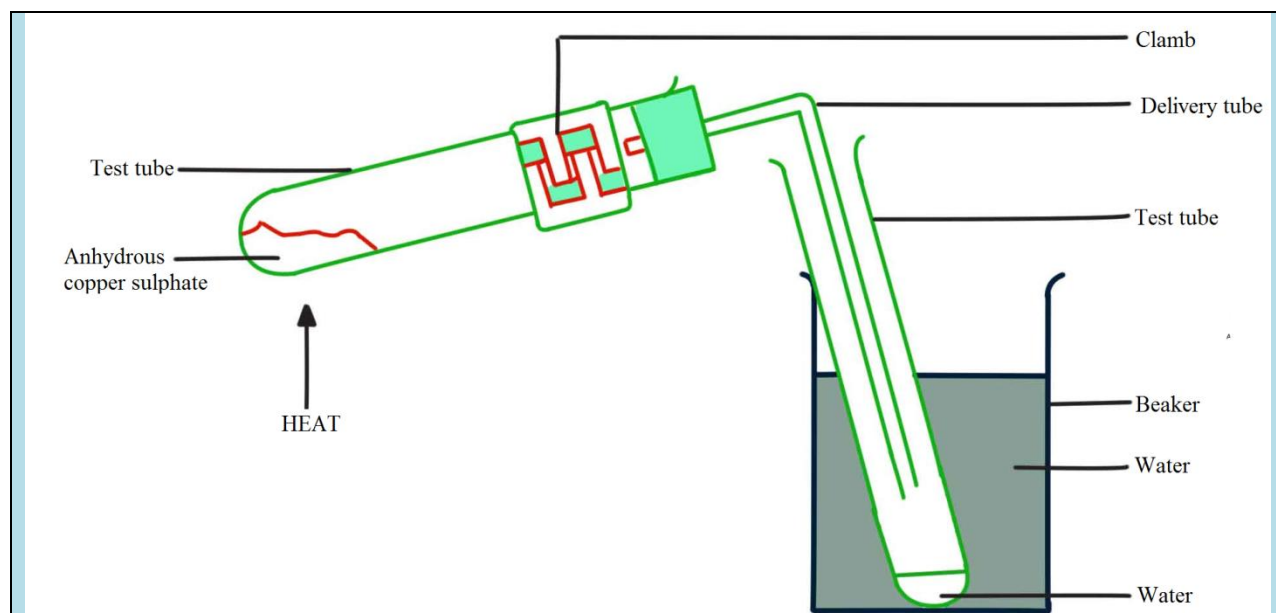

Activity questions

Record any observations made during the process and when the water was poured back onto the white copper (II) sulfate.

11.4.1. Reducing action of $\text{S}_2\text{O}_3^{2-}$

The thiosulfate anion reacts stoichiometrically with iodine in aqueous solution, reducing it to iodide as it is oxidized to tetrathionate:

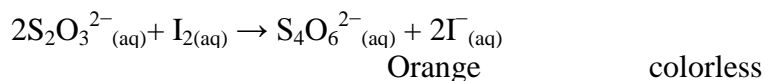

Thiosulfate ion reduces Iron (III) to iron (II) according to the following equation:

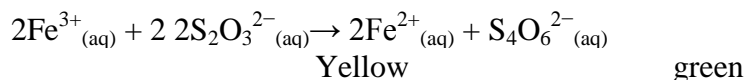

Thiosulfate ion is also used in analytical chemistry. It can, when heated with a sample containing aluminium cations, produce a white precipitate:

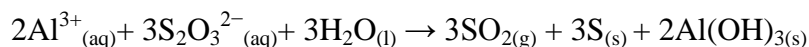

11.4.2. Reaction OF SO_3^{2-} with acids

The sulphites of Na^+ , K^+ , and NH_4^+ are soluble in water. Most of other sulphites are insoluble in water. However, due to the basic nature of SO_3^{2-} , all sulphites dissolve in acidic solution.

In general, sulphite ion reacts with acids liberating sulphur dioxide according to the ionic equation:

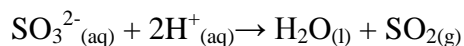

Examples:

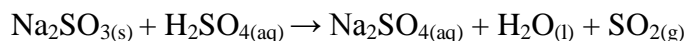

11.4.3. Action of heat on sulphates (SO_4^{2-})

The sulphates are normal salts of sulphuric acid and contain the sulphate ion, SO_4^{2-} . Soluble sulphates are prepared by action of dilute acid on the metal, metal oxide, metal hydroxide, metal carbonate or hydrogencarbonate:

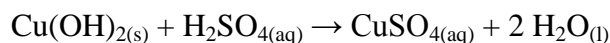
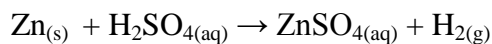

Insoluble sulphates (BaSO_4 and PbSO_4) are obtained by precipitation method:

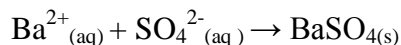

Most sulphate salts do not decompose on heating. For instance, sodium sulphate, potassium sulphate, and calcium sulphate are not decomposed by heat.

Only certain sulphate salts are decomposed by heat when heated strongly. On heating, some sulphates decompose to give either sulphur trioxide or sulphur dioxide or both.

For instance, strong heating of green crystal iron (II) sulphate will release steam, sulphur dioxide, sulphur trioxide and leave behind a reddish solid iron (III) oxide residue. The steam released comes from the hydrated water of the crystallized salt:

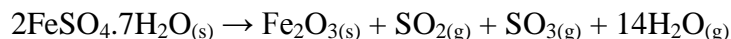

Zinc sulphate, copper (II) sulphate, and iron (III) sulphate decompose when heated strongly to produce sulphur trioxide gas and a metal oxide.

Examples:

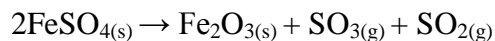
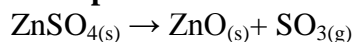

When ammonium sulphate is heated strongly, this white solid sublimate and is decomposed into ammonia gas and sulphuric acid vapour.

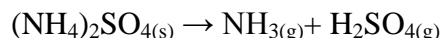

On heating, hydrated crystals of metal sulphates lose their water of crystallization and turn into a powder. They are then said to be anhydrous. Sometimes they may also lose their colour. Hydrated copper (II) sulphate is heated according to the following equation:

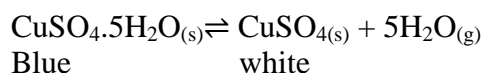

Checking Up 11.4

- Write equations to show how thiosulfate ions reduce the following substances:
 - Iodine
 - Iron (III) ion
 - Aluminium ion
- Write equations to show the action of heat on the following sulphates:
 - Zinc (II) sulphate
 - Iron (III) sulphate
 - Copper (II) sulphate
- When hydrated copper II sulphate solid is heated in a boiling tube, a white solid Q and droplets of a colourless liquid P are observed.
 - Identify substances; liquid P and solid Q.
 - Explain the observation above.
 - Explain what would be observed if water is added to white solid Q.

11.4. Identification of sulphite and sulphate ions

Activity 11.5

Given a substance **Y** which contains one cation and one anion, identify the cation and the anion in **Y**. Carry out the following tests on **Y** and record your observations and deductions in the table below.

Test	Observation	Deductions
a) Note the appearance of Y		
b) To one spatula of Y in a test tube add dilute nitric acid followed by aqueous barium nitrate		
c) Repeat the experiment using hydrochloric acid		

followed by aqueous barium chloride		
--	--	--

11.5.1. Identification of sulphate ion (SO_4^{2-})

a) Addition of barium nitrate solution

When an aqueous solution of Ba^{2+} ion is added to a solution containing SO_4^{2-} ion, a white precipitate of barium sulphate insoluble in dilute nitric acid is formed.

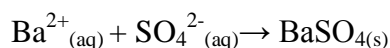

Use of barium chloride solution also gives a white precipitate insoluble in dilute hydrochloric acid. This reaction serves as the test for the sulphate ion in solution and also differentiates sulphate ions, SO_4^{2-} , from sulphite ions, SO_3^{2-} .

b) Addition of lead (II) nitrate solution

When an aqueous solution of Pb^{2+} is added to a solution containing SO_4^{2-} , a white precipitate of lead (II) sulphate is formed:

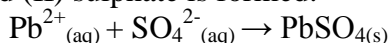

c) Addition of silver nitrate solution

When an aqueous solution of Ag^+ is added to a solution containing SO_4^{2-} , a white precipitate of silver sulphate:

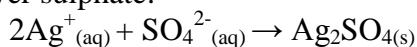

11.5.2. Identification of sulphite ion (SO_3^{2-})

To an aqueous solution of any sulphite, dilute nitric acid is added followed by a few drops of barium nitrates or barium chloride solution. A white precipitate of barium sulphite forms which dissolves in the nitric acid. The sulphite dissolves in acid with evolution of sulphur dioxide (seen as bubbles of a colourless gas). The sulphites give a white precipitate of barium sulphitesoluble in acid while sulphates give a white precipitate insoluble in acid.

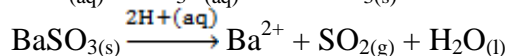
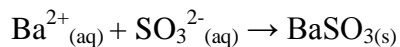

Checking Up 11.5

1. Describe a chemical test you would use to distinguish between the pairs of compounds below. In each case give the reagent, conditions if any and the expected observation.

a) BaSO_3 and BaSO_4

b) BaSO_4 and PbSO_4

2. The following deductions were made in an experiment carried out to identify the cation and anion in substance X. Use your notes to state the observations and deductions.

Test	Observation	Deduction
Note the appearance of X		
Dissolve one spatula end-full of X in 4cm ³ of water and divide the solution into 4 portions.		
i) To the 1 st portion add sodium hydroxide solution dropwise in excess.		
ii) To the 2 nd portion add aqueous ammonia dropwise in excess.		
iii) To the 3 rd portion add 2-3 drops of potassium iodide solution.		
iv) To the 4 th portion add acidified barium chloride solution		

11.5. Uses of group 16 elements and compounds

Activity 11.6

1. What are the most known applications of Group 16 elements?
 2. The following figures show how some elements play a big role in our daily lives. Observe carefully and answer the following questions:



- A** **B** **C** **D**
- What can you say about figure A, B, C and D?
 - Research in library or internet to find out the substance used in each of the figure.
 - Research in library or internet to find different uses of sulfuric acid.

11.6.1. Uses of oxygen

The first use of oxygen is in breathing and metabolism processes of all living organisms.

There are many other commercial uses for oxygen gas, which is typically obtained through fractional distillation of air. It is used in all operations involving combustion.

It is used in the manufacture of iron, steel, and other chemicals. Oxygen is also used as an oxidizer in rocket fuel, and for medicinal purposes. Mixture of oxygen and ethyne (oxyacetylene) is used for welding and metal cutting.

11.6.2. Uses of sulphur

The main use of Sulphur is the manufacture of sulphuric acid.

Sulphur is also used in vulcanization of rubber, a chemical process for converting natural rubber or related polymers into more durable materials by heating them with sulfur or other equivalent curatives or accelerators. These additives modify the polymer by forming cross-links (bridges) between individual polymer chains, making the final product very hard and resistant to pressure and other conditions.

Sulphur is an ingredient in the manufacture of dyes, fireworks and other sulphur compounds.

11.6.3. Uses of sulphuric acid

Sulphuric acid is a very important industrial chemical. It is used in the manufacture of hundreds of other compounds in many industrial processes.

- The bulk of sulphuric acid produced is used in the manufacture of fertilisers (e.g., ammonium sulphate, superphosphate).
- Sulfuric acid is also used in many other applications such as in: metallurgical industry, storage batteries, chemistry laboratories, etc....

11.6.4. Uses of hydrogen sulphide (H₂S)

Some nuclear power plants use hydrogen sulphide to produce heavy water. Farmers use H₂S as an agricultural disinfectant. In Analytical Chemistry, H₂S is used in selective precipitation of metal sulfides

Checking Up 11.6

1. Give at least 3 uses of oxygen
2. Mention three areas in which H₂SO₄ plays an important role
3. Briefly explain what is meant by “vulcanization”
4. What property makes sulphuric acid a dangerous corrosive product?
5. How do you proceed when you mix sulphuric acid with water

11.7. End unit assessment

Multiple choice questions

1. Which one(s) of the following substances is not easily soluble in water:
(A) H_2 (B) O_2 (C) SO_2 (D) CO_2
2. Select the molecular formula of sulphur in the following list:
(A) S (B) S_2 (C) S_4 (D) S_8
3. Choose the correct answer. All the elements of oxygen family are:
(A) Non - metal (B) Metalloids (C) Radioactive (D) All have allotropic forms
4. The triatomic species of element oxygen is known as:
(A) Azone (B) Polyzone (C) Trizone (D) Ozone
5. Which of the following acts as pickling agent:
(A) HNO_3 (B) H_2SO_4 (C) HNO_2
6. Which of the following is not suitable for use in desiccators to dry substance?
(A) Conc H_2SO_4 (B) Na_2SO_4 (C) $CaCl_2$ (D) P_4O_{10}
7. Which of the following methods are going to use to test presence of water in a liquid:
(A) Taste (B) Smell (C) Use of litmus paper (D) Use of anhydrous $CuSO_4$
8. When sulphur is boiled with Na_2SO_3 solution, the compound formed is:
(A) Sodium Sulphide (B) Sodium Sulphate (C) Sodium persulphate (D) Sodium thiosulphate

Short and long answer Open questions

9. State two ways in which oxygen differs from other group 16 elements.
10. State two sources and two uses of oxygen.
11.
 - a) Name two crystalline allotropes of sulphur.
 - b) Write equation to show how sulphur reacts with oxygen, iron and sulphuric acid.
 - c) Write two equations to illustrate the reducing property of hydrogen sulphide.
12. Sulphur is used to make sulphuric acid.
The reactions in the manufacture of sulphuric acid by the Contact Process are shown

Sulphur dioxide + oxygen	→	Sulphur trioxide
$2\text{SO}_2 + \text{O}_2$	reaction 2	2SO_3
Sulphur trioxide	→	Oleum
SO_3	reaction 3	$\text{H}_2\text{S}_2\text{O}_7$
Oleum + water	→	Sulphuric acid
$\text{H}_2\text{S}_2\text{O}_7$	reaction 4	H_2SO_4

below.

- Give a large scale source of the element sulphur
- State another use of sulphur dioxide
- How is sulphur changed into sulphur dioxide?
- Write a complete chemical equation for reaction 3.
- Write a chemical equation for reaction 4.

UNIT 12: TRENDS OF CHEMICAL PROPERTIES OF GROUP 17 ELEMENTS AND THEIR COMPOUNDS

Key unit Competence:

To be able to: Compare and contrast the chemical properties of the Group 17 elements and their compounds in relation to their position in the Periodic Table.

Learning objectives

By the end of this unit, I will be able to:

- Prepare and test halogens.
- Perform experiments to prepare and test chlorine, bromine and iodine.
- Relate the oxidizing power of Group 17 elements to their reactivity.
- Relate the acidity strength of oxoacids to the number of oxygen atoms combined with the halogen.
- Compare the reactions of the halogens with cold dilute sodium hydroxide and hot concentrated sodium hydroxide solutions.
- Describe the uses and hazards of halogens and their compounds.

Introductory Activity 12

- 1.a) Indicate any chemical products you know that contain elements of group 17.
b) Indicate where those compounds in 1.a) can be found and what they are used for?
2. Write the electronic configuration of fluorine and describe the type of ion it may form.
3. a) Predict between F and Cl which one has a higher electronegativity than another.
b) Explain your answer in 3.a)

12.1 Natural occurrence of halogens

Group 17 elements are called **halogens**. They include: Fluorine (${}^9\text{F}$), chlorine (${}^{17}\text{Cl}$), bromine (${}^{35}\text{Br}$), iodine (${}^{53}\text{I}$) and astatine (${}^{85}\text{At}$). Although astatine is a member of group 17 elements, its chemistry is of little importance in this unit because all of its known isotopes are radioactive. The longest-lived isotope of Astatine (At-210) has a half-life of only 8.3 hours. All these elements have 7 electrons in their outermost shell ($ns^2 np^5$) which is one electron short of the next noble gas.

Activity 12.1

A.Preparation of Cl_2 and I_2

1. Dissolve a small quantity of potassium iodide (2g) in a beaker containing 120 ml of water. Keep this solution.
2. Pour 20 ml of a 0.02 mole/litre potassium permanganate solution into a flat-bottomed flask.
3. Pour concentrated hydrochloric acid into potassium permanganate in the flat-bottomed flask (20 ml of a 2 mol/litre HCl).
4. Pour potassium iodide (10 ml of the potassium iodide solution) in the boiling tube.
4. Direct the delivery tube into a boiling tube containing potassium iodide solution as shown in the set-up diagram.
5. Heat the flask until there is a colour change in the boiling tube. Record the observations.
6. Add few drops of starch indicator to the resultant solution in the boiling tube
7. Record the observations.

B:Preparation of Br_2

8. Repeat procedures steps 1 to 7 but this time use solutions of KBr or NaBr instead of KI in the boiling tube.

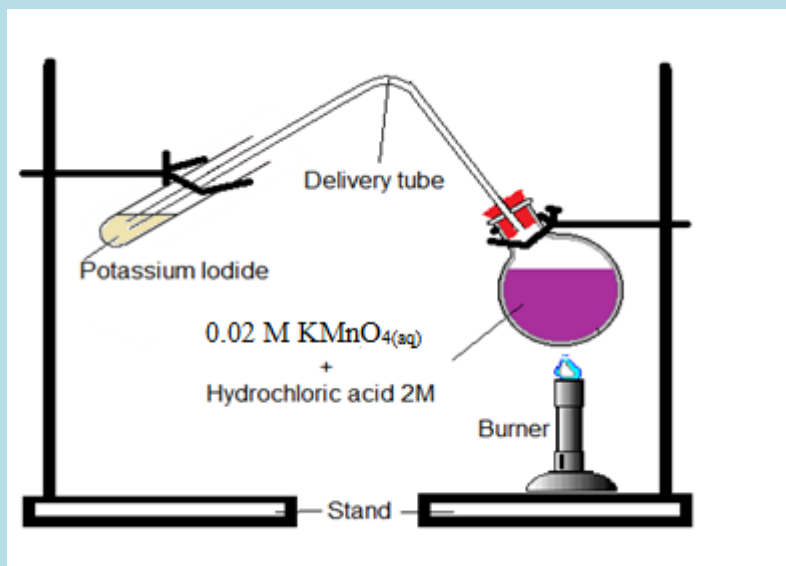

All halogens occur in sea water as halide ions. Halogens also occur in minerals such as, NaCl (rock salt), CaF_2 , $\text{Ca}(\text{PO}_4)_3\text{F}$ and NaAlF_6 . Chlorides also occur in the great salt lake and the Dead Sea, and in extensive salt beds that contain NaCl, KCl or MgCl_2 . Hydrochloric acid is present in the human stomach to help in the digestion process of food.

Bromine compounds occur in the Dead Sea and underground brines. Iodine compounds are found in small quantities in Chile saltpeter, underground brines.

The best sources of halogens (with the exception of iodine) are halide salts. It is possible to oxidize the halide ions to produce the diatomic molecules by various methods, depending on the ease of oxidation of the halide ion. Fluoride is the most difficult to oxidize, whereas iodide is the easiest.

Checking up 12.1

1. State 2 locations where chlorine can be found in nature.
2. Write the chemical formulae of the compounds of halogens in nature.
3. Give the name of one lake in Rwanda where salt is abundant in water.
4. Explain the separation method you can use to get the salt crystals from the water.
5. Fluoride ion is the most difficult to oxidise into fluorine, whereas iodide ion is the easiest. Explain why.

12.2. Extraction methods of halogens

Activity 12.2 (a): Preparation of chlorine gas and test the halogens formed

1. Put 0.5 gram of KMnO_4 in a round bottomed flask.
2. Pour concentrated HCl acid (5 ml of a 1 mol/litre) in round bottomed flask.
3. Connect the apparatus to a delivery tube using a rubber stopper.
4. Heat the HCl and KMnO_4 mixture.
5. Put a moist blue litmus paper on the outlet of the delivery tube as heating takes place.
6. Also insert the delivery tube in a boiling tube containing 4 ml of KI solution.
7. Pour 1 ml of the resultant solution from the boiling tube into a solution of starch indicator.
6. Note the observable changes.

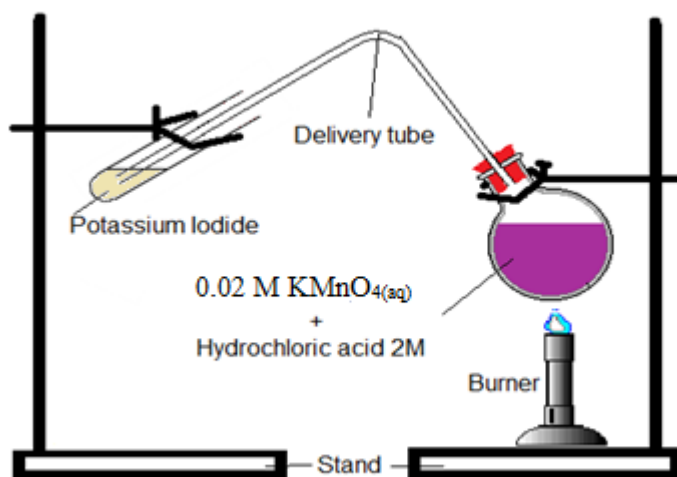

Activity 12. 2 (b): Preparation of bromine

1. Put 0.5 gram of MnO_2 in a round bottomed flask.
2. Pour concentrated NaBr solution (5 ml of a 0.1 mol/litre) in the round bottomed flask.
3. Pour 5 ml of 1 mol/litre HCl solution in the round bottomed flask mixture.
4. Connect the apparatus to a delivery tube using a rubber stopper.
5. Heat the round bottomed flask mixture.
6. Direct the delivery tube in a solution of AgNO_3 in a test tube.
7. Note the observable changes.

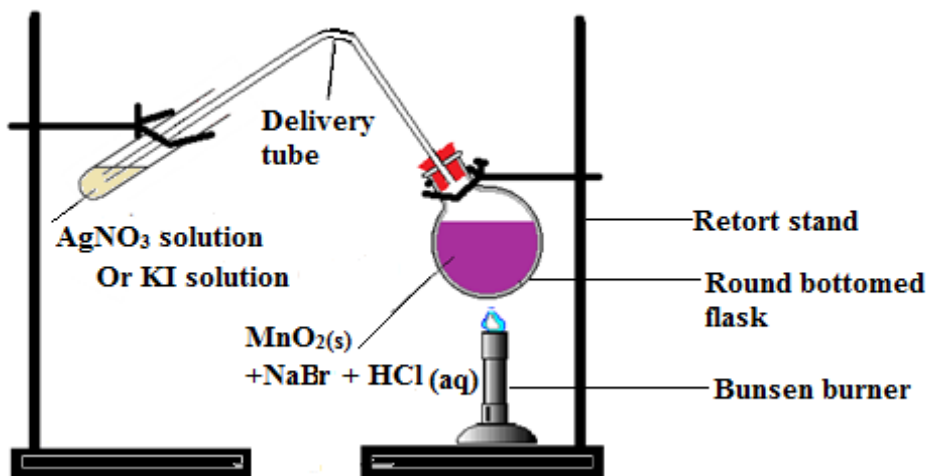

Activity 12.2. (c): Electrolysis of concentrated NaCl solution

- a) Put 1 g of NaCl in a beaker.
- b) Add water and stir using a glass rod until all the salt dissolves.
- c) Pour the solution in an electrolyser.
- d) Connect the electrolyser to the source of direct current and switch on.

- e) Dip a test tube full of water in the NaCl solution in inverted position from above each electrode.
 f) Put 2 a little phenolphthalein indicator in the solution under each test tube.
 g) Record the observations that take place for 5 minutes.

Apparatus set-up: Electrolysis of concentrated NaCl solution

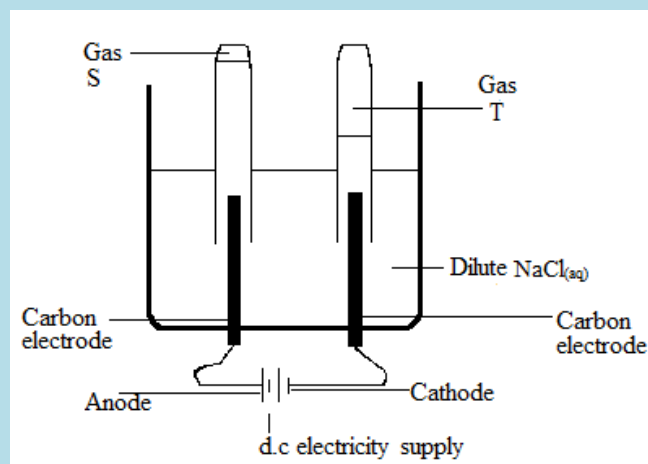

12.2.1. Chlorine

Most commercial chlorine is obtained by electrolysis of chloride ions in aqueous solutions of sodium chloride or molten NaCl.

The reactions that take place are shown by the following chemical equations:

At the anode: $2\text{Cl}^- \rightarrow \text{Cl}_2 + 2\text{e}^-$

At the cathode, reduction reaction that takes place depends on the state of NaCl:

If molten NaCl is used,

At the cathode: $2\text{Na}^+ + 2\text{e}^- \rightarrow 2\text{Na}$

Sodium can be collected in metallic form or dissolved in water to produce NaOH solution:

$2\text{Na} + 2\text{H}_2\text{O} \rightarrow 2\text{NaOH} + \text{H}_2$

If salt water or brine is used: hydrogen will form at the cathode, not sodium:

$2\text{H}^+(\text{aq}) + 2\text{e}^- \rightarrow \text{H}_2(\text{g})$

It is feasible to prepare chlorine, bromine and iodine in the laboratory by the chemical oxidation of the halide ion in acid solution with strong oxidizing agents such as manganese dioxide (MnO_2) or sodium dichromate ($\text{Na}_2\text{Cr}_2\text{O}_7$).

The reaction with manganese dioxide is represented by the equation given below:

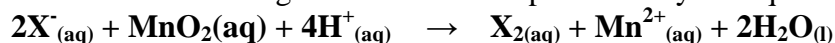

Where X= chlorine, bromine or iodine. The halide used here may be NaX or KX

12.2.2. Fluorine

The major method for preparing fluorine is electrolysis. The most common electrolysis procedure is to use a molten mixture of potassium hydrogen fluoride, KHF_2 , and anhydrous hydrogen fluoride. During the process, fluoride ion, F^- is oxidized to F_2 , whereas hydrogen ion, H^+ , is reduced to H_2 .

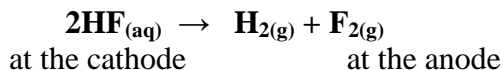

Electrolysis causes HF to decompose, forming fluorine gas at the anode and hydrogen at the cathode. The two gases are separated to prevent their explosive recombination to reform hydrogen fluoride, HF.

12.2.3. Bromine

The industrial production of bromine involves the oxidation of bromide ion by chlorine:

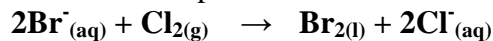

Chlorine is a stronger oxidizing agent than bromine.

12.2.4. Iodine

Iodine can be obtained by oxidation of iodide ions by chlorine gas or another halogen that is higher than iodine in the group.

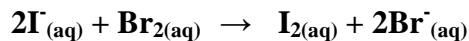

The industrial production of iodine is achieved using the reduction of sodium iodate, NaIO_3 . The reaction is carried out using sodium hydrogen sulfite, NaHSO_3 :



Checking up 12.2

1. Describe the preparation of chlorine in the laboratory.
2. How is electrolysis used to produce chlorine done industrially?
3. Explain the method used to produce bromine.
4. Explain the hazards that are encountered during the production of fluorine from its ores.
5. Say if the following statement is correct or wrong and justify your answer:
"Bromine can be produced by oxidation of bromide by chlorine and vice-versa".

12.3. Trends of physical and chemical properties of group 17 elements down the group.

Activity 12.3: Testing a few properties of halogens

1. Dissolve about 0.5g of sodium chloride crystals in a test tube containing 20cm^3 of water. Keep

this solution.

2. Pour 4 ml of the NaCl solution in 4 ml of a solution of conc H_2SO_4 in a test tube.
3. Heat the above mixture in (NaCl and H_2SO_4) on a Bunsen burner flame.
4. Test the gas evolved with blue and red litmus papers.
5. Repeat the above procedures but using NaBr instead of NaCl .
6. Repeat the above procedures but these times use KI instead of NaCl .
7. Test the presence of any evolved gas with litmus papers.
8. Test the resultant solution of the mixture of KI and concentrated H_2SO_4 with a solution of starch indicator.
7. Record the observations
8. Interpret the results of the reactions in the experiment and draw a conclusion of the reactions.

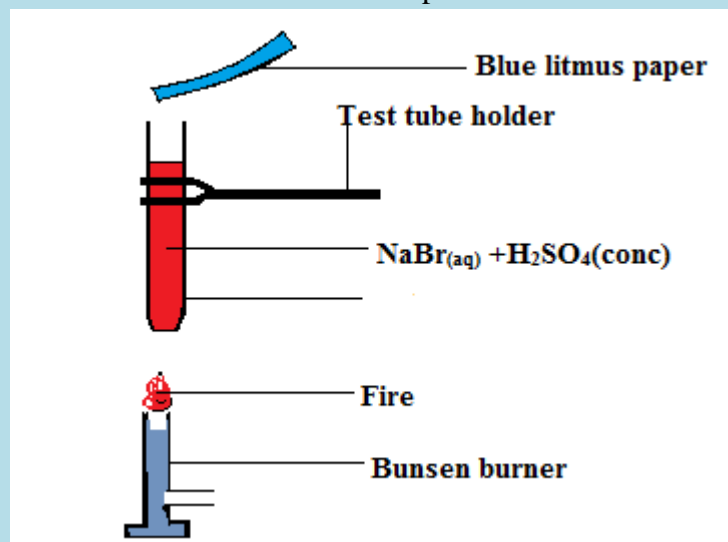

Observations:

The colourless solution of $\text{KI}_{(\text{aq})}$ turns red or reddish when chlorine gas is bubbled in it.

The red solution turns the colourless starch indicator solution to dark-blue.

On standing for a while, the solution settles down and gives a black residue.

Interpretations

Chlorine is liberated by the reaction between 2M hydrochloric acid and potassium permanganate solution. Chlorine displaces iodine from potassium iodide solution, which dissolves in water to give a dark-red solution, and turns starch indicator dark-blue. The greyish-black residue is due to the formation of Iodine solid.



12.3.1. Physical properties of group 17 elements down the group

a) Appearance

At room temperature and pressure, fluorine and chlorine are gases, bromine is a liquid and iodine is a solid. The table below shows the physical properties of halogens.

Table 12.1: Physical properties of halogens

Element	Fluorine	Chlorine	Bromine	Iodine
Atomic number	9	17	35	53
Boiling point ($^{\circ}\text{C}$)	-188	-34.5	59	183
Melting point ($^{\circ}\text{C}$)	-220	-101	-7	113
Colour/Appearance	Pale yellow	Greenish-yellow	Red-brown	Shiny-Black
Physical state at room temperature	Gas	Gas	Liquid	Solid

As shown in the table above, the boiling and melting points of halogens increase as you move down the group due to increase of the atomic mass which increases the strength of Van der Waals forces.

c) Solubility in water

- Fluorine and chlorine dissolve in cold water.
- Bromine and iodine are sparingly soluble in polar solvents like water and they form coloured solutions. However they are soluble in organic solvents like carbon tetrachloride, carbon disulphide and hydrocarbons.
- Halogen-halogen bond dissociation energy decreases from chlorine downwards as shown in the following trend:

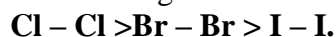

The reason why the trend is in this order is that in a smaller molecule such as Cl-Cl, the bond length is shorter so the internuclear attraction becomes bigger and therefore more energy is required to break the bond Cl-Cl.

- **Fluorine**, F_2 presents an exception because its energy of dissociation F-F is far smaller than that of Cl-Cl (opposite to the general trend from Cl_2 to I_2) because there is a repulsion between the lone pairs of electrons of fluorine atoms in the molecule due to the small size of fluorine.

12.3.2. Trend in chemical properties of group 17 elements down the group

Due to their valence electronic structure of $ns^2 np^5$ halogens gain easily one electron to complete the octet structure, that is why they exhibit an oxidation state (-1) in most of their compounds.

In addition to that, chlorine, bromine and iodine exhibit +1, +3, +5 and +7 oxidation states. The higher oxidation states is achieved when the halogen is in combination with a small and highly electronegative atom such as fluorine and oxygen. Example: Interhalogens, oxides and oxoacids. The oxidation states of +1, +5, +7 occur in the oxides and oxoacids of chlorine and bromine.

Compounds where halogens have positive oxidation states are generally very reactive, because they tend to be reduced to the oxidation state -1, the most stable oxidation state of halogens. Being the most electronegative element, fluorine exhibits only -1 oxidation state. All the halogens are highly reactive; they are the most reactive group of non-metals in the periodic table. They react with metals and non-metals to form halides. In Group 17 elements (halogens), the reactivity of halogens decreases down the group in the order: $F_2 > Cl_2 > Br_2 > I_2$. Hence each halogen displaces those below it from their salts.



Figure 12.1: Students carrying out chemistry experiment in Rwanda

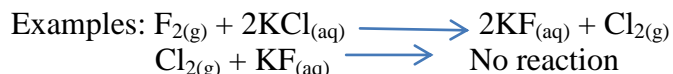

The ease of capturing an electron indicates the strength of oxidising nature of halogens. F_2 is the strongest oxidising halogen and it oxidises other halide ions in solution and even in the solid phase.

In general, a halogen oxidises halide ions of higher atomic number. The halogens decrease in strength of oxidising power as we descend the group.

a) Reactions of halogens with water

Fluorine exhibits anomalous behaviour in many properties. The anomalous behaviour of fluorine is caused by its small size and very high electronegativity.

Fluorine reacts vigorously with water to produce oxygen O_2 and hydrofluoric acid HF.

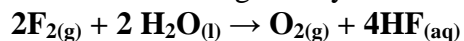

Chlorine dissolves slightly in water at room temperature ($25^\circ C$). At $80^\circ C$ and above, Cl_2 gas is insoluble in water.

Chlorine reacts with water to produce hydrochloric acid, HCl and hypochlorous acid, HClO:

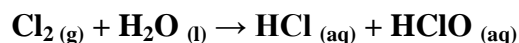

Hypochlorous acid is a bleaching agent.

Bromine dissolves in water; it reacts with water slowly to form hydrogen bromide HBr and hypobromous acid, HBrO:

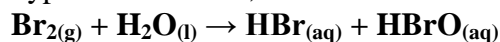

Solubility of iodine in water is very low. Iodine does not react with water.

Example: when a halogen is added to colourless solutions containing halide ions the following observations are made (Table 12.2).

Table 12.2: Comparison of oxidising power of halogens

Halogen	F ⁻ (aq)	Cl ⁻ (aq)	Br ⁻ (aq)	I ⁻ (aq)
F ₂ (g)	No change	Greenish solution = Cl ₂ (aq)	Red solution = Br ₂ (aq)	Red solution = I ₂ (aq)
Cl ₂ (g)	No change	No change	Red solution	Red solution
Br ₂ (l, aq)	No change	No change	No change	Red solution
I ₂ (s, aq)	No change	No change	No change	No change

b) Reaction of halogens with hydroxide:

-Cl₂ reacts with excess cold dilute OH⁻ and the reaction equation is:



With hot concentrated OH⁻, chlorate ClO₃⁻, is formed:



The same reactions occur for Br₂ and I₂.

-F₂, unlike other halogens, does not form oxosalts with alkalis and it does not form oxoacids as shown in the following reactions:

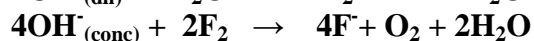
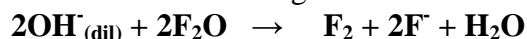

c) Reaction with metals:

Halogens react with metals to form salts, metal halides. Example: bromine reacts with magnesium to form magnesium bromide

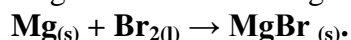

The preparation of certain anhydrous metal halides is effected using this method of reacting a halogen and a metal. Examples: MgCl₂ (white solid), AlCl₃ (white solid), FeCl₃ (brown solid), FeBr₃ (dark red solid) etc... are halides that can be prepared in this way.

Generally metal halides are ionic, the most ionic being the ones where the metal has low oxidation states (+1,+2).

For the same metal in the same oxidation state, the ionic character of the metal halides decreases down the group: MF > MCl > MBr > MI; whereby M is a monovalent metal.

If a metal exhibits more than one oxidation state, the halide in a higher oxidation state will be more covalent than the one with a lower oxidation state.

Example: SnCl_4 and PbCl_4 are more covalent than SnCl_2 and PbCl_2 respectively.

d) Reaction with non-metals

Halogens react with hydrogen gas to form hydrogen halides but the affinity for hydrogen decreases from fluorine to iodine.

Hydrogen halides dissolve in water to form hydrohalic acids. The acidic strength of these acids varies in the order: $\text{HF} < \text{HCl} < \text{HBr} < \text{HI}$.

The stability of these halides decreases down the group due to the decrease in (H-X) bond strength order: $\text{H-F} > \text{H-Cl} > \text{H-Br} > \text{H-I}$.

Halogens react with oxygen to form many oxides such as, Cl_2O , Cl_2O_6 , etc.. In those oxides, except for fluorine, halogens have positive oxidation states due to the high electronegativity of oxygen; this makes them unstable and very reactive.

Fluorine forms compounds with oxygen where it has a negative charge; they are rather oxygen fluoride; e.g. OF_2

With phosphorus, all halogens react with phosphorus to form phosphorus (III) halides of the form PX_3 .

The reaction equation of phosphorus with bromine is represented in a general equation as:

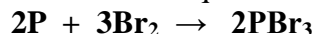

In excess chlorine or bromine, phosphorus reacts to form phosphorus (V) chloride or bromide:

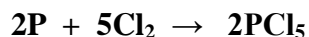

The reaction between phosphorus (III) chloride and phosphorus (V) chloride is reversible:



Halogens combine with other halogens to form various compounds known as **interhalogens** of the types XY , XY_3 , XY_5 and XY_7 , whereby X is a larger size halogen and Y is smaller size halogen. These compounds are easiest to form when Y is fluorine.

d) Bleaching property

Bleaching is the process of removing stains or colours in fabrics, especially by the use of chemical agents such as halogens of chlorine and bromine.

The bleaching action of chlorine is an oxidizing action of hypochlorous acid, HOCl :



The hypochlorous acid oxidizes the dye material to form a colourless substance.



Chlorine bleaches ordinary inks which are solutions of dyes.

Bromine has a similar action but with a much less vigorous action.

Iodine has no reaction with water and therefore it is not a bleaching agent.

12.3.3. Preparation of hydrohalic acids

Halogens form hydrogen halides (**HF_(g)**, **HCl_(g)**, **HBr_(g)** and **HI_(g)**), these hydrogen halides form a series of acids when they are dissolved in water. When in aqueous solution, the hydrogen halides are known as **hydrohalic acids**:

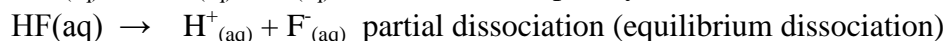

Hydrogen halides are formed by reacting a solid halide (such as NaBr) with concentrated phosphoric (V) acid (H₃PO₄):

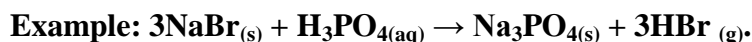

The hydrogen halides fume on contact with air and with moisture, they react to form acids:

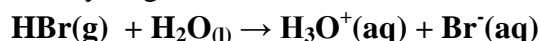

HF and HCl can be prepared by using concentrated sulphuric acid, H₂SO₄, a less expensive method:

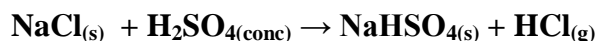

Similar equation for NaF.

Concentrated sulphuric acid is an oxidising agent and can't be used to prepare HBr or HI. It is observed that as HBr or HI are formed, they are oxidised by sulphuric acid:

HBr and HI are prepared by hydrolysis of phosphorus trihalides.

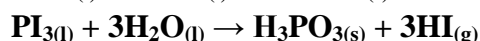
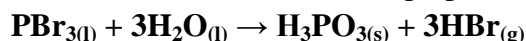

Checking up 12.3

1. State different hydrogen halides that can be formed.
2. What is the difference between hydrogen halides and hydrohalic acids?
3. Describe the anomalous behaviour of fluorine in the group (explain at least 3 differences from the rest of the halogens).
4. Write the reaction equation that takes place between:
 - a) Solid chloride with concentrated sulphuric acid.
 - b) Bromine in hot concentrated sodium hydroxide solution.
5. Briefly explain the trend in volatility of hydrogen halides as you move down the group.
6. Explain why the hydrogen halides acidity increases in the order: HF < HCl < HBr < HI
7. Explain the trend in solubility of halogens in water as you move down the group.
8. You have two test tubes; one contains water, the other contains a solution of chlorine in water, and you are asked to identify them. What test are you going to do in order to identify the two test tubes?

2.4. Trends in strength of acidity, volatility and reducing power of hydrogen halides

Activity 12.4

1. Pour 2 ml of hydrogen peroxide in a test tube.
2. Add 1 ml of 1 mol/litre solution of sulphuric acid to the H_2O_2 .
3. Add 1 ml of a solution of KI.
4. Repeat the steps 1 to 3 but this time using NaCl solution.
5. Note the observed changes for the case of KI and for NaCl solutions respectively.

12.4.1. Acid strength

The acid strength is a measure of how an acid dissociates in water into its ions. Strong acids dissociate completely into their ions, whereas a weak acid dissociates partially into its ions.

Examples:

- Hydrochloric acid is a strong acid: $\text{HCl}(\text{aq}) + \text{H}_2\text{O}(\text{l}) \rightarrow \text{H}^+(\text{aq}) + \text{Cl}^-(\text{aq})$ complete dissociation.
- Hydrofluoric acid is a weak acid: $\text{HF}(\text{aq}) + \text{H}_2\text{O}(\text{l}) \rightarrow \text{H}^+(\text{aq}) + \text{F}^-(\text{aq})$ partial dissociation

The acid strength of hydrogen halides (HX) increases down the group from HF to HI:



Because of the very high electronegativity of F, it forms very strong H-F bond. In water, it is slightly dissociated to give few H^+ ions in solution, therefore acidic strength is influenced by:

Bond energy: down the group, bond energy decreases. Thus the tendency to dissociates and form H^+ ions increases.

12.4.2. Volatility

Volatility is the state of having a low boiling point to evaporate easily.

The boiling points of hydrogen halides generally increase down the group. This is because the Van der Waals' forces increases with size (the forces increase with increase of the surface of contact between molecules).

The high electronegativity of fluorine atom is the root cause of the strong hydrogen bonds. It is liquid at room temperature while other hydrogen halides are gases.

The trend in volatility: $\text{HCl} > \text{HBr} > \text{HI}$.

HCl (Bpt = -85°C) is more volatile than HBr (B.pt = -66.7°C) and HBr is more volatile than HI (Bpt = -35.4°C)

HF is an exception to the general trend (it has a high boiling point of 19.9°C). It is almost liquid at room temperature while the rest are gases because there are strong hydrogen bonds between HF molecules.

12.4.3. Reducing power

The reducing power of hydrogen halides is dependent on the ability of their anions (halide ions) to liberate electrons.

It becomes easier to oxidise the hydrogen halides as we go down the group because the electron on the halide ion becomes less attracted to the nucleus as we move down the group.

Hence the order of reducing power is: $I^- > Br^- > Cl^- > F^-$

Given that halogens are the best oxidizing agents since they tend to capture electrons from other elements to achieve the octet electronic configuration, the halide ions are not expected to be good reducing agents.

However, an iodide ion, due to its big size, can easily liberate an electron and therefore act as a mild reducing agent.

Hence **HI** is the strongest reducing agent of all hydrogen halides.

HI can reduce Cl_2 , Br_2 , O_2 , Fe^{3+} salts, etc... to produce molecular iodine, I_2 :

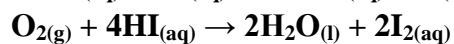
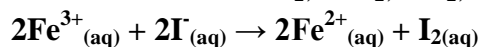

Therefore when a colourless aqueous solution of HI is exposed to air, it turns brown because of the presence of I_2 .

Concentrated H_2SO_4 oxidises Br^- and I^- to form Br_2 and I_2 elements respectively.

Concentrated H_2SO_4 cannot oxidise F^- and Cl^- ions.

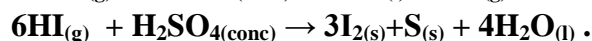
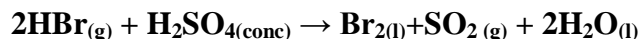

Checking up 12.4

1. Explain why fluorine is the most oxidising element in group 17 and of all chemical elements?
2. Explain why the acidity of group 17 hydrohalides increases down the group.
3. Explain why HF does not follow the general trend of volatility but instead it has a higher boiling point than HCl.
4. Describe the natural state and appearance of halogen elements at room temperature and pressure.
5. You have two unknown sample solutions A and B. You are told that one is a solution of $NaCl(aq)$, the other is a solution of $NaI(aq)$. You are asked to identify them. When you add a solution of $Fe^{3+}(aq)$ which has a yellow colour, to both sample solutions, you get the following results:
 - (a) Adding $Fe^{3+}(aq)$ to A gives a yellow solution;
 - (b) Adding $Fe^{3+}(aq)$ to B gives a solution with a complicated mixture of colours between green and violet.

Question: Which solution is in A, which solution is in B? Justify.

12.5. Chemical properties of chlorates, iodates, perchlorates and periodates

Activity 12.5 (a)

1. Put 0.5g of solid KClO_3 in a pyrex test tube.
2. Using a test tube holder, heat the KClO_3 strongly while placing a glowing splint on the test tube outlet.
3. Note the observation as heating takes place.
4. Dissolve a small portion of the solid residue in water.
5. Put a little solid residue in 1 ml of aqueous solution of AgNO_3 .
6. Record the observed changes.
7. Deduce the chemical changes that took place.
 - a) While heating
 - b) On adding the residue to AgNO_3 solution.
8. Write the equations for the reaction that took place in 7 (a) and 7(b).

Activity 12.5 (b)

1. Dissolve 0.5g of KIO_3 solid in water and make 20 ml of solution.
2. Add 20 ml of a 1mol/litre solution of HCl acid to the solution of KIO_3 .
3. Pour 2 ml of the above mixture in a test tube.
4. Add 1 ml of a solution of KI to the solution containing KIO_3 and HCl acid.
5. Note down the changes observed.
6. Identify the reagent compound that is oxidizing and the one that is reducing in the above reactions.

Due to the high electronegativity and small size, fluorine forms only **one** oxoacid, **HOF** known as fluoric (I) acid or **hypofluorous acid**. Other halogens form many oxoacids. Most of them cannot be isolated in pure state. They are stable only in aqueous solutions or in the form of the salts.

Halogens normally form 4 series of oxoacids, namely: Hypohalous acids (HXO), halous acids (HXO_2), halic acids (HXO_3) and perhalic acids (HXO_4).

The difference between oxoacids is the oxidation state of the halogen in each oxoacids or halates.

Table 12.3: Oxohalic acids

Oxidation state of halogen and name		Chlorine	Bromine	Iodine	Thermal stability and acid strength	Oxidising power
+1	Hypohalous acid	HClO	HBrO	HIO	Increases ↓	Increases ↓
+3	Halous acid	HClO ₂	HBrO ₂	HIO ₂		
+5	Halic acid	HClO ₃	HBrO ₃	HIO ₃		
+7	Perhalic acid	HClO ₄	HBrO ₄	HIO ₄		

a) Acid character

In any arrangement of oxoacids of halogens, the first member has a high acidic properties from chlorine to iodine. This is because of the small size and high electronegativity of the particular halogens.

For example: Amongst halic acids, chloric acid has the highest acidity.

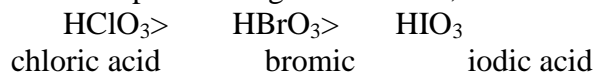

The acidity of oxoacids increases with increase in the oxidation state of the halogen.

Example: Among of the four oxoacids of chlorine, the acidity increases from hypohalous acid to perchloric acid.

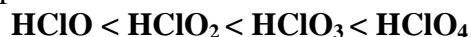

Explanation: The acidity increases with the number of oxygen atoms forming bonds with the halogen atom. The greater the number of oxygen atoms, the greater the acidity becomes.

Conclusion: The strongest of all the halogen oxoacids is the perchloric acid.

b) Oxidising power of oxoacids:

The oxidizing power of these acids increases as the oxidation number increases, i.e.



Perhalates are strong oxidizing agents, the oxidizing power is in the order:



Thus IO_4^- is the weakest oxidizing agent, and ClO_4^- is the strongest.

Stability of oxoacids of chlorine in the increasing order is:

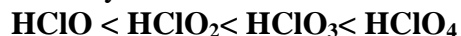

Acidity increases with increase in the number of oxygen atoms of the oxoacid.

The increasing stability order of anions of oxoacids of chlorine is:

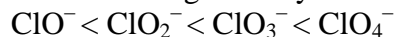

c) Thermal stability of halates

For different halogens having the same oxidation number, the thermal stability decreases with increase in atomic number i.e., it is in the order:

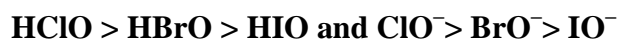

Potassium chlorate decomposes at 400°C to give potassium perchlorate and potassium chloride.



At higher temperatures, the perchlorate decomposes to give the chloride and oxygen.

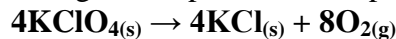

Potassium bromate and iodate give similar products on strong heating. No perbromate and periodate is formed during the heating.

The halates are also strong oxidizing agents as their corresponding acids behave. Potassium chlorate (V) oxidizes hot concentrated hydrochloric acid to an explosive bright yellow gaseous mixture.

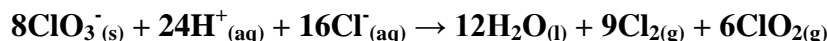

Checking up 12.5

1. Explain the trend in oxidizing power of oxoacids.
2. Indicate 1 importance of the decomposition of potassium chlorate, KClO_3
3. Write the equation for the decomposition of KClO_3 solid.
4. Write the reaction equation that takes place between KI , KIO_3 and HCl .

e) Tests for halide ions in aqueous solution

Table 12.4: Test of substance X with an unknown anion

Activity 12.5 (c)		
Identification of ions:		
i) You are provided with a solution of X substance.		
ii) Put 1 ml of X solution in each of the 4 test tubes.		
iii) Add in each test tube the reagent solutions as indicated in the table below.		
iv) Note down the observations for interpretation later in each test.		
Reagent + Substance X	Observation	Conclusion
a) $\text{X}_{(aq)} + 1\text{ml AgNO}_3$ solution and add $\text{NH}_3_{(aq)}$ until in excess	Pale yellow precipitate is formed which is insoluble in excess of NH_3 solution	
b) $\text{X}_{(aq)} + 1\text{ ml KIO}_{3(aq)} + 1\text{ ml KI}_{(aq)}$	Red solution is formed	
c) $\text{X} + 1\text{ml Pb}(\text{NO}_3)_2$ solution	Yellow precipitate formed	
d) $\text{X} + 1\text{ml conc H}_2\text{SO}_4$ solution	Red solution is formed	

Halide ions are detected by precipitation reactions using silver nitrate solution AgNO_3 or lead (II) nitrate $\text{Pb}(\text{NO}_3)_2$. The ionic equations below illustrate the general equation reactions:

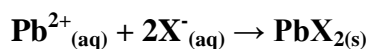
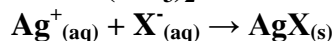

(whereby: X is Cl, Br or I)

f) Tests using AgNO₃ and ammonia solution, NH₃

The first step is to dissolve 1 ml of the compound to be tested in about 2 ml of dilute nitric acid.

The table given below shows the observable changes when we add the silver nitrate solution, AgNO_{3(aq)}, followed by ammonia solution, NH_{3(aq)}.

The addition of NH₃ ammonia solution is called ‘confirmatory test’, i.e. to confirm the first one.

Table 12.5: Tests of halides

Halide	AgNO ₃ solution	Effect of adding NH ₃ solution
Fluoride	Soluble solution	Soluble solution
Chloride	White precipitate	Disappearance of the white precipitate and formation of clear solution
Bromide	Cream precipitate	Cream precipitate dissolves in excess NH₃ solution
Iodide	Yellow precipitate	Yellow precipitate remain seven in excess NH₃ solution

If the test uses Pb²⁺_(aq) and Cl⁻ ions, heating the precipitate, it will dissolve; PbCl_{2(s)} is insoluble in cold water, but soluble in hot water.

g) Lead nitrate Pb(NO₃)₂ solution

Chloride, Cl⁻ ions: A white precipitate solution is formed in cold water, the precipitate dissolves when it is hot.

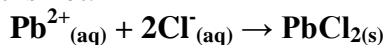

Bromide, Br⁻ ions: A cream precipitate is formed.

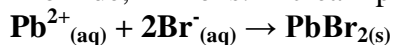

Iodide, I⁻ ions: A bright yellow is precipitate is formed.

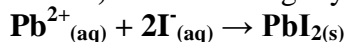

Checking up 12.5 (b)

1. You are given 1ml of solution Y in which you add 1 ml of AgNO₃ solution and there is formation of a white precipitate that dissolves on adding 1 ml of ammonia solution.

Deduce the anion present in solution Y.

2. Write a balanced equation for the reaction of:

a) Decomposition of KClO₄

b) Oxidation of Cl⁻ by ClO₃⁻ in acid medium.

3. Explain how ClO₃⁻ is prepared in the laboratory from chlorine.

4. Explain why fluorine forms only 1 oxoacid (HFO).

12.6. Uses of halogens and their compounds

Activity 12.6

1. When you want to eat food, salt is dissolved in it. Indicate the chemical composition of table salt and its natural occurrence.
2. Chlorine compounds are used in the treatment of water. Explain how chlorine reacts to be a good disinfectant in water treatment.
3. a) Write the observations of the phenomenon that takes place when electrolysis of a concentrated solution of chlorine is carried out in the laboratory.
b) Deduce the product of reaction that is formed at the anode.

12.6.1. Uses of Halogens

Halogens and their compounds have many applications and uses in different domains:

- Fluorine is used in production of synthetic fibres. It is also used as an ingredient in toothpastes as well as in the manufacture of HF.
- NaCl is the main food seasoning table and kitchen salt; it is also used in many industrial processes such as: NaOH production, soap manufacturing, etc...
- Chlorine is used to synthesise products for bleaching clothes, papers, etc. it is used as an antiseptic and as fungicide.
- Chlorine is used in water treatment as well as in the manufacture of plastics.
- Chlorine is used to make DDT (Dichlorodiphenyltrichloroethane: a banned chemical), and other chlorinated aromatic compounds used as pesticides.
- A Chlorine compound, HCl is important in in the human stomach for digestion.
- Halogen elements are used to manufacture polymers.
- Bromine is used in photographic industry (film manufacture).
- Iodine is used in food in form of iodised salt and in drugs to fight against goitre to kill bacteria in wounds, etc.

12.6.2. Hazards caused by group 17 elements

Bromine effects

- On heating, toxic fumes are formed.
- Reacts violently (explosively) with many compounds.
- Attacks plastics, rubber and coatings.

Chlorine effects

- It reacts violently with many compounds like ammonia to cause fire and explosion.
- It attacks many metals in the presence of water.
- It attacks plastics, rubber and coatings.

Chlorine oxide effects

- It may explosively decompose when it encounters shock and friction then it may explode on heating.
- It reacts violently with mercury, phosphorus, sulphur, etc causing fire and explosion hazard.

Fluorine effects

- It reacts violently with water to produce toxic and corrosive vapours: ozone and hydrogen fluoride.
- It reacts violently with ammonia, metals, oxidants, etc, to cause fire and explosion.

Hydrogen bromide effects

- It reacts violently with strong oxidants and many organic compounds to cause fire and explosion.
- It attacks many metals forming flammable hydrogen gas.

Hydrogen fluoride effects

- It reacts violently with many compounds causing fire and explosion.
- On contact with air, it emits corrosive fumes which are heavier than air.
- It attacks glass and other silicon-containing compounds.

SF6 effects

- The substance decomposes in a fire to produce toxic fumes of sulphur oxides and hydrogen fluoride
- When it is heated, there is formation of toxic fumes.
- CFCs (**chlorofluorocarbons**), is a global issue. These compounds of halogens destroy the Ozone layer.

Checking up 12.6

1. Indicate at least 3 uses of chlorine compounds in daily life.
2. State at least 2 uses of bromine and its compounds in daily life.
3. Why do we use iodised salt as table and cooking salt?
4. Discuss the importance of halogen compounds in biological processes in nature.
5. Give at least 2 applications of halogens or their products in industry.

12.7. End of unit assessment

1. Chlorine is used in the preparation of bleaching agents and iodine.
 - (a) (i) Write the products of the bleaching agent of chlorine when it reacts.
 - (ii) Determine the change in oxidation number of chlorine during the bleaching process (reaction).
- (b) Iodine is extracted from seawater by oxidising dissolved iodide ions with chlorine gas.

- (i) Write the ionic equation for this reaction.
(ii) Explain why chlorine is strong oxidising agent compared to bromine

2. Aqueous silver nitrate can be used as a test for halide ions. A student decided to carry out this test on a solution of magnesium chloride. The bottle of magnesium chloride that the students used showed the formula $\text{MgCl}_2 \cdot 6\text{H}_2\text{O}$. The student dissolved a small amount of $\text{MgCl}_2 \cdot 6\text{H}_2\text{O}$ in water and added aqueous silver nitrate solution.

- a) What would the student expect to see after adding aqueous silver nitrate?
b) Write an ionic equation for this reaction. Include state symbols.

Using aqueous silver nitrate, it is sometimes difficult to distinguish between chloride, bromide and iodide ions.

What test are you going to use to distinguish between them? Explain

Domestic tap water has been chlorinated before delivery to our faucets/taps. Chlorine reacts with water as shown below

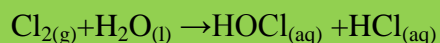

- (i) State the oxidation number of chlorine atom in Cl_2 , HOCl and HCl
(ii) When carrying out halide test with aqueous silver nitrate, it is important that distilled water is used for all solutions, rather than tap water.

Suggest why it is done this way.

3. Chlorine can be prepared by reacting concentrated hydrochloric acid with manganese(IV) oxide.

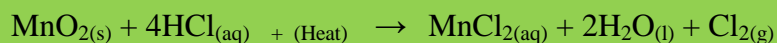

A student reacted 50cm^3 of 12mol dm^{-3} hydrochloric acid with excess of manganese (IV) oxide at room temperature and pressure.

Calculate the number of moles of HCl that reacted.

Calculate volume of $\text{Cl}_{2(\text{g})}$ produced, in dm^3 . (At room temperature and pressure, one mole of $\text{Cl}_{2(\text{g})}$ occupies 24dm^3) Chlorine gas is bubbled through an aqueous solution of bromide ions and also through an aqueous solution of iodide ions. What will be observed? Explain the observation by chemical equations

B/ Sodium metal reacts with chlorine gas to form the ionic compound, sodium chloride, NaCl . An organic solvent is then added and each mixture is shaken. .

I State what you would observe in each case

- ii) Write an equation for any chemical reactions that take place

State and explain the trend in reactivity shown by these observations

5 A student carried out experiments using chlorine gas (Cl_2)

- (a) In the first experiment, the student bubbled chlorine through aqueous solution of potassium bromide, $\text{KBr}_{(\text{aq})}$. A reaction took place. Give an explanation for that reaction.

(i) Write an equation of this reaction.

(ii) What colour of the solution after the reaction has taken place?

Explain why chlorine has a stronger oxidising power than bromine.

The equation for this reaction is shown below: $\text{Cl}_{2(g)} + 2\text{NaOH}_{(aq)} \rightarrow \text{NaCl}_{(aq)} + \text{NaClO}_{(aq)} + \text{H}_2\text{O}_{(l)}$

(c) In the third experiment, the student repeated the procedure in

(b) but with hot concentrated sodium hydroxide. A different reaction took place in which sodium chlorate (V) was formed instead of NaClO.

Write the equation for the reaction to produce sodium chlorate (V).

UNIT 13: PROPERTIES AND USES OF GROUP 18 ELEMENTS AND THEIR COMPOUNDS

Key unit competence: Compare and contrast the properties of the group 18 elements in relation to their position in the periodic table.

Learning objectives

By the end of this unit, I will be able to:

- State the physical properties of the Group 18 elements.
- Explain the lack of reactivity of the group 18 elements.
- Associate chemical inertia of the group 18 elements to their full valence shell.
- Recognize the importance of noble gases or group 18 elements in the daily life.

Introductory activity

Do you know any application of one or more noble gases?

If yes, where is it applied?

Electronic configuration of noble gases

He(Z=2) $1s^2$

Ne(Z=10) $1s^2 2s^2 2p^6$

Ar(Z=18) $1s^2 2s^2 2p^6 3s^2 3p^6$

Kr(Z=36) $1s^2 2s^2 2p^6 3s^2 3p^6 4s^2 3d^{10} 4p^6$

Xe(Z=54) $1s^2 2s^2 2p^6 3s^2 3p^6 4s^2 3d^{10} 4p^6 5s^2 4d^{10} 5p^6$

Rn(Z=86) $1s^2 2s^2 2p^6 3s^2 3p^6 4s^2 3d^{10} 4p^6 5s^2 4d^{10} 5p^6 6s^2 4f^{14} 5d^{10} 6p^6$

Group 18 consists of six elements: **helium**(${}^2\text{He}$), **neon**(${}^{10}\text{Ne}$), **argon**(${}^{18}\text{Ar}$), **krypton**(${}^{36}\text{Kr}$), **xenon**(${}^{54}\text{Xe}$) and **radon**(Rn). They are all gases and are characterized by filled s and p valence orbitals (valence electron configuration of $2s^2$ for helium and $ns^2 np^6$ for the others). This structure has been qualified as "the octet electronic structure"; octet means eight. This electronic structure, also called octet rule gives stability to the elements of Group 18.

Because of this, these elements are very unreactive. They form very few compounds. Because of this they are termed **noble gases**.

Other chemical elements tend to react, to combine with other elements or with themselves in order to fulfill the octet rule, i.e. to acquire the same electronic structure as the nearest noble gas.

13.1. Occurrence and physical properties of noble gases

Activity 13.1

The air is composed of a mixture of gases including water vapour.

-Do a research (with Zany documentation) to identify its components and arrange them according to their abundances (Comp1> Comp2, etc...)

-Show how each component can react with another or water vapour if possible.

-If not possible, justify your answer.

-If possible, identify the required condition for each process

-Explain how neon lamp works.

13.1.1. Occurrence

- All the noble gases except radon occur in the atmosphere. Their total atmospheric abundance in air is 0.03%; argon is the major component.
- Helium and sometimes neon are found in minerals of radioactive origin e.g., pitchblende, monazite, cleveite.
- Xenon and radon are the rarest elements of the group. Radon is obtained as a decay product of ^{226}Ra .

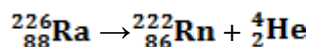

13.1.2. Physical properties

- All the noble gases are monoatomic.
- They are colourless, odourless and tasteless.
- They are sparingly soluble in water.
- They have very low melting and boiling points.
- Due to stable electronic configuration these gases exhibit very high ionisation energy. The ionization energy decreases down the group with increase in atomic size.
- Since they have stable electronic configurations, they have low tendency to accept or give up electron.

Note: Helium has the lowest boiling point of any known substance.

Checking up 13.1

Question: (i) Using dot and cross diagram, show how neon ($z=10$) is considered as a noble gas.

(ii) Why do we classify helium in Group 18?

13.2. Reactivity and inertness of noble gases

Activity 13.2

1. Through a research, can you find any compound made of one of the rare gas?
2. Do you think that noble gases can react with one of these reagents?
 - a)O₂
 - b)HCl
 - c)NaOH

Although group 18 elements used to be called inert gases, it has been discovered that some of them, in appropriate conditions can react and form compounds.

But up to now, of the group 18 elements, only krypton and xenon have been shown to form chemical compounds. The first of these was prepared in 1962 by Neil Bartlett, an English chemist who made the ionic compound **XePtF₆**, which contains the ions Xe⁺ and PtF₆⁻:

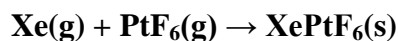

Red/Yellow-Orange

It has also been discovered that xenon tetrafluoride can be prepared by reacting xenon and fluorine gas in a nickel reaction vessel at 400°C and 6 atmospheres:

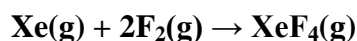

Xenon tetrafluoride forms stable colorless crystals. Two other xenon fluorides, XeF₂ and XeF₆, were synthesized by the group of Argonne, and a highly explosive xenon oxide (XeO₃) was also found. The xenon fluorides (XeF₂, XeF₄ and XeF₆) are colourless crystalline solids and sublime readily at about 25°C. They are powerful fluorinating agents.

They are readily hydrolysed even by traces of water, for example:

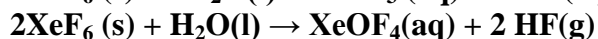
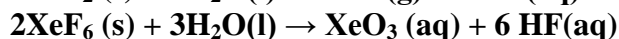
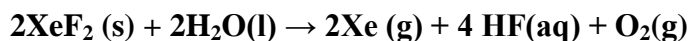

In the past years other xenon compounds have been prepared, for example, **XeO₄** (explosive), **XeOF₄**, **XeOF₂**, and **XeO₃F₂**. These compounds contain discrete molecules with covalent bonds between the xenon and the other atoms. A few compounds of krypton, such as **KrF₂** and **KrF₄**, have also been observed.

There is evidence that radon also reacts with fluorine, but the radioactivity of radon makes its chemistry very difficult to study.

Checking up 13.2

Question: Explain the danger which is avoided when helium is used in the air balloons.

13.3. Discovery of first noble gas compound and uses of noble gases

Activity: 13.3

Do a research (with any documentation) to find how each noble gas has been discovered and its uses?

Before 1960, Group 18 elements were considered as inert and were called inert gases. By 1960, no compound of a noble gas had yet been synthesized. The first published report, in June 1962, of a noble gas compound was by Neil Bartlett who noticed that the highly oxidising compound, platinum hexafluoride, PtF_6 , oxidized O_2 to O_2^+ . As the ionisation energy of O_2 to O_2^+ (1165 kJ mol^{-1}) is nearly equal to the ionisation energy of Xe to Xe^+ (1170 kJ mol^{-1}), he tried the reaction of Xe with PtF_6 . This yielded a crystalline product, xenon hexafluoroplatinate, whose formula was proposed to be $\text{Xe}^+[\text{PtF}_6]^-$. It was later shown that the compound is actually more complex, containing both XeFPtF_5 and $\text{XeFPt}_2\text{F}_{11}$. Nonetheless, this was the first real compound of any noble gas.

The first binary noble gas compounds were reported later in 1962. Neil Bartlett synthesized Xenon tetrafluoride (XeF_4) by subjecting a mixture of xenon and fluorine to high temperature. Rudolf Hoppe, among other groups, synthesized xenon difluoride (XeF_2) by the reaction of the elements.

Following the first successful synthesis of xenon compounds, synthesis of krypton difluoride (KrF_2) was reported in 1963.

From those discoveries, it was suggested that Group 18 would not be qualified as inert gases; better to call them “**noble or rare gases**”.

13.4. Uses of noble gases

Helium

- Helium is a non-inflammable and light gas. Hence, it is used in filling balloons for meteorological observations.
- It is also used in gas-cooled nuclear reactors.
- Liquid helium (B.P: -267.8°C) finds use as cryogenic agent for carrying out various experiments and conservation at very low temperatures.

Neon

- ❖ *Neon is used in advertising signs, it glows when electricity is passed through it. Different coloured neon lights can be made by coating the inside of the glass tubes with colored chemicals.*
- ❖ *Neon bulbs are more used in our daily life.*



Figure 13.3: Neon lamp

Argon

- It is used in light bulbs. The very thin metal filament inside the bulb would react with oxygen and burn away if the bulb were filled with air instead of argon.
- Argon is used mainly to provide an inert atmosphere in high temperature metallurgical processes (arc welding of metals or alloys).
- It is also used in the laboratory for handling substances that are air-sensitive.

Krypton

Krypton is used in lasers. Krypton lasers are used by surgeons to treat certain eye problems and others. It is used in light bulbs designed for special purposes.

Xenon

Xenon is used in fluorescent bulbs, flash bulbs and lasers. Xenon emits an instant, intense light when present in discharge tubes. This property of xenon is utilized in high-speed electronic flash bulbs used by photographers.

Radon

Radon is radioactive and is used in medicine as a source of gamma rays. The gas is sealed in small capsules, which are implanted in the body to destroy malignant (e.g., cancerous) growths.

Checking up 13.3

Question:

Match the name of element to the corresponding use.

- | | |
|------------|-------------------------------------|
| 1. Helium | a. Fluorescent lamp |
| 2. Neon | b. Used in laser |
| 3. Argon | c. Filling balloons |
| 4. Krypton | d. Coating the lamp glass tube |
| 5. Xenon | e. Protects the thin metal filament |

2. (i) There was a time where hydrogen was used for filling balloons; helium is now preferred, explain why.

(ii) When and why do some clinical treatments or research laboratories use rare or noble gases in their operations?

13.5. End unit assessment

1. a) Give a reason why the first ionization energies of noble gases are very high.
b) State one use of neon and give a reason to support your answer.
c) State and explain the trend in atomic radius among noble gases.
d) Why are noble gases unreactive?
e) Explain why the value of the first ionisation energy of neon is higher than that of sodium.
2. Explain why Group 18 elements are rare on Earth?
3. The discovery of compounds of noble gases has been done, up to date, with Xe and Kr, not with He or Ne. Can you suggest a probable reason?

UNIT 14: TRENDS IN CHEMICAL PROPERTIES OF PERIOD 3 ELEMENTS AND THEIR COMPOUNDS

Key unit competency: Compare and contrast the properties of the Period 3 elements and their compounds in relation to their positions in the Periodic Table.

Learning objectives:

By the end of this unit I will be able to:

- Compare the physical properties of the Period 3 elements.
- Describe the nature of the oxides of the Period 3 elements and the type of bonding in their chlorides, oxides and hydrides.
- Relate the physical properties of the Period 3 elements to their position in Periodic Table.
- Relate the physical properties of compounds of the Period 3 elements to their nature of bonds across the period.

Introductory activity 14

1. Look at the elements indicated below on the part of the periodic table, what do these elements have in common?

2. Explain how this affects their physical properties such as melting and boiling points, ionization energy, electron affinity, electronegativity and atomic or ionic size.

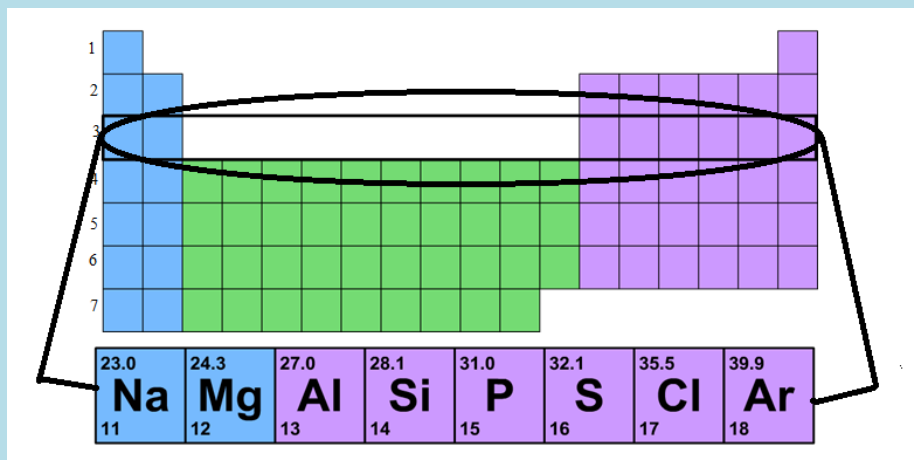

14.1. Physical Properties of the Period 3 elements

Activity 14.1

1. Write the electronic configuration of the following elements in terms of s, p, d and f...:
(i) Sodium (ii) Magnesium (iii) Aluminium (iv) phosphorous (v) sulphur
2. Using the electronic configuration of the elements in 1, explain how it may affect their ionization energies.
3. How do you expect the general trend in ionization energy, electron affinity, melting and boiling point, electronegativity to vary for the elements in the period 3?

4. Considering the electronic configuration of magnesium and Aluminium, phosphorus and sulphur. What can you say about them, how do you expect their ionization energies to vary?

(a) Variation of First ionization energies (IE) of Period 3 elements

First ionization energy generally increases across Period 3. However, it drops between magnesium and aluminium and phosphorus and sulphur before increasing again. (Refer to the data in table 14.1 which is analyzed in the graph for the changes mentioned).

Table 14.1: Variation of first ionization energies of period 3

Element	Proton number	Symbol	1 st ionization energy (kJ/mol)
Sodium	11	Na	496
Magnesium	12	Mg	738
Aluminium	13	Al	578
Silicon	14	Si	789
Phosphorus	15	P	1012
Sulphur	16	S	1000
Chlorine	17	Cl	1251
Argon	18	Ar	1521

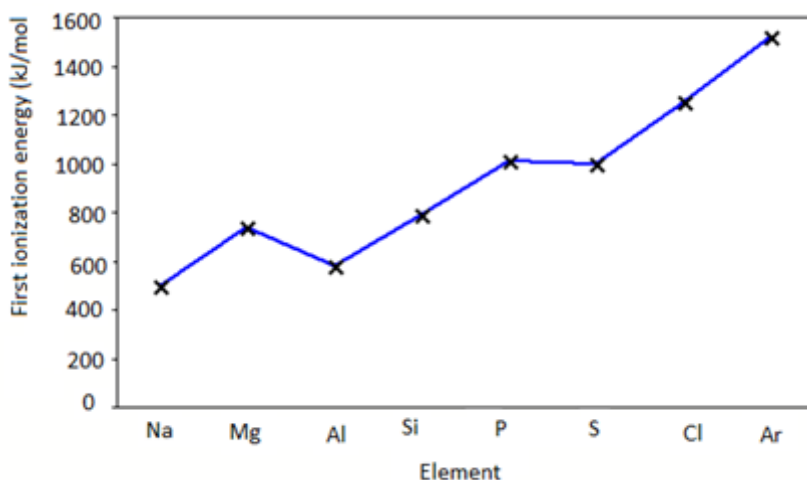

Figure 14.1: Graph of first ionization energies of period 3 elements

Going across Period 3, there are more protons in each nucleus so the nuclear charge in each element increases. Therefore the force of attraction between the nucleus and outer electron is increased, and there is a negligible increase in shielding because each successive electron enters the same energy level. So more energy is needed to remove the outer electron.

Magnesium to aluminium

Magnesium: $1s^2 2s^2 2p^6 3s^2$ and aluminium: $1s^2 2s^2 2p^6 3s^2 3p^1$

The outer electron in aluminium is in a p sub-level. This is higher in energy than the outer electron in magnesium, which is in an s sub-level, so less energy is needed to remove it as shown in the graph (Fig. 14.1)

Phosphorus to sulphur

Phosphorus: $1s^2 2s^2 2p^6 3s^2 3p^3$ and sulphur: $1s^2 2s^2 2p^6 3s^2 3p^4$

Similarly,

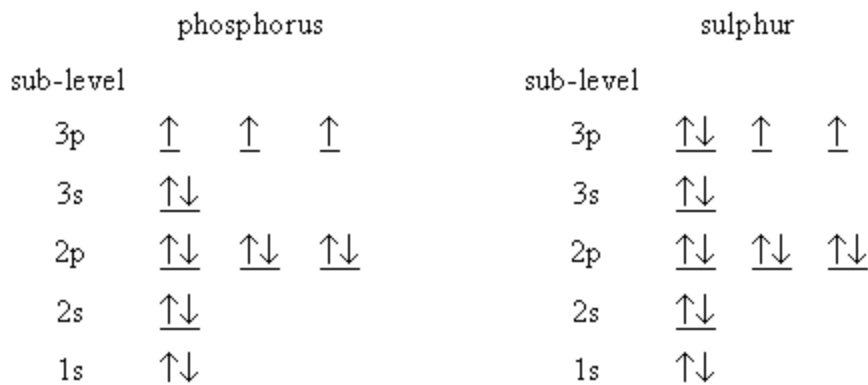

The 3p electrons in phosphorus are all unpaired. In sulphur, two of the 3p electrons are paired as shown above. There is some repulsion between paired electrons in the same sub-level. so less energy is needed to remove one of these paired electrons than is needed to remove an unpaired electron from phosphorus.

(b)Variation of atomic radius of Period 3 elements

Table 14.2: Variation of atomic radius of period 3 elements

Element	Proton number	Symbol	Atomic radius (nm)
Sodium	11	Na	0.191
Magnesium	12	Mg	0.160
Aluminium	13	Al	0.130
Silicon	14	Si	0.118
Phosphorus	15	P	0.110
Sulphur	16	S	0.102
Chlorine	17	Cl	0.099
argon	18	Ar	0.095

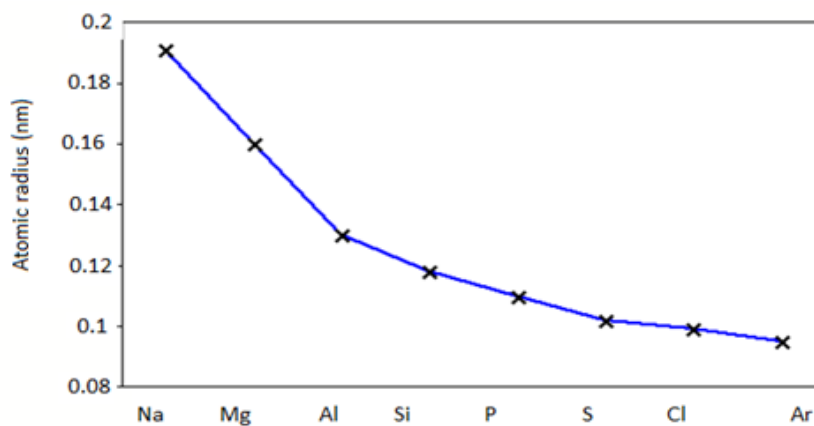

Figure 14.2: Graph showing the variation of atomic radius of period 3 elements

Going across Period 3, the number of protons in the nucleus increases so, the nuclear charge increases. There are more electrons, but the increase in shielding is negligible because each extra electron enters the same principal energy level. Therefore, the force of attraction between the nucleus and the electrons increases. So the atomic radius decreases as indicated in the graph 14.2 and table 14.2.

As the number of electrons in each atom increases going across Period 3 from left to right, you might expect the atomic radius to increase. This does not happen, because the number of protons also increases and there is relatively little extra shielding from electrons in the same principal energy level; the electrons are being filled on the same energy level, they experience more attraction of the nucleus as the number of protons increases.

(c) Variation of electronegativity of Period 3 elements

Table 14.3: Variation of electronegativity of period 3 elements

Element	Proton number	Symbol	Electronegativity (scale 0 to 4)
sodium	11	Na	0.9
magnesium	12	Mg	1.2
aluminium	13	Al	1.5
silicon	14	Si	1.8
phosphorus	15	P	2.1
sulphur	16	S	2.5
chlorine	17	Cl	3.0

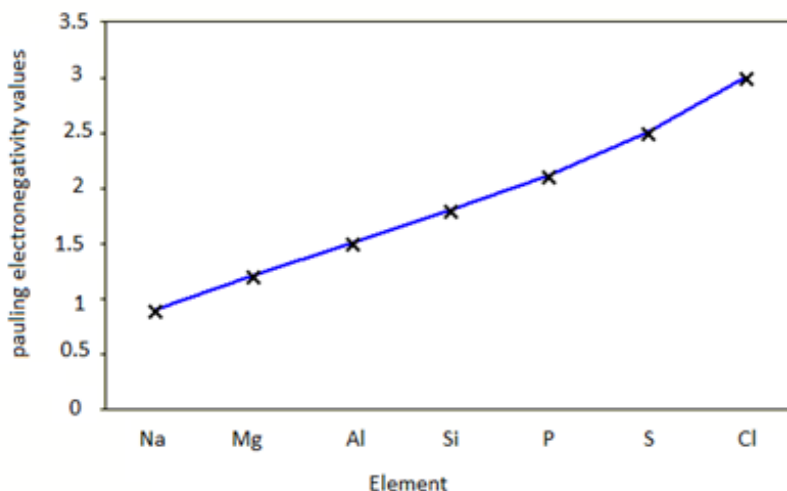

Figure 4.3: Graph showing the variation of electronegativity of period 3 elements

Going across Period 3, electronegativity increases almost linearly due to the nuclear charge increase as atomic radius decreases. There are more electrons, but the increase in shielding is negligible because each extra electron enters the same principal energy level so electrons will be more strongly attracted to the nucleus.

You might expect argon (with 18 electrons) to be the most electronegative element in Period 3, but its outer energy levels are full. Therefore, it does not form covalent bonds with other atoms, so it is given an electronegativity value of zero.

(d) Variation of melting and boiling points in Period 3

Melting and boiling points generally increase going from sodium to silicon, then decrease going to argon (with a “jump” at sulphur). Refer to the graph (not on scale) 14.4 and table 14.4.

Table 14.4: Variation of melting and boiling points of period 3 elements

Element	Proton number	Symbol	Melting point (K)	Boiling point (K)
sodium	11	Na	371	1156
magnesium	12	Mg	922	1380

aluminium	13	Al	933	2740
silicon	14	Si	1683	2628
phosphorus	15	P	317	553
sulphur	16	S	392	718
chlorine	17	Cl	172	238
argon	18	Ar	84	87

Sodium, magnesium and aluminium are all metals. They have metallic bonding, in which positive metal ions are attracted to delocalized electrons. Going from sodium to aluminium: The charge on the metal ions increases from $+1$ to $+3$ (through magnesium at $+2$), the number of delocalized electrons increases, so the strength of the metallic bonding increases and the melting points and boiling points increase.

Silicon has giant covalent bonding. It has a giant lattice structure similar to that of diamond, in which each silicon atom is covalently-bonded to four other silicon atoms in a tetrahedral arrangement. This extends in three dimensions to form a giant molecule or macromolecule and this explains the very high melting point and boiling point.

Phosphorus, sulphur, chlorine and argon, are all non-metals, and they exist as small, separate molecules. Phosphorus, sulphur and chlorine exist as simple molecules. Argon exists as separate atoms (monatomic). When these four substances melt or boil, it is the van der Waals' forces between the molecules which are broken with very weak bonds that need little energy to overcome them. This explains why their melting and boiling points are low. However, Sulphur has a higher melting point and boiling point than the other three because

Phosphorus exists as P_4 molecules, Sulphur exists as S_8 molecules, chlorine exists as Cl_2 molecules, and argon exists as individual Ar atoms.

The strength of the van der Waals' forces decreases as the size of the molecule decreases, so the melting points and boiling points decrease in the order $S_8 > P_4 > Cl_2 > Ar$

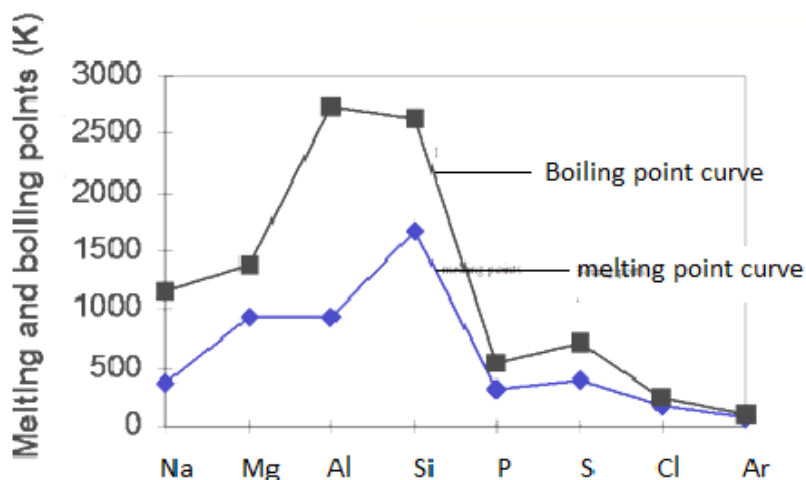

Figure 14.4: The graph showing the variation of melting and boiling points across period 3 elements

(e) Variation of electrical conductivity of Period 3 elements

Electrical conductivity increases going across Period 3 from sodium to aluminium, then decreases sharply to silicon as indicated by the graph 14.5 below.

Table 14.5: Variation of relative electrical conductivity of period 3 elements

Element	Proton number	Symbol	Relative electrical conductivity (Al = 1)
Sodium	11	Na	0.26
Magnesium	12	Mg	0.42
Aluminium	13	Al	1.00
Silicon	14	Si	0.10
Phosphorus	15	P	0
Sulphur	16	S	0
Chlorine	17	Cl	0
Argon	18	Ar	0

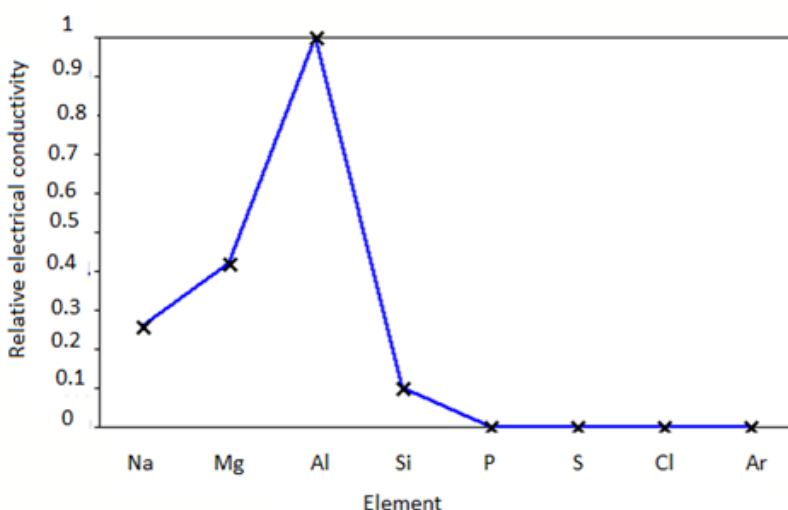

Figure 14.5: Graph showing the variation of relative electrical conductivity of period 3 elements

The delocalized electrons are free to move and carry charge. Going from sodium to aluminium: The number of delocalized electrons increases, there are more electrons which can move and carry charge so the electrical conductivity increases.

Silicon is called a semi-conductor because at higher temperatures more electrons are promoted to the higher energy levels so there are more delocalized electrons to move and carry charge.

Phosphorus, sulphur and chlorine, the outer electrons are not free to move and carry charge because they are held strongly in covalent bonds. In argon (mono atomic) the outer electrons are not free to move and carry charge because they are held strongly in a stable third energy level and this explains their zero electrical conductivity.

(f) Variation of metallic character of period 3 elements

Metallic character decreases as you move across a period 3 in the periodic table from left to right. This occurs as atoms more readily accept electrons to fill a valence shell than lose them to remove the unfilled shell.

Note that as the metallic character reduces across the period, the reducing power decreases as oxidizing power increases.

(g) Variation of electron affinity across period 3 elements

The **electron affinity** [EA] is the energy change for the process of adding an electron to a gaseous atom to form an anion (negative ion).

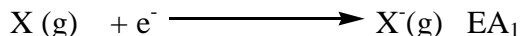

As we might predict, it becomes easier to add an electron across a series of atoms as the effective nuclear charge of the atoms increases. As we go from left to right across a period 3, EAs tend to become more negative, i.e. ability to acquire electrons increases.

The exceptions found among the elements of group 2 (2A), group 15 (5A), and group 18 (8A) can be understood based on the electronic structure of these groups.

Magnesium and phosphorous have anomalous electron affinity, Magnesium has a positive EA while phosphorous is less negative. This is due their electron arrangement, where in magnesium the electron should be added to 2p orbital which is a less stable structure compared to the electronic structure of the atom $[Ne]3s^2$. Similarly in phosphorous the electron should be added to 3p orbital which is half filled and thermodynamically stable.

Element	Na	Mg	Al	Si	P	S	Cl
Electron affinity	-20	+67	-30	-135	-60	-200	-365

Checking up 14.1

1. explain the variation of the following terms as applied in period 3 of the periodic table:

- (i) Ionization energy, Electronegativity,)
- (ii) Explain the anomalous behavior indicated by magnesium and phosphorous in graph 14.1 above

2. The table below shows the melting points of the period 3 elements except for silicon:

Element	Na	Mg	Al	Si	P	S	Cl	Ar
Mp/K	371	923	933	-	317	392	172	84

(a) Explain in terms of bonding why the melting point of magnesium is higher than that of sodium.

(b) Predict the approximate melting point of silicon.

(c) Explain why chlorine has a lower melting point than sulphur.

(d) Predict the approximate melting point of potassium and give one reason why it is different from that of sodium.

(e) Explain the variation of metallic character, electronegativity, first ionization energy, melting and boiling points, electron affinity and electrical conductivity of elements of period 3.

2. (a) Explain the term second ionization energy.

(b) Sketch a graph of the second ionization energy against proton number for the period 3 elements from sodium to argon. explain the shape of the graph

(c) The period 3 elements show a periodic change in other physical properties as well. Explain the variation of the following physical properties:

(i) atomic radii

(ii) melting point

(iii) electrical conductivity

3. the first 6 successive ionization energies of element A is:

1400, 2900, 4600, 7500, 9400, 53300 KJ/mol.

(i) Determine the group number of A. explain your answer

(ii) Write the electronic configuration of A and explain how this electronic configuration obeys

14.2. Chemical properties of period 3 elements

Activity 14.2

(a) Experiment to investigate the action of water on period 3 elements

Materials /apparatus

Water , test tubes, a piece of sodium metal, aluminium powder, magnesium ribbon/powder, red litmus paper/ universal indicator

Procedure:

1. Put about 5cm³ of water in each of the three test tubes arranged in a test tube rack
2. Add a small piece of Mg, Na and Al in each of the three test tubes in 1.
3. Record your observations in a suitable table.

Study questions:

1. What do you say about your observations made in experiment above.
2. Write equation for the reaction that occurs in each test tube in procedure 2.

(b) Experiment to investigate the action of heat on period 3 elements

Materials /apparatus:

Water , test tubes, a piece of sodium metal, aluminium powder/sheet, magnesium ribbon/powder, phosphorous and sulphur powder, universal indicator , pair of tongs, source of heat

Procedure:

1. Hold a piece of magnesium ribbon on a Bunsen flame and record your observation.
2. Repeat experiment 1 for sodium, aluminium, phosphorous and sulphur and record your observation in each case.
3. For each of the products formed i.e. for metal oxides formed, add water and dip a litmus paper to test their nature.

Note: if the oxide is gaseous hold a piece of litmus paper on the mouth of the test tube.

Study questions:

1. Write equations to show how the metals react with oxygen.
2. What would you expect to observe when the metal is burned in oxygen.

a) Reaction with water

Reactivity with water generally decreases across the period because there is a decrease in metallic properties.

i) Sodium reacts vigorously with cold water to form sodium hydroxide and hydrogen gas.



ii) Magnesium does react slowly with cold water to form magnesium hydroxide solution, but with steam the reaction is faster to form magnesium oxide and hydrogen gas.

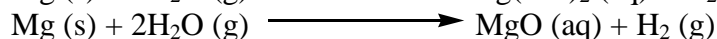
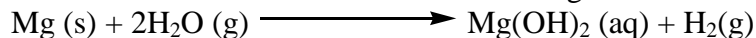

iii) Aluminium reacts with steam very slowly to form aluminium hydroxide and hydrogen gas.

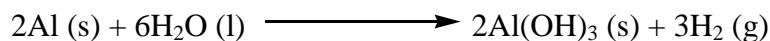

Aluminum powder heated in water vapor produces hydrogen and aluminum oxide. The reaction is relatively slow because of the existing strong aluminum oxide layer on the metal, and the build-up of more oxide during the reaction.

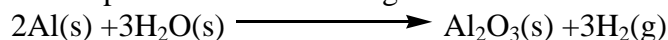

Silicon reacts less slowly with steam at red heat to produce silicon dioxide and hydrogen.

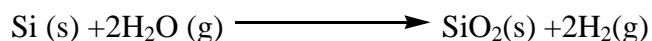

Phosphorus and sulfur have no reaction with water.

Chlorine dissolves in water to give a green solution. A reversible reaction produces a mixture of hydrochloric acid and chloric(I) acid (hypochlorous acid).

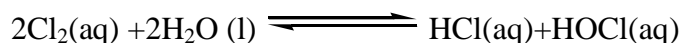

In the presence of sunlight, the chloric(I) acid slowly decomposes to produce more hydrochloric acid, releasing oxygen gas:

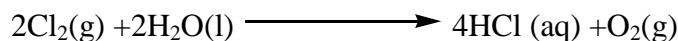

There is no reaction between of argon and water that is known.

(b) Reaction with oxygen

Elements must be heated to react; however,

Dry white phosphorus can ignite spontaneously which is why it is stored under water.

The reactivity depends a lot on the state of subdivision

Sodium: vigorous reaction with ignited sodium, ionic sodium oxide formed.

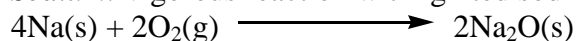

Magnesium: vigorous reaction with ignited magnesium, ionic magnesium oxide formed

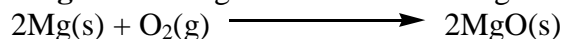

Aluminium: sheets of aluminium get slowly coated with thin oxide layer powdered of aluminium oxide.

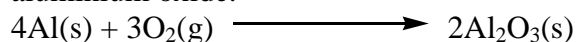

Silicon vigorous reaction with silicon powder, covalent giant molecular silicon dioxide formed

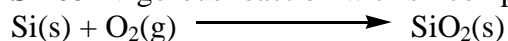

Phosphorus(white) ignites spontaneously in oxygen forming white solid phosphorous (v) Oxide

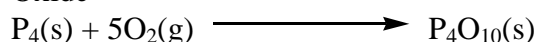

Sulphur burns with a lilac flame to give a choking gas which fumes in moist air, covalent molecules of sulphur dioxide formed.

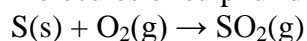

c. Reaction with NaOH

i) Sodium and magnesium have no reaction with sodium hydroxide because they are metals and magnesium falls below sodium in the reactivity series.

ii) Aluminium reacts with aqueous NaOH to produce hydrogen and a complex ion aluminate, Al(OH)_4^-

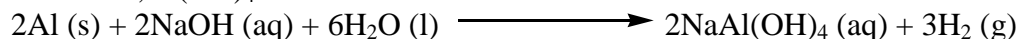

This is because aluminium is Amphoteric, i.e., possesses both metallic and non metallic properties. ie when it reacts with a base it behaves as an acid and similarly when it reacts with an acid it behaves as a base.

ii) Chlorine reacts to form sodium chlorate (I), sodium chloride and water.

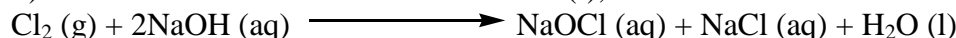

Sodium hypochlorate (I) is used as a bleaching and antiseptic agent such as in Jik

iii) Phosphorus reacts with hot concentrated NaOH to produce phosphine

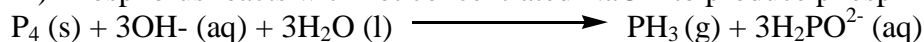

(iv) Si, S have no reaction with sodium hydroxide.

c. Reaction with HCl.

Reactivity decreases across the period due to decrease in metallic properties.

Na, Mg, Al react to form H_2 and metal salts.

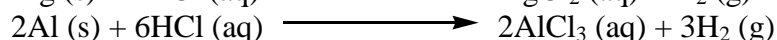
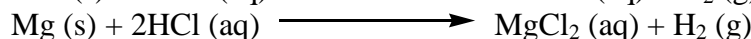
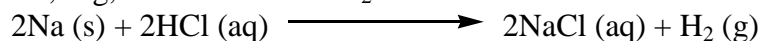

ii) Si, P, S, Cl has no reaction with hydrochloric acid

(d) Reaction with Hydrogen

Sodium and magnesium react with hydrogen to form ionic hydrides

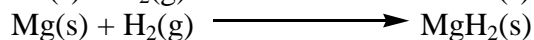
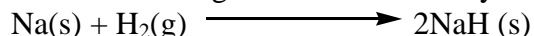

Non metals such as chlorine react with hydrogen to form hydrogen chloride gas

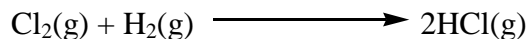

14.3. Compound of period 3 elements

(b) The oxides of period 3 elements:

Activity 14.3(b)

1. Write the formulae of the oxides of period 3 elements
2. What did you consider when writing the formulae of the oxide in 1 above?
3. How do you expect the oxides to behave in water? Explain your answer.
4. Suggest the trend of acid- base character of the oxides of period 3

5. How do you expect the type of structure of the oxides has on the influence of physical properties (use reference of melting and boiling points and physical state)

Sodium	Magnesium	Aluminium	Silicon	phosphorous	Sulphur	Chlorine
Na	Mg	Al	Si	P	S	Cl
Na ₂ O	MgO	Al ₂ O ₃	SiO ₂	P ₄ O ₁₀	SO ₂	Cl ₂ O ₇
				P ₄ O ₆	SO ₃	Cl ₂ O

The metallic oxides on the left of the period adopt giant structures of ions; in the middle, silicon forms a giant covalent oxide (silicon dioxide); the elements on the right form simple molecular oxides with simple structures. The intermolecular forces binding one molecule to its neighbors are van der Waals dispersion forces or dipole-dipole interactions.

Physical properties of the oxides of period 3 elements

Melting and boiling points: the metal oxides and silicon dioxide have high melting and boiling points because a large amount of energy is needed to break the strong bonds (ionic or covalent) operating in three dimensions. The oxides of phosphorus, sulfur and chlorine consist of individual molecules, simple or polymeric.

Electrical conductivity: None of the oxides above have any free or mobile electrons, indicating that none of them will conduct electricity when solid.

Phosphorus has two common oxides, phosphorus(III) oxide, P₄O₆, and phosphorus(V) oxide, P₄O₁₀.

Phosphorus(III) oxide is a white solid, melting at 24°C and boiling at 173°C.

Phosphorus(V) oxide is also a white solid, which sublimates at 300°C. In this case, the phosphorus uses all five of its outer electrons in the bonding.

Sulphur has two common oxides, sulphur dioxide (sulphur(IV) oxide), SO₂, and sulphur trioxide (sulphur(VI) oxide), SO₃.

Sulphur dioxide is a colorless gas at room temperature with an easily recognized pungent smell. It consists of simple SO₂ molecules.

Pure sulphur trioxide is a white solid with a low melting and boiling point. It reacts very rapidly with water vapor in the air to form sulfuric acid. Under laboratory conditions, it forms a white sludge which fumes dramatically in moist air (forming a fog of sulfuric acid droplets).

Chlorine forms several oxides. Two are considered here: chlorine(I) oxide, Cl₂O, and chlorine(VII) oxide, Cl₂O₇.

Chlorine (I) oxide is a yellowish-red gas at room temperature. It consists of simple, small molecules.

In chlorine (VII) oxide, the chlorine involves all of its seven valence electrons in bonds with oxygen. This produces a molecule much larger than chlorine (I) oxide, suggesting higher melting and boiling points. Chlorine (VII) oxide is a colorless oily liquid at room temperature.

Checking up 14.2

1. The table below relates to oxides of period 3 in the periodic table

Oxide	Na ₂ O	MgO	Al ₂ O ₃	SiO ₂	P ₄ O ₁₀	SO ₃
Melting point / ^o C	1275	2827	2017	1607	580	33
Bonding						
Structure						

(a) Copy and complete the table using the following guidelines

(i) Complete the 'bonding' row using only the words *ionic* or *covalent*

(ii) Complete the 'structure' row using *simple molecular* or *giant*

(iii) Explain in terms of forces, the difference between the melting points of MgO and SO₃.

(b) The oxides Na₂O, Al₂O₃, SO₃, were each separately added to water. For each oxide, construct a balanced equation for its reaction with water

14.4 Acid-base Behavior of the Oxides

Activity 14.4

1. Classify the oxides in terms physical states of the oxides of period 3.

2. How do you expect the oxides react with water, acids, and sodium hydroxide. (use equations to justify your answer)

3.(a) Predict the nature of oxides of period 3 elements when dissolved in water.

(b)What would you expect to observe when both blue and red litmus papers are dropped into each of the solutions formed in question (2) above in water.

Acidity increases from left to right, ranging from strongly basic oxides on the left to strongly acidic ones on the right, with an Amphoteric oxide (aluminum oxide) in the middle.

Reaction of oxides with water: Sodium oxide reacts exothermically with cold water to produce sodium hydroxide solution.

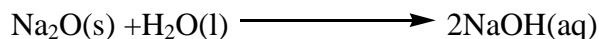

As a strong base, sodium oxide also reacts with acids. It reacts with dilute hydrochloric acid to produce sodium chloride solution.

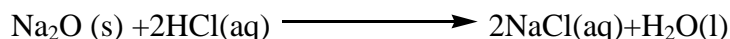

Magnesium oxide powder reacts less slowly with water forming magnesium.

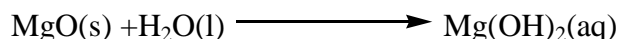

(Mg(OH)₂ is used as anti-acid medicine to treat stomach acidity; it is packed as a white powder and when it is mixed with water, it forms a heterogeneous mixture (suspension) of Mg(OH)₂ and water called “Milk of magnesia or Magnesia milk”.)

Magnesium oxide reacts with acids as predicted for a simple metal oxide. For example, it reacts with warm dilute hydrochloric acid to give magnesium chloride solution.

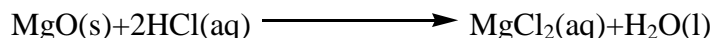

Aluminum oxide is insoluble in water and does not react like sodium oxide and magnesium oxide. The oxide ions are held too strongly in the solid lattice to react with the water.

Aluminum oxide contains oxide ions, and thus reacts with acids in the same way sodium or magnesium oxides do. Aluminum oxide reacts with hot dilute hydrochloric acid to give aluminum chloride solution.



Aluminum oxide also displays acidic properties, as shown in its reactions with bases such as sodium hydroxide. Aluminum oxide reacts with hot, concentrated sodium hydroxide solution to produce a colorless solution of sodium tetrahydroxoaluminate:

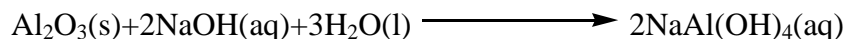

These reactions display the Amphoteric nature of aluminum oxide.

Silicon dioxide does not react with water, due to the difficulty of breaking up its network covalent structure.

Silicon dioxide reacts with hot, concentrated sodium hydroxide solution, forming a colorless solution of sodium silicate:

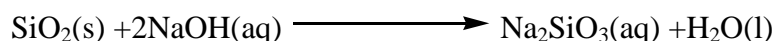

In another example of acidic silicon dioxide reacting with a base, the Blast Furnace extraction of iron, calcium oxide from limestone reacts with silicon dioxide to produce a liquid slag, calcium silicate:



Two phosphorus oxides, phosphorus(III) oxide, P₄O₆, and phosphorus(V) oxide, P₄O₁₀, are considered here.

Phosphorus(III) oxide reacts with cold water to produce a solution of the weak acid, H₃PO₃ known as phosphorous acid, orthophosphorous acid or phosphonic acid:

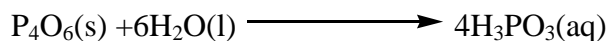

Phosphorus(III) oxide is unlikely to be reacted directly with a base. In phosphorous acid, the two hydrogen atoms in the -OH groups are acidic, but the third hydrogen atom is not. Therefore, there are two possible reactions with a base like sodium hydroxide, depending on the amount of base added:

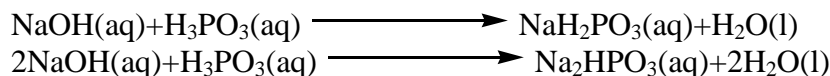

In the first reaction, only one of the protons reacts with the hydroxide ions from the base. In the second case (using twice as much sodium hydroxide), both protons react.

If instead phosphorus(III) oxide is reacted directly with sodium hydroxide solution, the same salts are possible:

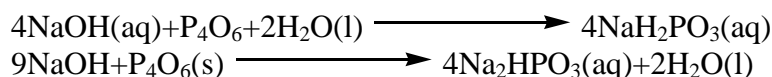

Phosphorus(V) oxide: Phosphorous(V) oxide reacts violently with water to give a solution containing a mixture of acids, the nature of which depends on the reaction conditions. Only one acid is commonly considered, phosphoric(V) acid, H_3PO_4 (also known as phosphoric acid or as orthophosphoric acid).

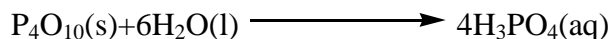

Phosphoric(V) acid is another weak acid, marginally weaker than phosphorous acid.

Phosphoric (V) oxide is also unlikely to be reacted directly with a base, but the hypothetical reactions are considered. In its acid form, molecule has three acidic -OH groups, which can cause a three-stage reaction with sodium hydroxide.

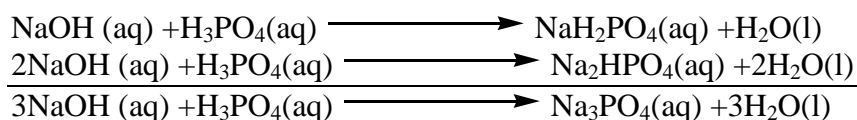

Similar to phosphorus (III) oxide, if phosphorus (V) oxide reacts directly with sodium hydroxide solution, the same possible salt as in the third step (and only this salt) is formed:

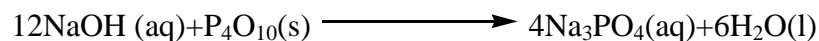

Two oxides are considered: sulfur dioxide, SO_2 , and sulfur trioxide, SO_3 .

Sulphur dioxide is fairly soluble in water, reacting to give a solution of sulphurous acid, H_2SO_3 , as shown in the reaction below.

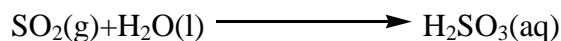

This reaction is the one that takes places in atmosphere and forms acidic rain with diverse effects on the environment.

Sulphur dioxide also reacts directly with bases such as sodium hydroxide solution. Bubbling sulfur dioxide through sodium hydroxide solution first forms sodium sulphite solution, followed by sodium hydrogen sulphite solution if the sulfur dioxide is in excess.

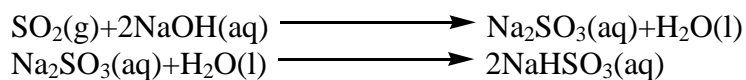

Sulphur trioxide reacts violently with water to produce a fog of concentrated sulphuric acid droplets.

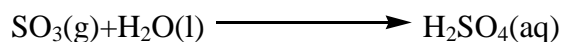

Chlorine forms several oxides, but only two (chlorine(VII) oxide, Cl_2O_7 , and chlorine(I)oxide, Cl_2O) are considered here. Chlorine(VII) oxide is also known as dichlorineheptoxide, and chlorine(I) oxide as dichlorine monoxide.

In Chlorine(VII) oxide, chlorine atom is in its maximum oxidation state of (VII) Chlorine(VII) oxide reacts with water to give the very strong acid, chloric(VII) acid, also known as perchloric acid.

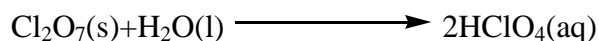

Chloric(VII) acid reacts with sodium hydroxide solution to form a solution of sodium chlorate(VII):

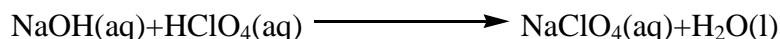

Chlorine(I) oxide is far less acidic than chlorine(VII) oxide. It reacts with water to some extent to give chloric(I) acid, HOCl also known as hypochlorous acid.

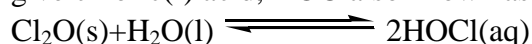

Chloric(I) acid is very weak acid and reacts with sodium hydroxide solution to give a solution of sodium chlorate(I) (sodium hypochlorite):

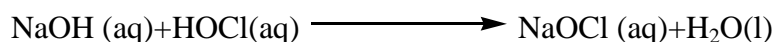

Checking up 14.3

1. Consider the following oxides:

CaO , Al_2O_3 , Na_2O , MgO , P_2O_5 , SO_2 , SiO_2 .

(a) State which of the oxides are:

(i) Basic (ii) acidic (iii) neutral (iv) Amphoteric

(b) Describe briefly how you could test to see whether a solid oxide was basic, acidic, neutral or Amphoteric

2. (a) In each of the following species state whether the metal to non metal bond is ionic or

covalent : Na_2O , Al_2O_3

(b) An inorganic oxide is a white solid of melting temperature 1710°C and is unreactive towards water.

(i) State and explain whether or not this is sufficient information to deduce whether the bonding is ionic or covalent.

(ii) Outline one additional test which could be applied to substantiate your conclusion.

(b) The Chlorides of Period 3 Elements

Activity 14.3(b)

The table below gives some data about the chlorides of elements of period 3

Formula	NaCl	MgCl ₂	AlCl ₃	SiCl ₄	PCl ₃	S ₂ Cl ₂	Cl ₂
Boiling point/ ^o C	1465	1418	423	57	76	136	-34
pH of aqueous solution	7	6	2	2	2	1	1

(a) Explain why the boiling point of NaCl is higher than that of MgCl₂.

(b) Explain why the pH of NaCl is 7 and that of AlCl₃ is 2.

The chlorides of interest are given in the table below:

Sodium	Magnesium	Aluminium	Silicon	Phosphorous	Sulphur
NaCl	MgCl ₂	AlCl ₃	SiCl ₄	PCl ₅	S ₂ Cl ₂
				PCl ₃	

Sulphur forms three chlorides, but S₂Cl₂ is most common. Aluminum chloride also exists under some conditions as a dimer, Al₂Cl₆. Similarly phosphorous forms two chlorides as in the table above.

The structures: Sodium chloride and magnesium chloride are ionic and consist of giant ionic lattices at room temperature. Aluminum chloride exhibits covalency characters. Aluminium ion has high charge density; due to this, the electron cloud of the chloride is distorted. (Easily polarizable).

The combination of the 2 factors above leads to some degree of electron sharing between the positive aluminium ion and the negative chloride ion and hence the covalent character.

The other chlorides are simple covalent molecules.

Melting and boiling points: Sodium and magnesium chlorides are solids with high melting and boiling points because of the large amount of heat which is needed to break the strong ionic attractions.

The rest are liquids or low melting point solids. Leaving aside the aluminum chloride and phosphorus(V) chloride which are either solids or gas, the attractions in others will be much weaker intermolecular forces such as van der Waals or dispersion forces which vary depending on the size and shape of the molecule, but will always be far weaker than ionic bonds.

Electrical conductivity: generally in all chlorides do not conduct in solid state because the solid does not conduct electricity because the ions aren't free to move

Sodium and magnesium chlorides are ionic and so will conduct electricity when they are molten. The rest of the chlorides do not conduct either in solution or molten state due to absence of ions.

Reactions with water

The chlorides of more electropositive metals (NaCl and MgCl₂) dissolve in water to form neutral solution. The other chlorides (covalent) hydrolyze or react with water to form acidic solutions. As shown below:

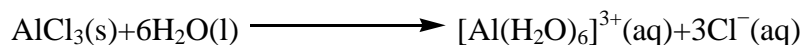
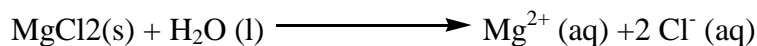
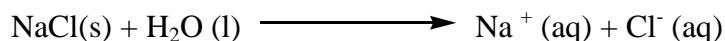

The greater charge attracts electrons in the water molecules quite strongly toward the aluminum, making the hydrogen atoms more positive and therefore easier to remove from the ion.

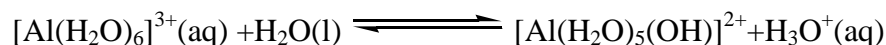

or, more simply:

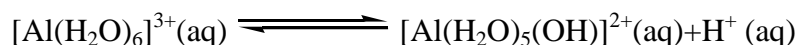

Silicon (iv) chloride fumes in moist air because it reacts with water in the air to produce hydrogen chloride. If you add water to silicon tetrachloride, there is a violent reaction to produce silicon dioxide and fumes of hydrogen chloride.



Phosphorus(III) chloride and Phosphorus(V) chloride reacts violently with water to generate phosphorous acid, H₃PO₃, phosphoric acid, H₃PO₄ and hydrogen chloride fumes respectively.

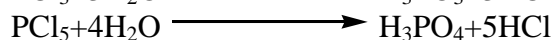

Disulphur dichloride reacts slowly with water to produce a complex mixture of hydrochloric acid, sulfur, hydrogen sulfide and various sulfur-containing acids and anions.

Checking up 14.4

- (a) Distinguish between dissolving and hydrolysis.
(b) Name one chloride that dissolves in water, and one chloride that undergo hydrolysis.
(c) state how the bonding in the chlorides changes on crossing the second and third periods.
(d) Suggest two ways how you would know that a reaction has taken place when a few drops of water is added to silicon (iv) chloride.
- (a) write an equation that shows why a solution of beryllium chloride in water is acidic.
(b) Predict the shape of PCl_3 molecule and suggest a likely bond angle.
(c) Iron (iii) chloride, FeCl_3 , forms dimers in the gas phase similar to those of aluminium chloride. Draw the likely structure of these two dimers.
- Carbon and silicon are the same group of the periodic table and forms chloride of CCl_4 and SiCl_4 respectively. However, CCl_4 does not undergo hydrolysis whereas SiCl_4 hydrolyses in water to form white fumes of the gas.
(a) identify the white fumes
(b) Write equation for the reaction to show how silicon (iv) chloride hydrolyses in water.
(c) Explain why silicon (iv) chloride hydrolyses whereas carbon tetrachloride does not.

(c) The hydrides of period 3 elements

Activity 14.4(c)

- Period 3 elements from sodium to chlorine form different hydrides of different bond nature, physical properties and structure.
(a) Write the formula of the hydrides formed by period 3 elements.
(b) Predict the nature of bonding based on your knowledge of periodicity of elements in the periodic table.
(c) Basing on the nature of bonding predicted in (b) above. How would you expect their boiling and melting point vary across the period?
(d) Predict the nature of solutions formed by hydrides when dissolved in water. What would you expect to observe if red and blue litmus papers were separately dropped into each solution?

Hydrides are commonly named after binary compounds that hydrogen forms with other elements of the periodic table. Hydride compounds in general form with almost any element, except a few noble gases. The common hydrides of period 3 elements are as shown in the table 14.5 below

Element	Na	Mg	Al	Si	P	S	Cl
Formula of hydride	NaH	MgH_2	AlH_3	SiH_4	PH_3	H_2S	HCl
Nature of bonding and structure	Ionic	Partially Ionic	Partially ionic	Covalent small covalent gaseous molecule	Covalent small covalent gaseous molecule	Covalent small covalent gaseous molecule	Covalent small covalent gaseous molecule

The hydrides above are examples of period 3 elements with some of their properties summarized in the table above. As we can see the hydrides of period 3 vary from ionic hydride such as NaH at the left side to polar covalent hydride such as HCl at the right side of the period.

Reactions of hydrides with water

The first three hydrides (NaH, MgH₂ and AlH₃) react with water forming alkaline solutions and hydrogen gas.

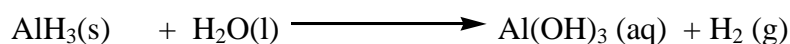
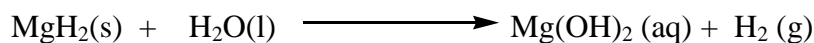
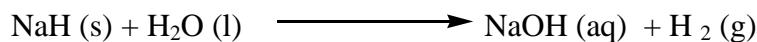

The reactions indicate that as you move across the period, hydroxide ions (OH⁻) are being removed from solutions and becomes less basic. Hence from NaH to AlH₃ via MgH₂ the solutions decrease in alkalinity but increases in acidity. This is caused by Hydrolysis of other hydrides with water.

The rest of the hydrides except PH₃ dissolve to give acidic solutions.

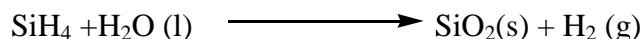
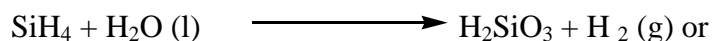

PH₃ is non polar because P and H have almost equal electronegativity and hence does not react with water.

Hydrogen sulphide dissolves in water partially while hydrogen chloride dissolves completely form strong acidic solutions respectively

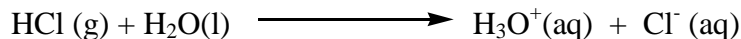
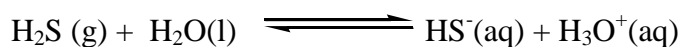

Therefore the nature of hydrides changes from basic to acidic across the period 3.

Checking up 14.5

1. The table below gives some properties of oxides of period 3 in the periodic table.

Oxide	Na ₂ O	MgO	Al ₂ O ₃	SiO ₂	P ₄ O ₁₀	SO ₃
Melting point (°C)	1275	2827	2017	1607	580	33

(a) Explain the trend in the melting points of the above oxides and their origin.

(b) Write the equations to show the reaction of

(i) SO₃ with water

(ii) Na_2O

(c) One of the above oxides has acidic and basic character.

(i) Identify that oxide from the above table

(ii) Using equations explain the acidic and basic character of the oxide identify in (c) (i).

2. This question concerns the following oxides: Na_2O , MgO , SiO_2 , and SO_3 .

From the list above identify the oxide that best fits the description given:

(i) An oxide that is insoluble in water.

(ii) An oxide that has simple molecular structure at room temperature and pressure.

(iii) An oxide that reacts with water forming a strongly alkaline solution.

(iv) An oxide that is slightly soluble in water forming weak alkaline solution.

3. There is a link between the properties of the oxides of the Period 3 elements and their structure and bonding. The table below shows the melting points of the oxides of some Period 3 elements.

Oxide	Na_2O	SiO_2	P_4O_{10}
Melting point/K	1548	1883	573

(a) In terms of crystal structure and bonding, explain in each case why the melting points of sodium oxide and silicon dioxide are high.

(b) Predict whether the melting point of lithium oxide is higher than, the same as, or lower than the melting point of sodium oxide and explain your prediction.

(c) Phosphorus (V) oxide has a lower melting point than sodium oxide.

(i) State the structure of and bonding in phosphorus (V) oxide.

(ii) Explain why the melting point of phosphorus(V) oxide is low.

(d) Samples of phosphorus(V) oxide and sodium oxide were reacted with water. In each case, predict the pH of the solution formed and write an equation for the reaction.

4. Sodium chloride is a high melting point solid which dissolves in water to make a colorless solution. Silicon (IV) chloride is a liquid at room temperature which fumes in moist air, and reacts violently with water.

a) Draw a diagram to show the arrangement of the particles in solid sodium chloride, making clear exactly what particles you are talking about.

b) Explain why this arrangement leads to a high melting point.

c) Draw a simple diagram to show the structure of silicon (IV) chloride, and explain why silicon (IV) chloride is a liquid at room temperature.

d) Why is there such a big difference between the chlorides of sodium and silicon?

e) Briefly describe and explain the difference in electrical conductivity between sodium chloride and silicon (IV) chloride in both solid and aqueous molten state.

f) Write an equation to show what happens when silicon (IV) chloride reacts with water.

g) Name another Period 3 chloride which behaves similarly to sodium chloride, and one which behaves similarly to silicon (IV) chloride.

5. With the help of equation describe how the hydrides of period 3 react with water.

14.5. End unit assessment

1. Use the information in the following table to explain the statements below

Element	Na	Mg	Al	Si	P	S	Cl
Atomic radius/nm	0.156	0.136	0.125	0.117	0.110	0.104	0.099
Ionic radius/nm	0.099	0.065	0.050			0.184	0.181
1 st Ionization energy/kJmol ⁻¹	+492	+745	+579	+791	+1060	+1003	+1254

- (a) What is the trend in atomic radius? Explain the origin of that trend.
 (b) The ionic radii of Na⁺, Mg²⁺ and Al³⁺ are less than their respective atomic radii, whereas the ionic radii of Cl⁻ and S²⁻ are greater than their respective atomic radii. Compare the atomic radii with the ionic radii and explain what your observation
 (c) What trend do you observe in the 1st ionization energy? Explain the origin of that trend?
 (d) The first ionization energy of Al is less than that for Mg; why?
2. The table below shows the melting points of the period 3 elements except for silicon.

Element	Na	Mg	Al	Si	P	S	Cl	Ar
Melting point/K	371	923	933		317	392	172	84

- (a) Explain in terms of bonding why the melting point of magnesium is higher than that of sodium
 (b) State the type of bonding between atoms in the element silicon and name the type of structure which silicon forms.
 (c) Predict the approximate melting point of silicon.
 (d) Explain why chlorine has a lower melting point than sulphur.
 (e) Predict the approximate melting point of potassium and give one reason why it is different from that of sodium.
3. The elements Sodium, Magnesium, silicon, phosphorous and chlorine are members of the third period of the periodic table
- (a)(i) Write down the formula of the principal oxides and chlorides of the elements listed above and in each case indicate the type of bonding.
 (ii) Explain what happens when each of the above oxides and chloride is added to water and indicate whether the resultant solution will be acidic, basic or neutral.
 (b)(i) Which of the oxides listed above form oxide of the type X₂O₃
 (ii) Describe briefly how you would prepare each of the oxide and give the equations for the reactions involved.
 (iii) What would be observed if each of the above oxide in (b) (ii) was reacted with sodium hydroxide? Write equation for the reactions involved in each case.
 (c) The melting points of Mg, Si and S are 650^oC, 1423^oC respectively. Explain the differences in the melting points of the elements.
 (d) Name the type bonding that exists in the hydrides of the elements Sodium, Phosphorous and sulphur and write the equations to show the reactions if any of the hydrides with water.
4. Choose from the elements: Sodium, magnesium aluminium, silicon, phosphorous, chlorine and

argon

(a) List the elements that react readily with cold water to form alkaline solutions. And write the equations for the reactions.

(b) List the hydrides that have hydrides with low boiling points/temperatures and explain why.

(c) List the elements that form nitrates and write the formulae of nitrates.

(d) What is the most ionic compound that can be formed by the combination of two of these elements.

(e) Which element has both metallic and non metallic properties?

(f) Name the elements that normally exist as molecules.

5.(a) Describe the formation of Al_2Cl_6 dimers from AlCl_3 monomers in terms of orbital hybridization.

(b) Predict and draw the shapes of BCl_3 , CCl_4 , PCl_3 and SCl_2 , molecules.

(c) Predict draw the shapes of $[\text{PCl}_4]^+$ and $[\text{PCl}_6]^-$ ions, plus the shape of the PCl_5 molecule.

What do you know about nitrogen that would enable you to predict that it is unlikely to form NCl_5 . Explain your reasoning?

UNIT15: FACTORS THAT AFFECT CHEMICAL EQUILIBRIUM

Key unit competency: Deduce how concentration, pressure, catalyst and temperature affect the chemical processes in industry.

Learning Objectives

By the end of this unit, I will be able to:

- Distinguish between complete and reversible reactions.
- Explain dynamic equilibrium.
- State the characteristics of dynamic equilibrium.
- Explain the factors that affect the position of the equilibrium in a reversible reaction.
- Apply Le Châtelier's principle to explain the effects of changes in the temperature, concentration and pressure on a system in equilibrium.
- Compare and contrast theoretical and actual optimal conditions in the industrial processes.
- Relate the effect of concentration, temperature, pressure and catalyst to the amount of products in the manufacturing industries.
- Recognize the importance of Le Châtelier's principle in Haber and Contact processes.

Introductory activity

1. Biological processes in our body need oxygen for proper functioning.

(a) Explain briefly the mechanism of oxygen transport in our bodies in relation to the below diagram.

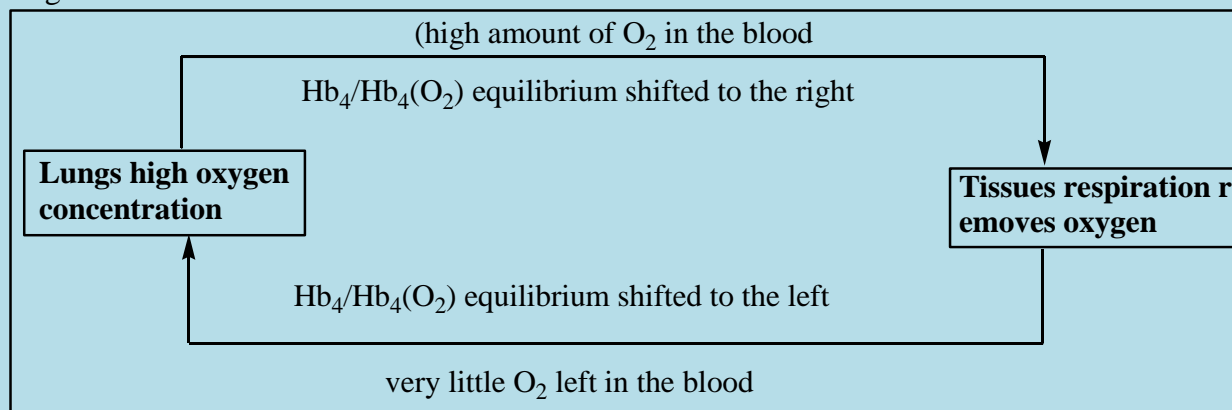

(b) Explain the term homeostasis.

(c) Use an example to explain how homeostasis is important in our bodies.

(d) Suggest other areas in daily life where equilibrium can be applied.

In chemistry, a chemical reaction is a process where old bonds are broken and new bonds are formed. For a chemical reaction to take place, two or more substances called reactants are interacted. In general, when reactants collide with sufficient energy and in a proper orientation, the products are formed. Many chemical reactions proceed to a certain extent and stop. In some cases, reactants combine to form products and the products also start combining to give back the reactants. When such opposing processes take place at equal rates, no reaction appears and it is said that a state of equilibrium has reached. Chemical equilibria are important in numerous

biological and environmental processes. For example, equilibria involving oxygen (O_2) molecules and the protein hemoglobin play a crucial role in the transport and delivery of oxygen from our lungs to cells throughout our body.

The equilibrium reaction for the transport of oxygen by Haemoglobin (Hb) is represented as:

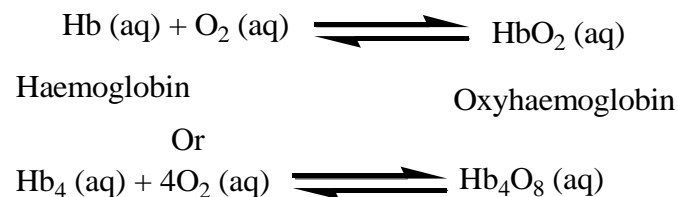

According to Le Châtelier's principle, in the lungs where there is high concentration of oxygen, the equilibrium position shifts to the right resulting in the formation of oxyhaemoglobin. However, the concentration of oxygen is lower in tissues and the equilibrium position shifts to the left. Oxyhaemoglobin releases oxygen to reform haemoglobin.

Other examples of equilibrium reactions in biological processes include: homeostasis (keeping the internal environment conditions constant), carbon monoxide poisoning, buffering action in blood. In daily life activities, it is applied in a tug-of-war game (Figure 15.1), seesaw game (Figure 15.2), and in treadmill found in gymnastic rooms as shown (Figure 15.3).

This unit deals with the characteristics and factors affecting the chemical equilibria.



Figure 15.1 Students pulling a rope in a tug of war game

The above figure shows that when two teams pull on a rope with equal force. The resulting force is equal in magnitude and equal to zero and the rope does not move, the system is said to be in equilibrium.



Figure 15.2: Students on in figure (a) represents a system in equilibrium. The equal and opposite forces on both ends of the seesaw are balancing. If, instead one force is greater in magnitude than the other, the combined force is greater than zero and is not in equilibrium as in figure (b)



Figure 15.3: A runner gradually increases the speed of the treadmill with each change; he/she must increase his/her running speed in order to restore his/her equilibrium at the new treadmill setting. Similarly, a chemist can change the conditions of a reaction at equilibrium in order to increase the amount of product.

15.1. Difference between complete and incomplete reactions (reversible versus irreversible reactions)

Activity 15.1

1. Write any two equations of your choice to show a reaction that undergo completion.
2. Write any two equations of your choice to show a reaction that does not go completion
3. Compare the reactions written above in 1 and 2.

Chemical reaction can proceed in either *non-reversible (irreversible or complete)* or *reversible* reaction.

During chemical processes, many chemical reactions do not undergo completion but instead they attain a state of chemical equilibrium. Chemical reaction can proceed in either *non-reversible (irreversible or complete)* or *reversible* reaction.

Non-reversible reaction is a reaction which proceeds in only *one direction*.

Examples

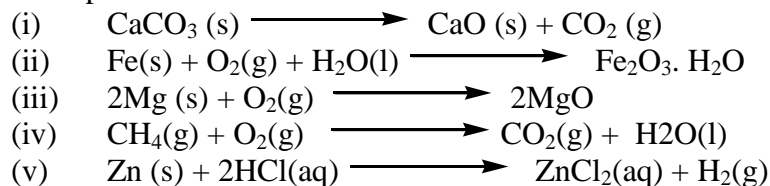

In reversible reactions, both the forward and reverse reactions occur at the same rate. Reversible reactions are indicated by placing two half arrows pointing in opposite directions between the reactants and products. Within these reactions, the reactants form products and products form reactants at the same rate, the reactions are said to be in the equilibrium.

Note that all reactions can be forced to go in either direction depending on particular factors subjected to them.

Examples of reversible reactions

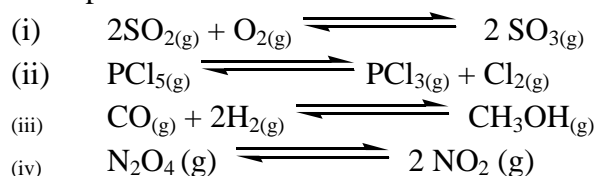

Note: The forward reaction proceeds from left to right.

The reverse reaction proceeds from right to left. The sign \rightleftharpoons or \longleftrightarrow is used to indicate a reversible reaction.

Checking up 15.1

1. Identify the reactions which are non-reversible and reversible by writing the words irreversible and reversible.

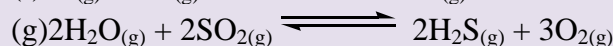
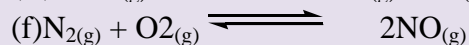
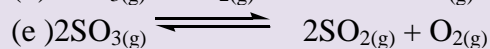
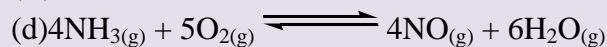

15.2. Concept of equilibrium (dynamic equilibrium) and their Characteristics

Activity 15.2

1. Explain the terms used in equilibrium reactions.
(a) Reversible reaction (b) equilibrium state (c) dynamic equilibrium (d) position of equilibrium.
2. Suggest and explain the characteristics of dynamic equilibrium and how it can be attained.
3. Learners should do a tug-of-war game outside the classroom and comment on the game.

15.2.1. Concept of equilibrium reactions

When a chemical reaction takes place in a container which prevents the entry or escape of any of the substances involved in the reaction, the quantities of these components change as some are consumed and others are formed. The system is then said to be in its *equilibrium state*, or more simply, "*atequilibrium*".

Chemical equilibrium is *the state at which the rate of forward reaction becomes equal to the rate of backward reaction*.

At the initial state, the rate of forward reaction is greater than the rate of backward reaction. However as the products are formed, the concentration of reactants decreases and the concentration of products increases.

For example in a reaction $A + B \longrightarrow C$ or $C \longrightarrow A + B$.

The state of chemical equilibrium can be shown graphically as follows in Figures 15.4(a) and 14.(b)

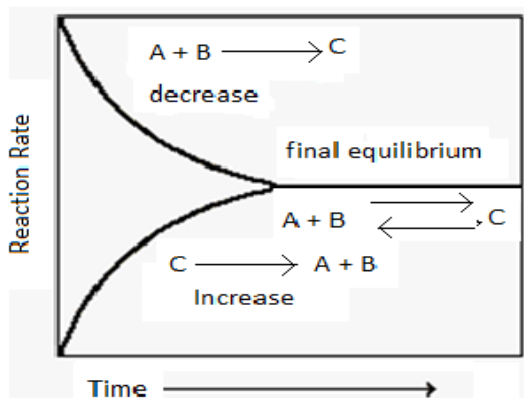

15.4(a) Plot of reaction rate versus time at equilibrium

At the equilibrium, the rate of products is equal to that of reactants.

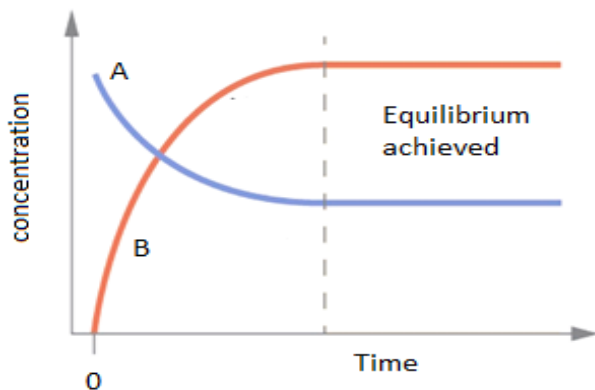

15.4(b) variation of concentration of A and B with time for reversible reaction

Consider the reaction $A \rightleftharpoons B$; the figure 15.4 (b) indicates how the concentration of A decreases while that of B increases for the reaction. The dotted vertical line indicates the time when the concentrations of A and B are equal at equilibrium.

If the reversible reaction is carried out in a closed system, the reaction is said to be in the equilibrium state when the forward and backward reaction occur simultaneously at the same rate and the concentrations of reactants and products do not change with time (Figure 15.4 b).

At this point, the rates of forward and reverse reactions are the same and the system is said to have reached a state of *dynamic equilibrium*.

A dynamic equilibrium is a process where the forward and reverse reactions proceed at the same rate and after a period of time, the concentrations of reactants and products remain constant (do not change). However, in dynamic equilibrium, even if the concentrations of reactants and products do not change, it does not mean that the reaction has stopped. Rather, the reaction is proceeding in a way that it keeps the concentrations unchanged (the net change is zero).

There are two types of chemical equilibrium: homogeneous and heterogeneous equilibria.

In a homogeneous equilibrium, all the reactants and the products are in the same phase. The equilibrium reactions are divided into two categories:

- (i) The number of **product molecules is equal to the number of reactant molecules**. For example:

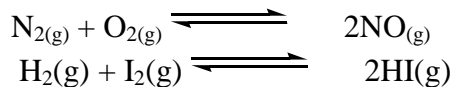

- (ii) The number of **product molecules is not equal to the number of reactant molecules**.

Examples

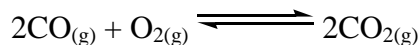

In these examples (1), one reactant molecule is decomposed into two products while in the reaction (2), three reactant molecules give two products.

Other examples of homogeneous equilibrium:



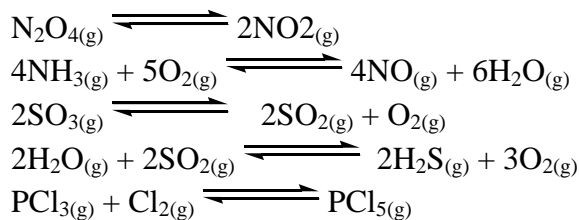

In heterogeneous equilibrium, the reactants and the products are present in different phases. This is the case of an aqueous solution in which the ions combine to produce a slightly soluble solid that forms a precipitate.

Examples:

The dissociation of solid calcium carbonate to give solid calcium oxide and gaseous carbon dioxide:

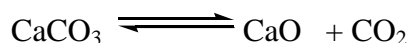

Here CaO and CaCO₃ are pure solids, [CaO] and [CaCO₃] are constants and CO₂ is a gas. The concentrations of pure solids & pure liquids assumed to be constant and these do not appear in equilibrium concentration expression. By convention [solid] = 1 and [liquid] = 1. Other examples of heterogeneous equilibrium reactions are the following:

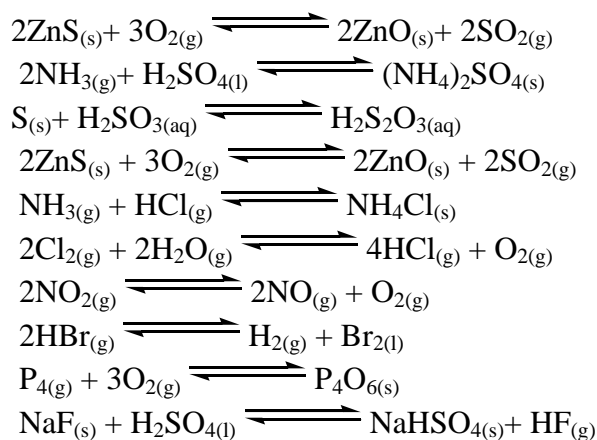

15.1.2. Characteristics of a system in a dynamic equilibrium

A chemical equilibrium is a process where reactants are converted into products and products can react to give back the reactants. The characteristics of a system in dynamic equilibrium are the following;

1. The rate of the forward reaction is equal to the rate of the reverse reaction,
2. Microscopic processes (the forward and reverse reactions) continue in a balance which yields no macroscopic changes (nothing appears to be happening),
3. The system is closed and the temperature is constant and uniform throughout the process,
4. The equilibrium can be approached from the left (starting with reactants) or from the right (starting with products).

Checking up 15.2

1. Briefly explain the characteristics of reactions at equilibrium
2. Compare the homogeneous and heterogeneous reactions using specific examples.
3. By giving an example, describe the term dynamic equilibrium.
4. When does a reaction attain equilibrium state?
5. Using a graph and specific examples, explain what happens during a reaction before, at and after the equilibrium has been attained.

15.3. Factors that affect the reactions in equilibrium and Le Châtelier's principle

Activity 15.3(a)

1. Around 1908-1909 a young German research chemist, Fritz Haber, had discovered that nitrogen and hydrogen would form an equilibrium mixture containing ammonia.
 - (a) Write a balanced equation for the formation of ammonia.
 - (b) Haber's experiment yielded an equilibrium mixture containing only 8% by volume of ammonia. What conditions of temperature and pressure does Le Châtelier's principle predict for maximum yield of ammonia at equilibrium?
 - (c) Why do you think Haber employed the catalyst accompanied with promoters and heat exchanger in his equipment?
2. How is Le Châtelier's principle used to explain the conditions that affect the equilibrium reactions?

Many industrial processes involve reversible reactions. It is important to understand how the variation of conditions can affect the composition of a chemical equilibrium. Some reactions to take place involve some conditions. For example, the rate of a chemical reaction depends on factors that affect the reaction to occur.

It is known that many reactions are reversible and all reversible reactions reach a **dynamic equilibrium** state.

Different factors which can affect the chemical equilibrium include:

1. Temperature
2. Pressure
3. Concentration of reactants and products
4. Catalysts

The effect of the above-mentioned factors on chemical equilibrium can be explained with the use of Le Châtelier's Principle

Le Châtelier's Principle

According to Le Châtelier's Principle, when the temperature, pressure or concentration of a reaction in equilibrium is changed, the reaction shifts in the direction where the effect of these changes is reduced.

15.3.1. Effect of Temperature on equilibrium

Activity 15.4(b)

1. Explain the following terms
(a) endothermic (b) exothermic
(c) Suggest how temperature affects the position of equilibrium.

When dealing with temperature, we distinguish exothermic and endothermic reactions. A change in the temperature of a system already in equilibrium could either *shift the equilibrium to the right* (favoring the forward reaction) or *to the left* (favoring the backward reaction). This depends on whether the forward reaction is exothermic or endothermic. Heat can be considered a reactant in an endothermic reaction and a product in an exothermic reaction. For a reversible reaction, when the forward reaction is exothermic, the enthalpy change is negative ($\Delta H < 0$), then if the backward reaction is endothermic the enthalpy change is positive ($\Delta H > 0$).

Note: For *exothermic forward reactions*, an increase in temperature favors backward reaction, while a decrease in temperature favors the forward reaction.

For *endothermic forward reaction*, an increase in temperature favors forward reaction, while a decrease in temperature favors backward reaction.

Example:

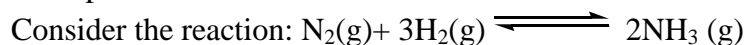

If the forward reaction is exothermic:

According to Le Châtelier's principle, when the temperature is raised, the equilibrium composition of an exothermic reaction will tend to shift towards the reactants which mean that the ammonia will decompose into nitrogen and hydrogen.

If the forward reaction is endothermic:

According to Le Châtelier's principle, when the temperature is raised the equilibrium composition of an endothermic reaction will tend to shift toward the products meaning that the nitrogen and hydrogen will combine together to form ammonia.

In summary:

Increase in temperature $\xrightarrow{\text{shifts the equilibrium in the direction of}}$ Endothermic reaction

Decrease in temperature $\xrightarrow{\text{shifts the equilibrium in the direction of}}$ Exothermic reaction

Effect of temperature on Haber process

The Haber process combines nitrogen from the air with hydrogen derived mainly from natural gas (methane) into ammonia. The reaction is reversible and the production of ammonia is exothermic.

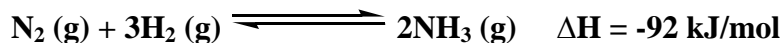

The reaction of the production of ammonia is *exothermic*. According to Le Châtelier's Principle, this exothermic reaction is favored by low temperature and high pressure. The rate of any reaction increases with the temperature, working with temperature alone will cause the reaction to occur very slowly and hence, not efficient. If temperature is increased, the equilibrium will shift to the left to oppose this and move in the endothermic direction in order to reduce the temperature by absorbing heat. For this reaction a low temperature will yield a high amount of ammonia.

Therefore, **400 - 450°C** is a compromise temperature to yield a high proportion of ammonia in the equilibrium mixture (even if it is only 15%), but in a very short time.

In the above example, the endothermic reaction is the backward one; hence the position of equilibrium will shift towards the left, producing a lower quantity of ammonia.

Note: The rate of reaction and percentage yield must be high enough to give a sufficient daily yield of product.

Checking up 15.3.1

Determine whether the following reactions are favored by high or low temperature?

1. $2\text{SO}_2(\text{g}) + \text{O}_2(\text{g}) \rightleftharpoons 2\text{SO}_3(\text{g}); \quad \Delta H^\circ = -180 \text{ kJ}$
2. $\text{CO}(\text{g}) + \text{H}_2\text{O}(\text{g}) \rightleftharpoons \text{CO}_2(\text{g}) + \text{H}_2(\text{g}); \quad \Delta H^\circ = -46 \text{ kJ}$
3. $\text{CO}(\text{g}) + \text{Cl}_2(\text{g}) \rightleftharpoons \text{COCl}_2(\text{g}); \quad \Delta H^\circ = -108 \text{ kJ}$
4. $\text{N}_2\text{O}_4(\text{g}) \rightleftharpoons 2\text{NO}_2(\text{g}); \quad \Delta H^\circ = +57 \text{ kJ}$
5. $\text{CO}(\text{g}) + 2\text{H}_2(\text{g}) \rightleftharpoons \text{CH}_3\text{OH}(\text{g}); \quad \Delta H^\circ = -270 \text{ kJ}$

15.3.2. The effect of change in concentration on equilibrium

Activity 15.4: Experiment to investigate the effect of changing concentration of equilibrium

Equipment/materials

100 ml beaker , Glass stir rods , hot plate , 250 ml beaker for waste collection , distillation water squirt bottle , enough test tubes, 3 ml 0.010 M $\text{Fe}(\text{NO}_3)_3$, 1 ml 0.10 M $\text{Fe}(\text{NO}_3)_3$, 1 ml 0.05 M NaSCN , 0.1 ml 0.10 M AgNO_3 , ~0.1 ml 1.0 M NaNO_3 , 15 ml 0.10 M $\text{Co}(\text{NO}_3)_2$ (plus some in a dropper bottle) , 10 ml 12 M HCl

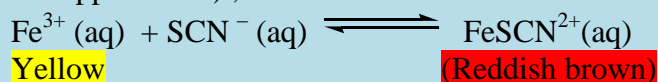

Part A:

Procedure

In five test tubes , place 2 drops of 0.05 M NaSCN (sodium thiocyanate), 2 drops of 0.01 M Fe(NO₃)₃ solution, and 3 drops of deionized water. Make sure you have taken the correct concentrations of each solution. Mix each with a stirring rod; all of the solutions should appear **red/brown**

Procedure: Add 2 drops of deionized water to test tube 1. This well will serve as your color comparison for the following experiments.

Add 2 drops of 0.10 M Fe(NO₃)₃ to test tube 2. Record your observations in table.

Add 2 drops of 0.05 M NaSCN to test tube 3. Record your observations in table.

Add 1 drop of 0.10 M AgNO₃ to test tube 4. Record your observations in table.

Add 1 drops of 1.0 M NaNO₃ to test tube 5. Record your observations in table.

Table A: Observations for the Equilibrium:

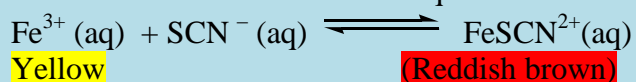

Test tube #	Stress applied	observations made
1	None , control for comparison	
2	Add 0.10M Fe(NO ₃) ₃	
3	Add 0.05 M NaSCN	
4	Add 0.10 M AgNO ₃	
5	Add 1.0 M NaNO ₃	

Study questions:

1. When Fe(NO₃)₃ was added to the system,

(a)Which ion in the equilibrium system caused the "stress"?

b) Which way did the equilibrium shift?

(c)What happened to the concentration of SCN⁻?

(d) What happened to the concentration of FeSCN²⁺?

2. When NaSCN was added to the system,

Which ion in the equilibrium system caused the "stress"?

Which way did the equilibrium shift?

What happened to the concentration of Fe³⁺?

What happened to the concentration of FeSCN²⁺?

3. When AgNO₃ was added to the system, it caused the precipitation of solid AgSCN.

Which ion in the equilibrium had its concentration changed by addition of AgNO₃?

Did the concentration of that ion increase or decrease?

When AgNO₃ was added, which way did the equilibrium shift?

4. When you added NaNO₃, did anything happen? Can you explain this result?

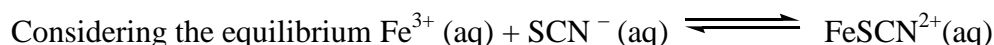

If the concentration of either Fe³⁺ or SCN⁻ is increased, the equilibrium shifts to right to reduce the concentration of the added reactant. Similarly, if FeSCN²⁺(aq) is added to the equilibrium, the position of the equilibrium will shift to the left to reduce the concentration of FeSCN²⁺(aq) according to Le Châtelier's principle.

Note that if silver nitrate solution is added to the equilibrium, it supplies silver ions (Ag^+) which removes cyanide ions (SCN^-) and causes the equilibrium to shift from right to left to replace the cyanide ions. All the the equilibrium shifts are indicated by color changes since they occur at molecular level.

According to Le Châtelier's principle, if the concentration of reactants is increased, the reaction will shift in the forward direction. Adding a reactant or product, the equilibria shifts away from the increase in order to consume the part of the added substance. By removing a reactant or product, the equilibria shifts toward the decrease to replace part of the removed species.

Consider the following equilibrium reaction:

$$\text{N}_2(\text{g}) + 3\text{H}_2(\text{g}) \rightleftharpoons 2\text{NH}_3(\text{g})$$

If we add either N_2 or H_2 , the collisions between N_2 and H_2 are increased and more product NH_3 are formed. It means that the equilibrium shifts from left to right. However, if more NH_3 are added, the concentration of NH_3 is increased. As a result, some NH_3 decomposes and forms more reactants. The equilibrium shifts from right to left.

Checking up 15.3.2

1. Explain Le Châtelier's principle
2. What factors did Fritz Haber employ to determine the changing positions of equilibrium reactions?
3. Determine what would happen to the following reactions if the concentration of any one of the reactants is increased or decreased?

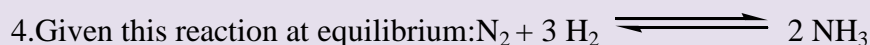
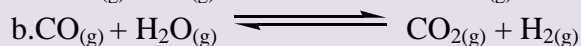

In which direction—toward reactants or toward products—does the reaction shift if the equilibrium is stressed by each change?

(a) H_2 is added.

(b) NH_3 is added.

(c) NH_3 is removed.

15.3.3. Effect of Changing Pressure

Activity 15.5.3.3

Consider the reaction: $\text{CaCO}_3 (\text{s}) \rightleftharpoons \text{CaO} (\text{s}) + \text{CO}_2 (\text{g})$ which takes place in a closed container,

1. Compare the molecules of carbon dioxide in both (a) and (b) in the diagram below
2. Why is there change in the number of molecules in both diagrams?
3. What can you do to make sure the molecules in (b) go back to their original number as in a.

4. Assume the reaction: $\text{N}_2 + 3\text{H}_2 \rightleftharpoons 2\text{NH}_3$,

What would happen if the pressure was increased in the above equilibrium? Explain your prediction.

5. Why is unreacted hydrogen and nitrogen recycled back into the heat exchanger?

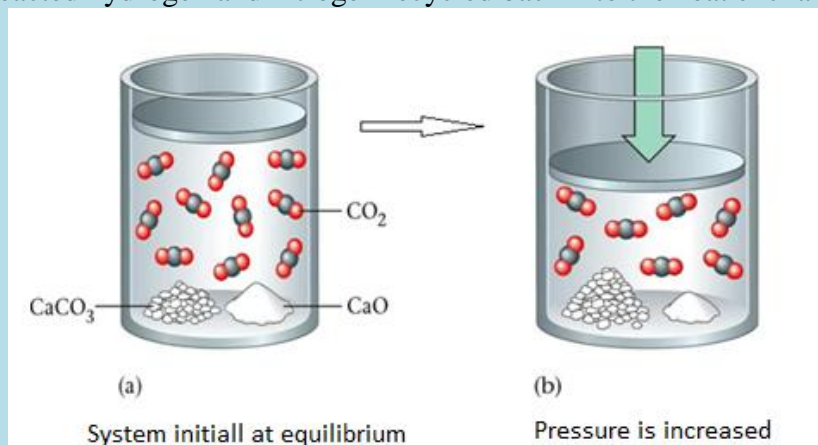

According to Le Châtelier's principle, an increase in pressure favours the reaction in the direction where the volume of reactants is reduced and a decrease in pressure favours the reaction in the direction where the volume of reactants is increased.

Example

Consider the reaction:



1 unit of
volume

3 unit of
volume

2 unit of
volume

Because the pressure of gases is related directly to the concentration by $P = n/V$, changing the pressure by increasing/decreasing the volume of a container will disturb an equilibrium system. In the above example, the volume of reactants is 4 units while the volume of products is 2 units. Therefore, according to Le Châtelier's principle an increase in pressure of this reaction will favor the forward reaction to form fewer ammonia while a decrease in pressure of the reaction will favor the backward reaction to form more nitrogen and hydrogen.

Increase in pressure $\xrightarrow{\hspace{10em}}$ shifts the equilibrium in the direction of decreased volume

Decrease in pressure $\xrightarrow{\hspace{10em}}$ shifts the equilibrium in the direction of increased volume

To obtain much ammonia in the equilibrium mixture, a high pressure of 200 atmospheres is needed.

The effect of pressure can be summarized by the graph indicated below

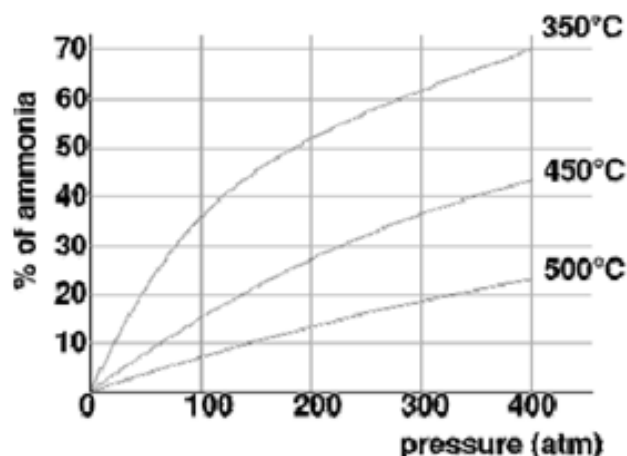

Figure 15.5: Graph of percentage yield changing with increase in pressure

High Pressure gives a good yield of ammonia as indicated from the graph above, at 400 atmospheres the yield of ammonia is 70%

Higher pressure increases the rate of reaction

However, the higher the pressure used, the higher the cost of the equipment needed to withstand the pressure.

The higher the pressure the higher the electrical energy costs for pumps to produce the pressure.

A moderately high pressure of between 200 – 1000 atmospheres is used.

Checking up 15.3.3

Determine whether the following reactions are favored by high or low pressures?

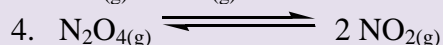
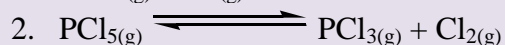

6. (a) What is the effect on this equilibrium if pressure is increased?

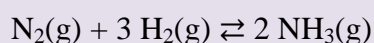

(b) What is the effect on this equilibrium if pressure is decreased?

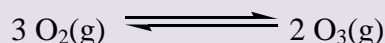

15.3.4. The effect of a catalyst on equilibrium

Activity 15.3.4

1. What is an enzyme?
2. What is a catalyst? Name the catalyst used in the Haber process and contact process
2. What would happen if the enzymes involved in the digestion of food were not present?
3. Most of the metabolic processes in the body are controlled by enzymes. What would happen to these metabolic processes if the enzymes were missing?

The function of a catalyst is to speed up the reaction by lowering the activation energy. The catalyst lowers the activation energy of the forward reaction and reverse reaction to the same extent. Adding a catalyst doesn't affect the relative rates of the two reactions and therefore the catalyst has no effect on the equilibrium system. The catalyst does not appear in the overall equation of the reaction.

Checking up 15.3.4

1. Sulphuric acid is produced by the contact process.

Stage 1: Sulphur is burnt in air



Stage 2: Sulphur dioxide is reacted with oxygen



Stage 3: Sulphur trioxide is dissolved in concentrated sulphuric acid

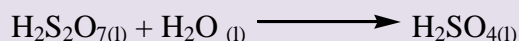
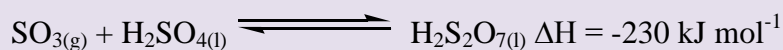

Stage 3 constantly removes the SO_3 formed in stage 2.

- (a) What effect does this have the position of equilibrium in stage 2?
- (b) What effect would increasing temperature and pressure have on the yield of SO_3 and the rate of reaction?
- (c) A V_2O_5 catalyst is used. What effect it have on the yield of SO_3 and the rate of reaction?
- (d) Why is the concentration of SO_2 kept high?
- (e) The conditions used are 450°C (moderately high) and 10 atmospheres
- (f) Why is this temperature used?
- (g) Why is a much higher pressure not used?

2. Hydration of ethene is indicated by the reaction below



The Essential Conditions for the above reaction are:

High temperature 300 °C (moderate temp)

High pressure 70 atmospheres (moderate pressure)

Strong acidic catalyst of concentrated H_3PO_4

Describe why are these conditions have been chosen

3. The following reaction is exothermic.

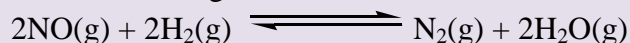

In which direction does the equilibrium shift as a result of each change?

(a) Removing the hydrogen gas

(b) Increasing the pressure of gases in the reaction vessel by decreasing the volume

(c) Increasing the pressure of gases in the reaction vessel by pumping in argon gas while keeping the volume of the vessel constant

(d) Increasing the temperature

(e) Using a catalyst

4. The reaction $2\text{SO}_2(\text{g}) + \text{O}_2(\text{g}) \rightleftharpoons 2\text{SO}_3(\text{g})$ reaches dynamic equilibrium in a closed vessel. The forward reaction is exothermic. The reaction is catalyzed by V_2O_5 .

(a) Explain the term dynamic equilibrium.

(b) What will happen to the position of equilibrium when:

(i) Some sulfur trioxide, SO_3 , is removed from the vessel?

(ii) The pressure in the vessel is lowered?

(iii) More V_2O_5 is added?

(iv) The temperature of the vessel is increased?

(c) State Le Châtelier's principle.

(d) Use Le Châtelier's principle to explain what will happen to the position of equilibrium in the reaction $\text{H}_2(\text{g}) + \text{CO}_2(\text{g}) \rightleftharpoons \text{H}_2\text{O}(\text{g}) + \text{CO}(\text{g})$ when the concentration of hydrogen is increased.

15.4. End unit assessment

1. Consider the following equilibrium reaction: $\text{N}_2(\text{g}) + 3\text{H}_2(\text{g}) \rightleftharpoons 2\text{NH}_3(\text{g})$

(a) What happens if we increase the concentration of N_2 by adding more N_2 ?

(b) What happens if we increase the concentration of H_2 by adding more H_2 ?

(c) What happens if we increase the concentration of NH_3 by adding more NH_3 ?

(d) What happens if we decrease the concentration of N_2 by removing some N_2 ?

(e) What happens if we decrease the concentration of H_2 by removing some H_2 ?

(f) What happens if we decrease the concentration of NH_3 by removing some NH_3 ?

2. Read the passage and answer the questions that follow

carbon dioxide and formation of Stalactites and Stalagmites in limestone caves

In addition to being a component of the atmosphere, carbon dioxide also dissolves in the water of

the oceans. The dissolving process can be described by the following equations



In nature, surface water often becomes acidic because atmospheric carbon dioxide dissolves in it. This acidic solution can dissolve limestone.



Openings formed in the limestone as the calcium carbonate dissolves

Slight cooling of the water saturated with carbon dioxide can reduce the solubility of the carbon dioxide. The position of the equilibrium shifts, resulting in the precipitation of calcium carbonate. This precipitate, the stalactite is formed immediately when the seeping water comes in contact with air currents in a cave. Stalagmites form on the floors of the caves in the same way.

a) Suggest why the balance between $\text{CO}_2(\text{g})$ in the atmosphere and $\text{CO}_2(\text{aq})$ in the oceans cannot be regarded as a true dynamic equilibrium.

The system is not closed.

b) Based on equations (1) and (2), explain the likely effect of the increasing concentration of atmospheric carbon dioxide on the pH of water at the ocean surface.

Part B

c) Use Le Châtelier's principle to explain why slight cooling of the water saturated with carbon dioxide will result in the precipitation of calcium carbonate.

3. The hydrogen used in the Haber process is made by the following reaction:



Discuss how the yield of hydrogen in the process is affected by changing the pressure, changing the temperature

and using a catalyst. (For this question, you are required to give answers in paragraph form.)

4. Read the following passage and answer the questions that follow.

Chlorine for disinfection

Chlorine is used in water treatment for disinfection.

When chlorine is added to pure water, hypochlorous acid (HOCl) and hydrochloric acid (HCl) are formed.

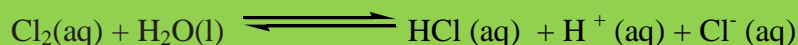

The principal disinfecting action of aqueous chlorine is due to hypochlorous acid formed.

Hypochlorous acid is dissociated into hydrogen ions and hypochlorite ions



The concentration of hypochlorous acid and hypochlorite ions in chlorine water depend on the pH of water. Instead of using chlorine gas, some plants apply sodium hypochlorite or calcium

hypochlorite in water. Sodium hypochlorite completely dissociate in water to form sodium ions and hypochlorite ions. In solution, the hypochlorite ions hydrolyze to form the disinfectant hypochlorous acid according to the following equation.



a) State Le Châtelier's principle.

b) Use Le Châtelier's principle to explain how the pH of the chlorinated water will affect the concentrations of hypochlorous acid and hypochlorite ions in the water.

d) The hypochlorous acid produced in a solution of sodium hypochlorite can react further to produce small amount of chlorine according to the following equation:

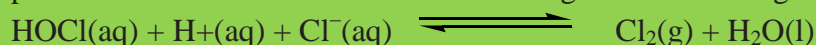

What will happen to the concentration of chlorine if a little sodium hydroxide solution is added to sodium hypochlorite solution? Explain your answer.

5. In the Contact process, sulphur dioxide is catalytically oxidized to sulphur trioxide according to the equation:



The following table summarizes several possible conditions for the preparation of sulphur trioxide:

case	Conditions		
	reactants	Pressure /atm	Temperature/ °C
A	SO ₂ (g) + excess O ₂ (g)	500	400
B	excess SO ₂ (g)+ O ₂ (g)	500	1000
C	excess SO ₂ (g)+ air	1	1000
d	SO ₂ (g) + excess air	1	400

Which of the cases would represent?

(a) The theoretical conditions for obtaining the maximum yield of sulphur trioxide? Explain your answer.

b) the most economical conditions for the industrial preparation of sulphur trioxide? Explain your answer.

6. Ethanol is manufactured by catalytic hydration of ethene:



a) The reaction represented by the above equation can reach a position of dynamic equilibrium..State two features of a system that is in dynamic equilibrium.

(b)The following table lists the percentage conversion of ethene using excess steam at various reaction conditions used in industry.

Pressure /atm	Temperature/ °C	Percentage conversion / %
50	200	45
50	320	30
80	200	60
80	320	45

i) State and explain the effect of increasing the pressure on the percentage conversion.

ii) Deduce the sign of the enthalpy change for the forward reaction. Explain your answer.

iii) The equation for the formation of ethanol shows that equal numbers of moles of ethene and

steam are required. In industry however excess steam is used.

(c) Suggest why excess steam is used.

7. The following reaction is exothermic.



In which direction does the equilibrium shift as a result of each change?

- (a) Removing the hydrogen gas
- (b) Increasing the pressure of gases in the reaction vessel by decreasing the volume
- (c) Increasing the pressure of gases in the reaction vessel by pumping in argon gas while keeping the volume of the vessel constant
- (d) Increasing the temperature
- (e) Using a catalyst

8. The reaction $2\text{SO}_2(\text{g}) + \text{O}_2(\text{g}) \rightleftharpoons 2\text{SO}_3(\text{g})$ reaches dynamic equilibrium in a closed vessel. The forward reaction is exothermic. The reaction is catalyzed by V_2O_5 .

- (a) Explain the term dynamic equilibrium.
- (b) What will happen to the position of equilibrium when:
 - (i) Some sulfur trioxide, SO_3 , is removed from the vessel?
 - (ii) The pressure in the vessel is lowered?
 - (iii) More V_2O_5 is added?
 - (iv) The temperature of the vessel is increased?
- (c) State Le Châtelier's principle.
- (d) Use Le Châtelier's principle to explain what will happen to the position of equilibrium in the reaction $\text{H}_2(\text{g}) + \text{CO}_2(\text{g}) \rightleftharpoons \text{H}_2\text{O}(\text{g}) + \text{CO}(\text{g})$ when the concentration of hydrogen is increased.

UNIT 16: ACIDS AND BASES

Key unit Competence: Explain the concept of energy changes and energy profile diagrams for the exothermic and endothermic processes.

Learning Objectives:

By the end of this unit, I will be able to:

- Explain the concept of acid and base using Arrhenius, Brønsted-Lowry and Lewis' theory.
- Distinguish strong acids from weak acids and strong bases from weak bases using Brønsted-Lowry theory.
- Classify the acids and bases as strong or weak according to their dissociation in aqueous solution.
- Distinguish between Brønsted-Lowry and Lewis' Acid-Base theories.
- Write the dissociation of acids and bases and identify the acid-base conjugate pairs.
- Exhibit the team working spirit.
- Demonstrate self-confidence during group discussions and presentation of the findings.

Introductory activity 16

1. Have you heard the words acid and base? Yes or No. If yes what do they mean? Give an example of an acid and an example of a base?
2. Observe the pictures shown below. Identify the name and main use(s) of the substance in each picture.



3. Answer the following questions using information given in question 2.
- Match the names of substance in question 2 with the ones in the following table.
 - In how many main group would you classify the substance above?
 - Name the groups you referred to in 2 (ii)?

Substance	pH range
Butter	6.1-6.4
Soap	9-10
Citric acid	2.2-2.4
Magnesium hydroxide	≈ 10.5
Pepper	4.6-5.5

Acids were first recognized as a class of substances that taste sour. Vinegar tastes sour so because it contains acetic acid; citric acid is responsible for the sour taste of a lemon. Bases, sometimes called alkalis, are characterized by their bitter taste and slippery feel. The bitter taste of quinine or extract from some plants such as *Vernonia amygdalina* (Umubirizi) are characteristics of bases. Commercial preparations for unclogging drains are highly basic.

16.1 Acid-Base Theories

Activity 16.1 Determining the acidity/alkalinity nature of substance using acid-base indicators.

Procedure

Using a dropper, collect 3-4 drops of each of the 7 chemical substances in 7 test tubes.

- Hydrochloric acid (HCl)
 - Sodium hydroxide (NaOH)
 - Sodium chloride (NaCl)
 - Glucose (C₆H₆O₁₂)
 - Sulphuric acid (H₂SO₄)
 - Distilled water (H₂O)
 - Ammonia (NH₃).
 - Ethanoic acid (CH₃COOH)
- To each chemical test whether it is an acid, a base or neutral by using blue litmus paper, red litmus paper and universal indicator (better). Record your observations and colour intensities in Table 16.1.
 - Comparing the colour intensities of the indicators, explain the source their difference.

Results

Table 16.1. Results of acid-base testing

Reagent	Red Litmus	Blue Litmus	Acid, base or neutral?
Hydrochloric acid (HCl)			

Sodium hydroxide (NaOH)			
Sodium chloride (NaCl)			
Distilled water (H ₂ O)			
Glucose (C ₆ H ₁₂ O ₆)			
Sulphuric acid (H ₂ SO ₄)			
Ammonia (NH ₃)			
Ethanoic acid(CH ₃ COOH)			

Study Questions

1. Which of the chemicals are acids?
2. Which of the chemicals are bases?
3. Which of the chemicals are neutral?

16.1.1. Arrhenius' Theory of Acid-Base

The first person to recognize the essential nature of acids and bases was the Swedish scientist **Svante Arrhenius** (1859–1927). On the basis of his experiments with electrolytes, Arrhenius postulated that acids produce hydrogen ions in aqueous solution, while bases produce hydroxide ions.

- (i) **An acid** is a substance which dissociates in aqueous solution to produce hydrogen ions (H⁺) as the only positive ions
- (ii) **A base** is any substance that dissociates in aqueous solution to produce hydroxyl ions (OH⁻) as the only negative ions.

Notice that the Arrhenius concept of acid and base requires the presence of water.

In this theory, the products of an acid-base reaction are: salt and water:

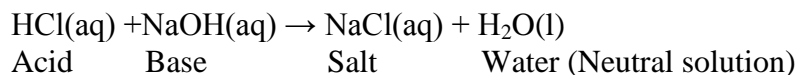

This reaction acid-base shows that when an acid reacts with a base, the result is a neutral solution of a salt in water; this explains why the reaction is called an **acid-base neutralization reaction**: acidic properties and basic properties neutralize each other.

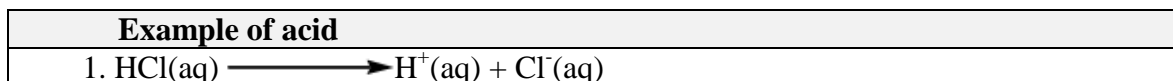

2. $\text{H}_2\text{SO}_4(\text{aq}) \longrightarrow 2\text{H}^+(\text{aq}) + \text{SO}_4^{2-}(\text{aq})$
Example of base
1. $\text{NaOH}(\text{aq}) \longrightarrow \text{Na}^+(\text{aq}) + \text{OH}^-(\text{aq})$
2. $\text{Mg}(\text{OH})_2(\text{aq}) \longrightarrow \text{Mg}^{2+}(\text{aq}) + 2\text{OH}^-(\text{aq})$

Notice

The observations in activity 16.1 show that all acids and bases do not show the same intensity of colours ; this means that although all are acids or bases they give different concentrations of H^+ or OH^- ions.

This means that not all acids and bases dissociate into their ions at the same extent. Some dissociate completely in water, other dissociate partially.

Acids and bases that dissociate completely into their ions when dissolved in water are qualified as “**strong**”.

Examples of strong acid and strong base:

$\text{HCl}(\text{aq}) \rightarrow \text{H}^+(\text{aq}) + \text{Cl}^-(\text{aq})$ **strong acid, complete dissociation into ions**

$\text{NaOH}(\text{aq}) \rightarrow \text{Na}^+(\text{aq}) + \text{OH}^-(\text{aq})$ **strong base, complete dissociation into ions**

Acids and bases that dissociate partially in water are qualified as “**weak**”:

Examples of weak acid and weak base:

$\text{H}_3\text{PO}_4(\text{s}) + \text{H}_2\text{O}(\text{l}) \rightleftharpoons \text{H}^+(\text{aq}) + \text{H}_2\text{PO}_4^-(\text{aq})$ **partially dissociated, weak acid.**

$\text{NH}_4\text{OH}(\text{aq}) + \text{H}_2\text{O}(\text{l}) \rightleftharpoons \text{NH}_4^+(\text{aq}) + \text{OH}^-(\text{aq})$ **partially dissociated, weak base.**

Since strong acids and strong bases dissociate completely in water whereas weak acids and weak bases dissociate partially, the concentration $[\text{H}^+]$ in a solution of a strong acid will be higher than the concentration $[\text{H}^+]$ in the solution of a weak acid of the same concentration; in other words pH of the strong acid solution will be lower than pH of the weak acid solution of the same concentration.

For the same concentration: $\text{pH of HCl}(\text{aq}) < \text{pH of H}_3\text{PO}_4(\text{aq})$

In the same way, the concentration OH^- in a strong base solution will be higher than the concentration OH^- of a weak base solution of the same concentration; in this case the concentration H^+ in a strong base solution will be lower than the concentration H^+ in a weak base solution of the same concentration, or pH of strong base solution will be higher than pH of the weak base solution of the same concentration.

For the same concentration: $\text{pH of NaOH}(\text{aq}) > \text{pH of NH}_4\text{OH}(\text{aq})$.

Checking up 16.1(a)

1. Fill in the following table

Substance	Acid/Base	Positive ions in water	Negative ions in water
HCl			
HBr			
HNO_3			
KOH			
$\text{Ca}(\text{OH})_2$			

NH ₄ OH			
HCOOH			

2. Use the information in the following table to answer the following questions.

Table 16.2 The pH Values of Some Common Solutions^(*)

Solution	pH / pH range
Battery acid	0.3
Stomach acid	1–2
Lemon or lime juice	2.1
Vinegar	2.8–3.0
Coca-Cola	3
Wine	2.8–3.8
Beer	4–5
Coffee	5
Milk	6
Urine	6
Pure H ₂ O	7
(Human) blood	7.3–7.5
Sea water	8
Antacid (Milk of magnesia)	10.5
NH ₃ (1 M)	11.6
Bleach	12.6
NaOH (1 M)	14.0

^(*)Adapted from: <https://chem.libretexts.org>

- a. Two strongest acidic substances
- b. Two weakest acidic substances
- c. Two most alkaline substances
- d. Two least alkaline substances
- e. Neutral substance (s).

3.

- (i) Take two different solutions with equal concentrations of acids such as HCl and CH₃COOH, and measure their pHs.
- (ii) Take two different solutions with equal concentrations of bases such as NaOH and NH₄OH, and measure their pHs.

Questions:

- a. What are the observations about the results?
- b. How do you interpret those results?

16.1.2. Brønsted-Lowry's Acid-Base Theory: Acid-base conjugate pairs

In 1923, the Danish Chemist Johannes Nicolaus (1879–1947) and English Chemist Thomas Martin Lowry (1874 – 1936) independently developed the definitions of acids and bases based on the compounds' abilities to either donate or accept protons (H^+ ions). In this theory, acids are defined as proton donors whereas bases are defined as proton acceptors. A compound that acts as both a Brønsted-Lowry acid and base is called *amphoteric*.

Briefly in this theory, **an acid is a proton (H^+) donor**, and **a base is a proton acceptor**.

Examples

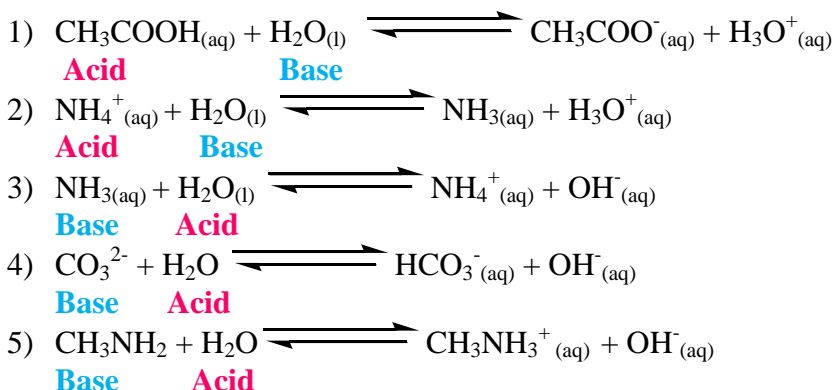

Let us consider an acid HA which ionizes partially in aqueous solution according to a reversible reaction below:

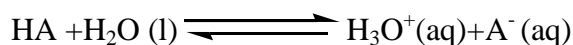

- *Forward reaction:*

HA is an acid because it is donating a proton to H_2O .

The water (H_2O) is a base because it is accepting a proton from the acid (HA).

- *Reverse reaction*

The H_3O^+ is an acid because it is donating a proton to the A^- ion.

The A^- ion is a base because it is accepting a proton from the H_3O^+ . The reversible reaction contains *two* acids and *two* bases. We take them as pairs, called *conjugate pairs*.

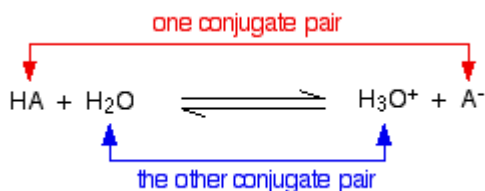

According to the forward reaction, HA is the acid and its conjugate base is A⁻. According to the reverse reaction, H₃O⁺ is an acid whose conjugate base is H₂O.

The above reaction can be represented as:

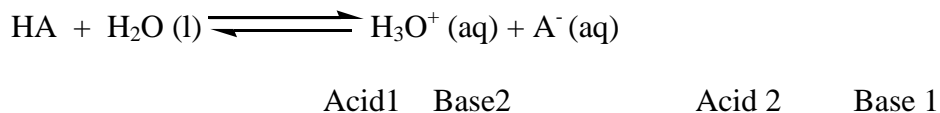

The acid-base conjugate pairs are written as Acid1/ Base 1 and Acid 2/ Base2.

Examples

- 1) When an acid loses a proton a **conjugate base** is produced.

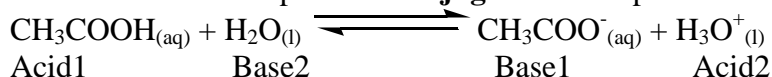

The conjugate acid-base pairs for this reaction are the following:



- 2) $\text{NH}_3(\text{aq}) + \text{H}_2\text{O}(\text{l}) \rightleftharpoons \text{NH}_4^+(\text{aq}) + \text{OH}^-(\text{aq})$
- Base1
Acid2
Acid1
Base2

The conjugate acid-base pairs for this reaction are NH₄⁺/ NH₃ and H₂O/ OH⁻.

In general, when an acid is strong, its conjugate base is weak and vice-versa.

Examples:

In the reaction above, HCl is a strong acid, the conjugate base Cl⁻ is weak; similarly, H₂O is a weak base and its conjugate acid H₃O⁺ is strong.

In the conjugate acid base couples of the previous example:

NH₄⁺/NH₃: NH₄⁺ is a strong acid whereas NH₃ is a weak base.

H₂O/OH⁻: H₂O is a weak acid whereas OH⁻ is a strong base.

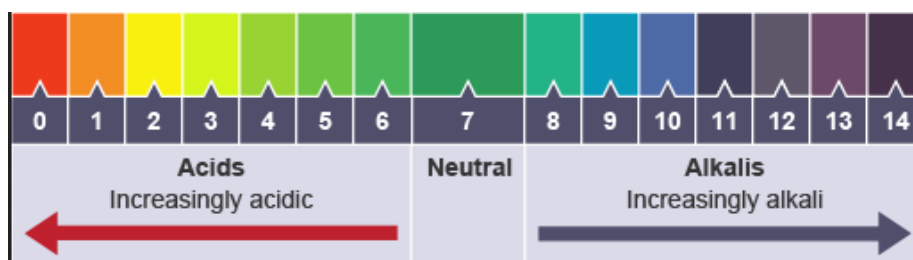
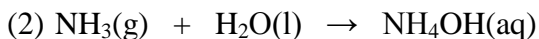

Figure16. pH scale

Remarks

- (i) The observation of the above examples shows that water can act as both Brønsted-Lowry base or a Brønsted-Lowry acid. Thus, water is known as an **amphoteric solvent**.
- (ii) In this theory, OH⁻ ion is a proton acceptor as any other proton acceptor; hence it is a base among other bases, not the only base.
- (iii) The theory does not require the presence of any specific medium.





In these two situations, in (1), gaseous HCl is an acid because it donates H^+ ion to gaseous NH_3 , hence gaseous ammonia is base since it is a proton acceptor to form NH_4^+ ion; in (ii), gaseous NH_3 accepts a proton from water to form $\text{NH}_4\text{OH}(\text{aq})$, hence it is base and water is an acid, a proton donor.

Checking up 16.1 (b)

1. Label the acid (A), base (B), conjugate acid (CA), and conjugate base (CB) in each of the following reactions.

- $\text{HCl}(\text{aq}) + \text{H}_2\text{O}(\text{l}) \rightleftharpoons \text{H}_3\text{O}^+(\text{aq}) + \text{Cl}^-(\text{aq})$
- $\text{H}_2\text{PO}_4^-(\text{aq}) + \text{NH}_3(\text{aq}) \rightleftharpoons \text{NH}_4^+(\text{aq}) + \text{HPO}_4^{2-}(\text{aq})$
- $\text{NH}_4^+(\text{aq}) + \text{CN}^-(\text{aq}) \rightleftharpoons \text{HCN}(\text{aq}) + \text{NH}_3(\text{aq})$
- $\text{H}_2\text{SO}_4(\text{aq}) + \text{H}_2\text{O}(\text{l}) \rightleftharpoons \text{H}_3\text{O}^+(\text{aq}) + \text{HSO}_4^-(\text{aq})$

2. Give the conjugate base for each of the following Brønsted-Lowry acid.

- HI
- NH_4^+
- H_2CO_3
- HNO_3

3. Give the conjugate acid for each of the following Brønsted-Lowry bases.

- CN^-
- O^{2-}
- CH_3COO^-
- NH_3

16.1.3. Lewis's Acid-Base Theory

In 1938, an American chemist **Gilbert Newton Lewis** (1875–1946) introduced another theory which extends the concept of acids and bases further than those of Arrhenius and Brønsted-Lowry.

An acid is a chemical species that has a vacant orbital and can accept a pair of electrons from another chemical species. **An acid is an electron pair acceptor or electron deficient.**

In this theory, hydrogen ion, H^+ , is electron deficient and can accept a pair of electrons as any electron deficient species; it is no more the only responsible of acidic properties.

Other various species can act as Lewis acids. They include the following chemical species.

- All cations, but particularly cations of transition metals

e.g. Cu^{2+} , Fe^{2+} , Fe^{3+} .

- Chemical molecules whose central atom does not fulfill the octet rule

e.g. BF_3 , AlCl_3 , BH_3 , ...

A base is a substance that possesses one or more lone pairs of electrons which may be used for the formation of a coordinate bond. **A base is an electron pair donor.**

A Lewis base can be an anion, such as OH^- , Cl^- , CN^- or a neutral molecule with lone pair of electrons such as $\text{H}_2\ddot{\text{O}}$, $:\text{NH}_3$, etc...

Examples

- 1) The reaction between ammonia, NH_3 , H_2O with H^+ , to form ammonium ion, NH_4^+ :



Electron pair donor (Lewis base) Electron deficient (Lewis acid)



Lewis base Lewis acid

- 2) The reaction between ammonia, NH_3 , and boron trifluoride, BF_3 , involves a Lewis acid, BF_3 , and a Lewis base, NH_3 , according to the following reaction:

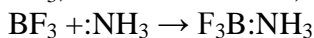

- 3) The formation of complex ions by transition metals is an example of reactions involving Lewis acids and Lewis bases. For instance, consider the following reactions:



Checking up 16.1(c)

- 1) Write equations of reactions between the following species and state the corresponding acids and bases.
- Fe^{3+} and H_2O to form hexaaquairon (III).
 - Cu^{2+} and NH_3 to form tetraamminecopper (II).
 - Cr^{3+} and H_2O to form hexaaquachromium (III).
- 2) What is the name of the bond formed between a Lewis acid and a Lewis base?
(a) Covalent bond (b) Double bond (c) Coordinate covalent bond (d) Ionic bond
- 3) Why is BH_3 (boron trihydride) a Lewis Acid? Identify the correct answer.
- It is a cation.
 - It is electron deficient.
 - It can accept more than 8 valence electrons.
 - It contains double bonds.

16.2. End unit Assessment

- Write an equation for the dissociation of the following acids in water:
a) HClO_4 b) H_2SO_4 c) CH_3COOH d) H_2S e) HNO_3
- Write the balanced reaction for what happens when nitric acid is put in water.
- Write the balanced reaction for what happens when acetic acid is put in water.
- Write an equation for the dissociation of $\text{Ba}(\text{OH})_2$ in water.
- What is the conjugate base of HSO_4^- ?
- Write the formula **and** name for the conjugate acid for the following bases:
a) NH_3 b) PO_4^{3-} c) CN^- d) HCO_3^-
- Write a balanced equation for the Bronsted-Lowry acid HPO_4^{2-} in water.
- Write and balance the reaction for ammonia in water.
- The acidity strength of group VII oxoacids increases with the number of oxygen atoms. With reference to Bronsted-Lowry theory of acids and bases, rank their conjugate bases hereafter in increasing order of alkalinity strength.
a) ClO^- b) ClO_2^- c) ClO_3^- d) ClO_4^-
- Rank the following chemical species in decreasing order of acidity strength.

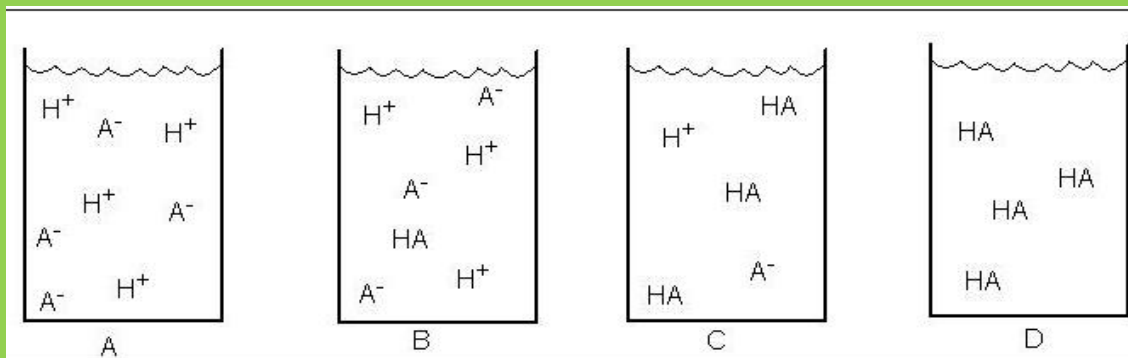

UNIT17: REDUCTION AND OXIDATION REACTIONS

Key unit competency: Explain the concept of reduction and oxidation and balance equations for redox reactions

Learning Objectives

By the end of this unit, a learner should be able to

- Explain the redox reactions in terms of electron transfer and changes in oxidation state (number)
- Explain the concept of disproportionation
- Differentiate the reducing agent from the oxidizing agent in a redox reaction
- Work out the oxidation numbers of elements in the compounds.
- Perform simple displacement reactions to order elements in terms of oxidizing or reducing ability.
- Apply half-reaction method to balance redox reactions.
- Deduce balanced equations for redox reactions from relevant half equations.

Introductory activity 17

The following figures illustrate the natural electrochemical process that is occurring on the surface of the metals. The figure A shows what we observe before and after the said process and the figure B shows what really happened chemically. Observe each of them carefully and answer the questions.



→

Figure A

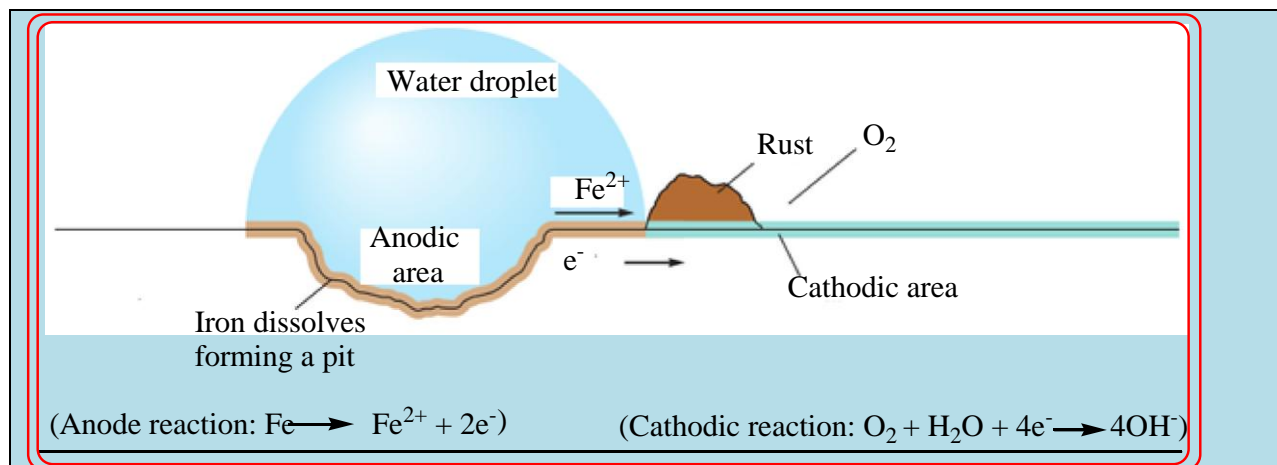

Figure B

1. What does figure A represent?
2. Based on some features shown on the figures above, suggest the name of the phenomenon that is happening to the figures
3. Write the overall chemical equation of the reaction that took place during the process
4. What are the conditions for the process shown to occur?
5. Is this process reversible? Explain.
6. Discuss the economic impact of this process and suggest how it should be prevented.

17.1. Definition of electrochemistry and its relationship with redox reactions.

Activity 17.1.

1. Use examples to differentiate redox reactions from other chemical reactions
2. Explain this statement: “Electrochemistry is a chapter of chemistry that studies the chemical reactions that produce electricity”

Electrochemistry is defined as *the study of the interchange of chemical and Electrical energy*. It is primarily concerned with two processes that involve oxidation–reduction reactions: the generation of an electric current from a spontaneous chemical reaction and, the opposite process, the use of a current to produce chemical change.

Electrochemistry is important in other less obvious ways. For example, the corrosion of iron, which has tremendous economic implications, is an electrochemical process. In addition, many important industrial materials such as aluminum, chlorine, and sodium hydroxide are prepared by electrolytic processes.

Checking up 17.1

1. Classify each of the following reactions as a precipitation, acid–base neutralization, simple displacement, double replacement, decomposition or oxidation–reduction:
 - a) $\text{Hg}(\text{NO}_3)_{2(\text{aq})} + 2 \text{NaI}_{(\text{aq})} \rightarrow 2 \text{NaNO}_{3(\text{aq})} + \text{HgI}_{2(\text{s})}$
 - b) $2 \text{HgO}_{(\text{s})} \rightarrow 2 \text{Hg}_{(\text{l})} + \text{O}_{2(\text{g})}$
 - c) $\text{H}_3\text{PO}_{4(\text{aq})} + 3 \text{KOH}_{(\text{aq})} \rightarrow \text{K}_3\text{PO}_{4(\text{aq})} + 3 \text{H}_2\text{O}_{(\text{l})}$

2. Which of the following transformations is a redox reaction?

- a) $\text{Ag}^+_{(\text{aq})} + \text{Cl}^-_{(\text{aq})} \rightarrow \text{AgCl}_{(\text{s})}$
- b) $\text{Na}_2\text{CO}_{3(\text{aq})} + 2\text{HCl}_{(\text{aq})} \rightarrow 2\text{NaCl}_{(\text{aq})} + \text{H}_2\text{O}_{(\text{aq})} + \text{CO}_{2(\text{aq})}$
- c) $\text{CaCO}_{3(\text{s})} \rightarrow \text{CaO}_{(\text{s})} + \text{CO}_{2(\text{g})}$
- d) $2\text{CaO}_{(\text{s})} \rightarrow 2\text{Ca}_{(\text{aq})} + \text{O}_{2(\text{g})}$

17.2. Definitions of reduction and oxidation reactions.

Activity 17.2

Compare the following definitions of oxidation and reduction and answer the questions related

Oxidation

- Gaining oxygen
- Losing hydrogen
- Losing electrons

Reduction

- Losing oxygen
- Gaining hydrogen
- Gaining electron

a) Suggest at least five chemical equations where oxidation and reduction reactions occurred

b) For chemical equations in (a), highlight the chemical species that have lose electrons and those that have gained electrons

c) Hence what can you conclude about oxidation and reduction reactions

17.2.1. Introduction

The name "oxidation" was initially applied to reactions where substances combined with the element oxygen. Thus any substance burning in air was said to be oxidized, the product being some type of oxide. For example, burning carbon to produce carbon dioxide is an oxidation, as shown by the equation

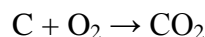

Subsequently it was realized that reactions of substances with elements other than oxygen were of essentially the same type. For example, hydrogen can react with oxygen to form the compound water, but equally it can react with chlorine to form the compound hydrogen chloride. In both reactions the free element hydrogen is converted into a compound of hydrogen and another non-metal, and in both reaction, hydrogen atom tends to lose an electrons whereas the other atoms tend to gain electron; so both were classified as oxidations even though no oxygen was involved in the second case.

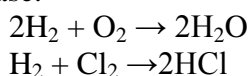

The reverse reaction, conversion of compounds such as oxides of metals to the elemental metal were called "reduction" reactions, for example, the reduction of copper (II) oxide to copper by heating with charcoal (carbon).

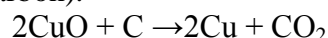

The gain or loss of oxygen is still a useful way of recognizing some oxidation or reduction reactions, but with knowledge of the structure of atoms, a rather different definition is now more widely used.

17.2.2. Oxidation reactions as a loss of electrons and reduction as a gain of electrons.

Let's take the reaction between magnesium, Mg, and chlorine (Cl₂):

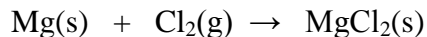

This reaction can be conceived into two parts, called half-reactions:

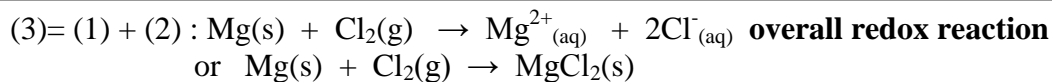

Hence a redox reaction is a combination of two half-reactions: an oxidation half-reaction and a reduction half-reaction. Nevertheless, one half-reaction cannot exist without another, because electrons lost in the oxidation process must be captured in the reduction process, this explains why we talk of oxidation-reduction or redox reaction.

The characteristic of a redox reaction is that there is exchange or transfer of electrons between chemical species participating in the reaction.

We can compare this to the emigration-immigration movement: when a person leaves a country, emigration for that country, he/she must enter another country, immigration for that country and this constitutes an emigration-immigration movement.

Checking up 17.2

1. Classify each of the following unbalanced half-reactions as either an oxidation or a reduction and justify

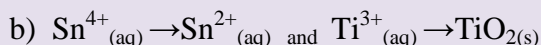
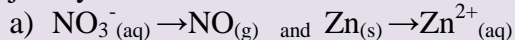

2. Write balanced oxidation and reduction half-reactions for the following processes

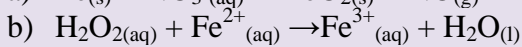
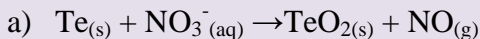

3. Which element is oxidized and which is reduced in each of the following reactions?

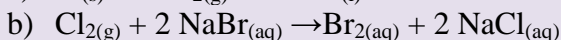
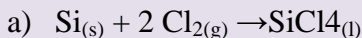

17.3. Explanation of oxidizing and reducing agents

Activity 17.3

1. Based on the positions in the periodic table, which of the following reactions would you expect to occur?

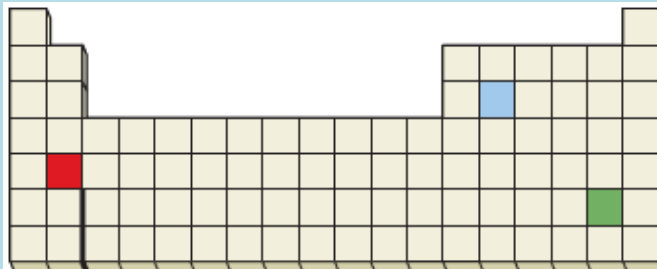

- (a) $\text{Red}^+ + \text{Green} \rightarrow \text{Red} + \text{Green}^+$
(b) $\text{Blue} + \text{Green}^+ \rightarrow \text{Green} + \text{Blue}^+$
(c) $\text{Red} + \text{Blue}^+ \rightarrow \text{Blue} + \text{Red}^+$

2. Aqueous copper (II) ion reacts with aqueous iodide ion to yield solid copper (I) iodide and aqueous iodine.
- Write the balanced net ionic equation,
 - Assign oxidation numbers to all species present, and
 - Identify the oxidizing and reducing agents.

Substances that cause changes in the oxidation state are called **Oxidizing agents** or **Reducing agents**. To increase the positive oxidation number of an element, the oxidizing agent must take one or more electrons from the element.

As the element being oxidized loses electron(s), its oxidation number increases. However, the electrons don't disappear. The oxidizing agent takes those electrons, and therefore the oxidation number of the oxidizing agent decreases.

Let us consider the reaction between hydrogen chloride solution and zinc metal.

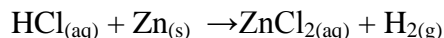

In the above reaction, hydrogen in hydrogen chloride takes an electron from the zinc metal. The oxidation state of zinc metal increases from 0 to +2; **it is oxidized**. By taking the electrons from zinc metal, the oxidation state of hydrogen decreases from +1 to 0; **it is reduced**.

Hydrogen chloride is the oxidizing agent, because it contains the element that causes oxidation to occur. Similarly, the zinc metal donates electrons to the hydrogen ion in hydrogen chloride, causing the oxidation state of hydrogen to decrease from +1 to 0. By providing the electrons necessary to reduce hydrogen ion, the oxidation number of zinc increases from 0 to +2.

Oxidizing agents are substances or chemical species containing the element(s) or species that accept electrons allowing another element(s) or species to be oxidized

By accepting electrons, the element(s) or species in the oxidizing agent are reduced.

Reducing agents are substances or chemical species containing the element(s) or species that donate electrons (oxidized), allowing another element(s) or species to be reduced.

By giving up electrons, the element(s) or species in the reducing agent are oxidised.

Table 17.1: Comparison between a reducing agent and an oxidizing agent

Reducing agent:	Oxidizing agent:
<ul style="list-style-type: none"> • Causes reduction • Loses one or more electrons • Undergoes oxidation; i.e. oxidation number of atom increases 	<ul style="list-style-type: none"> • Causes oxidation • Gains one or more electrons • Undergoes reduction, i.e. oxidation number of atom decreases

In general, metals give up electrons and act as reducing agents, while reactive nonmetals such as O₂ and the halogens accept electrons and act as oxidizing agents.

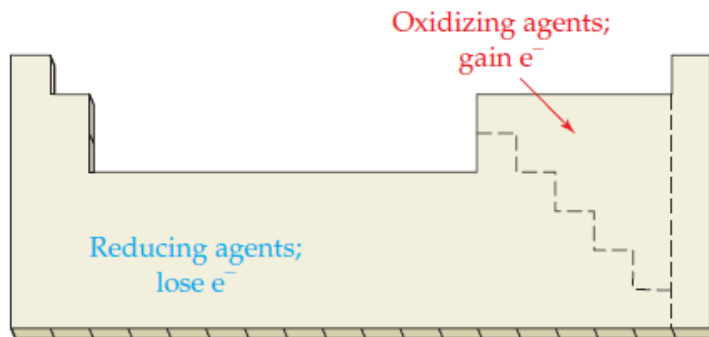

Checking up 17.3

In the following reactions, identify the oxidizing agent and reducing agent.

1. $\text{Fe}_{(s)} + \text{Ni}(\text{NO}_3)_{2(aq)} \rightarrow \text{Fe}(\text{NO}_3)_{2(aq)} + \text{Ni}_{(s)}$
2. $\text{Cu}_{(s)} + 4\text{HNO}_{3(aq)} \rightarrow \text{Cu}(\text{NO}_3)_{2(aq)} + 2\text{H}_2\text{O}_{(l)} + 2\text{NO}_{2(g)}$
3. $\text{CH}_{4(g)} + 2\text{O}_{2(g)} \rightarrow \text{CO}_{2(g)} + 2\text{H}_2\text{O}_{(l)}$
4. $\text{C}_2\text{H}_{4(g)} + \text{H}_{2(g)} \rightarrow \text{C}_2\text{H}_{6(g)}$
5. $\text{H}_2\text{SO}_{4(aq)} + 2\text{NaOH}_{(aq)} \rightarrow 2\text{Na}^+_{(aq)} + \text{SO}_4^{2-}_{(aq)} + 2\text{H}_2\text{O}_{(l)}$

17.4. Rules used to determine oxidation numbers of elements in chemical compounds and species

Activity 17.4

1. How can you tell when a redox reaction takes place?
2. Indicate the valence and the charge of each element in the following compounds:
H₂SO₄, HNO₃, PCl₃, PCl₅, NH₃, NaH, Na₂O, Na₂O₂
3. By using your prior knowledge, determine the oxidation number of the underlined elements in the following compounds
K2Cr2O7, Na2C2O4, KMnO4, MnSO4, CO2, CrCl3, NO, HNO3, SO3

The oxidation number of an atom is the apparent or real charge that the atom has when all bonds between atoms of different elements are assumed to be ionic. By comparing the oxidation number of an element or chemical species before and after reaction, we can tell whether the atom has gained or lost electrons. Note that oxidation numbers don't necessarily imply ionic charges; they are just a convenient device to help keep track of electrons during redox reactions.

The rules for assigning oxidation numbers are as follows:

1. The oxidation number of an element in its elemental form is 0 (zero).
2. In **compounds**, the oxidation number of oxygen is almost always -2 . The most common exception is in peroxides, when the oxidation number is -1 . Peroxides are compounds having two oxygen atoms bonded together. For example, hydrogen peroxide is H-O-O-H. In hydrogen peroxide, each oxygen atom has a -1 oxidation number. When Oxygen is bonded to fluorine, as in hypofluorous acid (HOF), the oxidation number of oxygen is 0. Oxygen-fluorine compounds such as OF_2 , the oxidation number of oxygen is $+2$.
3. The oxidation number of a simple ion is equal to the charge on the ion.
Note that the “+” and “-” signs are just as important as the number (they indicate the nature of the charge).
4. The oxidation numbers of group 1 and group 2 elements are $+1$ and $+2$ respectively.
5. In **compounds**, the oxidation number of hydrogen is almost always $+1$. The most common exception occurs when hydrogen combines with metals; in this case the oxidation number of hydrogen is typically -1 .
6. In **compounds**, the oxidation number of fluorine is always -1 . The oxidation number of other halogens (Cl, Br, I) is also -1 , except when they are combined with oxygen. The oxidation number of halides (except fluorine) combined with oxygen is typically positive. For example, in ClO^- , chlorine’s oxidation number is $+1$.
7. For a complex ion, the sum of the positive and negative oxidation numbers of all elements in the ion equals the charge on the ion.
8. For an electrically neutral compound, the sum of the positive and negative oxidation numbers of all elements in the compound equals zero. In any compound, the more electronegative atom has the negative oxidation number while the less electronegative atom has the positive oxidation number. For example in SCl_2 , sulfur has an oxidation number of $+2$ since it is less electronegative than chlorine but in sodium sulphide, Na_2S , its oxidation number is -2 .
9. **The sum of the oxidation numbers is 0 for a molecule and is equal to the net charge for a polyatomic ion.** This rule is particularly useful for finding the oxidation number of an atom in any chemical compound or species. The general idea is to assign oxidation numbers to the “easy” or known atoms first and then find the unknown oxidation number by calculation.

For example, suppose we need to know the oxidation number of the sulfur atom in sulfuric acid (H_2SO_4). Since each H atom is $+1$ and each O atom bears -2 , the S atom must have an oxidation number of $+6$ for the compound to have no net charge:

$$2(+1) + (?) + 4(-2) = 0 \text{ net charge}$$

$$? = 0 - 2(+1) - 4(-2) = +6$$

To find the oxidation number of the chlorine atom in the perchlorate anion (ClO_4^-), we know that each oxygen is -2 , so the Cl atom must have an oxidation number of $+7$ for there to be a net charge of -1 on the ion:

$$? + 4(-2) = -1 \text{ net charge}$$

$$? = -1 - 4(-2) = +7$$

Checking up 17.4

1. Assign oxidation numbers to each atom in the following substances

(a) CdS (b) AlH₃ (c) S₂O₃ (d) Na₂Cr₂O₇

(e) SnCl₄ (f) CrO₃ (j) VOCl₃

(h) V₂O₃ (e) HNO₃ (f) FeSO₄

2. Working using oxidation numbers only, determine whether the species underlined has undergone oxidation or reduction

a) C_(s) + H₂O_(g) → CO_(g) + H_{2(g)}

(b) 2Na_(s) + H_{2(g)} → 2NaH_(s)

(c) 2FeCl_{2(aq)} + Cl_{2(g)} → 2FeCl_{3(aq)}

3. What is the oxidation number of chromium in each of the following compounds or ions?

(a) Cr (b) CrO₃ (c) CrCl₃ (d) Cr₂O₃ (e) Cr₂O₇²⁻ (f) CrO₄²⁻

4. Identify in which of the following species nitrogen is in

(i) its lowest oxidation state

(ii) its highest oxidation state:

NO₂, NO, HNO₃, N₂, HNO₂, N₂O, Na₃N

17.5. Balancing of Redox equations

Activity 17.5

To study the redox reactions between iron(II) sulphate and hydrogen peroxide

Apparatus/materials

Iron powder, 2M sulphuric acid, Bunsen burner, hydrogen peroxide (20 cm³), filter paper, test-tube and test-tube racks, 2M sodium hydroxide, filter funnel, 2M ammonia solution.

Procedure

1. Put about 0.5g of iron powder in a clean test tube and add 2cm³ of dilute sulphuric acid(2M). Warm the mixture gently and test the gas produced with a burning splint. Name the gas formed in the reaction.
2. Allow the solution to cool then filter and divide the filtrate into three portions
3. To the first portion add a few drops of 2M sodium hydroxide and shake the contents of the test-tube then allow it to settle. Identify the product formed then add dilute sulphuric acid to the product. Record your observation. Empty the contents immediately and then rinse the test-tube with plenty of water brushing it thoroughly as you do so.
4. To the second portion add a few drops of hydrogen peroxide followed by one or two drops of dilute sulphuric acid and warm gently. Allow the solution to cool (or cool it under running tap water). To the cold solution add drop wise 2M NaOH until there is no further change. Record your observations. Add dilute sulphuric acid to the resultant product and note down your observations. Rinse the test tube thoroughly.
5. To the third portion, add about 1 cm³ of dilute hydrogen peroxide solution followed by one or two drops of dilute sulphuric acid. Warm gently and test the gas produced with a glowing splint. Allow the solution to cool (or cool it using running tap water). To the cold solution add ammonia solution drop wise until no further change. Compare the product formed when ammonia solution to that obtained when sodium hydroxide was used.

Study Questions

1. Name the products formed when dilute sulphuric acid reacts with iron powder. Write a balanced formula equation for the reaction
2. When dilute sulphuric acid reacts with iron powder, iron atoms are oxidized and hydrogen ions are reduced. Write a balanced
 - a) oxidation half-equation
 - b) reduction half-equation and
 - c) overall redox equations for the reaction between iron and sulphuric acid
3. What is the effect of adding a hydrogen peroxide in step 4?
4. What will be the effect of adding concentrated nitric acid to any iron salt? Explain why concentrated nitric acid does not react with pure iron metal.

17.5.1. Rules for balancing redox reactions

The Half-Reaction Method for Balancing Oxidation–Reduction Reactions in Aqueous Solutions

For oxidation–reduction reactions that occur in aqueous solution, it is useful to separate the reaction into two **half-reactions**: one involving oxidation and the other involving reduction. For example, consider the unbalanced equation for the oxidation–reduction reaction between cerium(IV) ion and tin(II) ion:

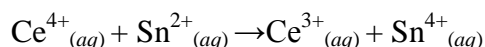

This reaction can be separated into a half-reaction involving the substance being *reduced*,

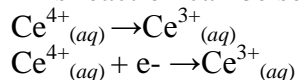

and one involving the substance being *oxidized*,

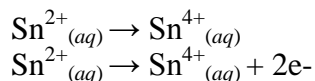

Adding the two half-reactions

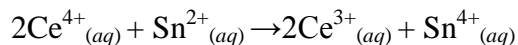
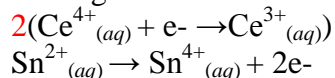

The general procedure is to balance the equations for the half-reactions separately and then to add them to obtain the overall balanced equation. The half-reaction method for balancing oxidation–reduction equations differs slightly depending on whether the reaction takes place in aqueous, acidic or basic solution.

a) The half-reaction method for balancing equations for oxidation–reduction reactions occurring in acidic solution

1. Write separate equations for the oxidation and reduction half-reactions.
2. For each half-reaction,
 - a. balance all the elements except hydrogen and oxygen.
 - b. balance oxygen using H_2O .
 - c. balance hydrogen using H^+ .
 - d. balance the charge using electrons.
3. If necessary, multiply one or both balanced half-reactions by an integer to equalize the number of electrons transferred in the two half-reactions.
4. Add the half-reactions, and cancel identical species.
5. Check that the elements and charges are balanced.

Example

Permanganate ions oxidize iron (II) to iron (III) in sulfuric acid solution. Permanganate ions are reduced to manganese (II) ions. Write the balanced net ionic equation for this reaction.

Solution

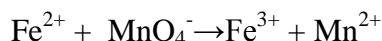

Oxidation half-reactions

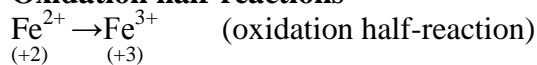

Reduction half-reactions

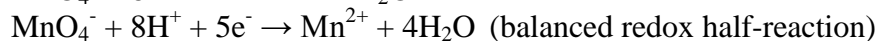
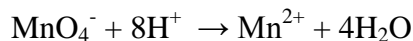

The oxidation half-reaction involves one electron, and the reduction half-reaction involves five electrons. Now we balance the number of electrons transferred in each half-reaction by multiplying each half-reaction by an integer factor. Then we add the two half-reactions and cancel out the equal number of electrons on each side.

This gives the balanced net ionic equation

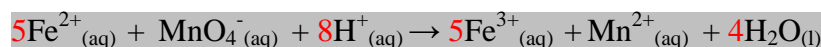
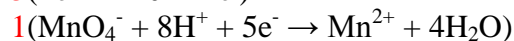
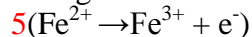

Check for mass balance: All elements appear in equal numbers on both sides.

Check for charge balance: Each side has a total charge of +17.

b) The half-reaction method for balancing equations for oxidation–reduction reactions occurring in basic solution

As for acid medium, in basic solution, OH⁻ and if necessary H₂O are appropriately added to balance hydrogen and oxygen atoms. The example below shows how to proceed.

Example:

In basic solution, hypochlorite ions, ClO⁻, oxidize chromite ions, CrO₂⁻, to chromate ions, CrO₄²⁻ and are reduced to chloride ions: CrO₂⁻ + ClO⁻ → CrO₄²⁻ + Cl⁻

Write the balanced net ionic equation for this reaction

Oxidation half-reactions



OH⁻ ions are added at the left side of the equation to balance oxygen atoms

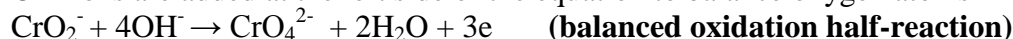

Reduction half-reactions

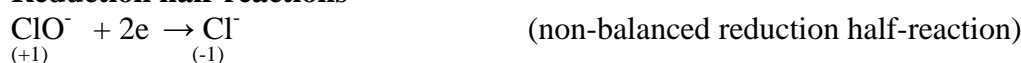

OH⁻ ions must be added at the right side of the equation to balance oxygen atoms

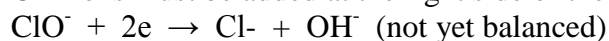

To balance hydrogen atom, molecule (s) of water must be added at the left side of the equation

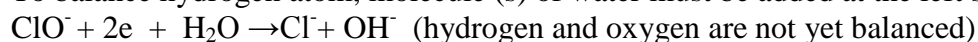

There are more oxygen and hydrogen on the left side; this can be balanced by multiplying OH⁻ on the right side by 2:

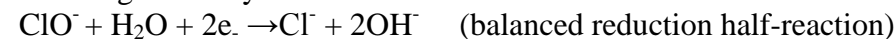

The oxidation half-reaction involves three electrons, and the reduction half-reaction involves two electrons. We balance the number of electrons transferred in each half-reaction by multiplying each half-reaction by an integer factor to equalize the number of electrons lost and gained. Then we add the two half-reactions together and cancel out the equal number of electrons on each side.

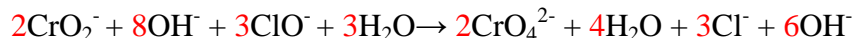
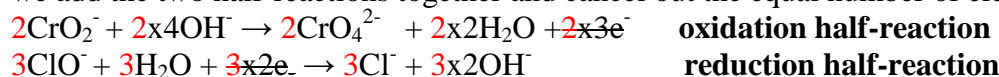

We see that 6OH⁻ and 3H₂O can be eliminated from both sides to give the balanced net ionic equation



Check for mass balance: all elements appear in equal numbers on both sides.

Check for charge balance: Each side has a total charge of -7

CAUTION!

The common household chemicals, such as Vinegar and bleach, should never be mixed because they react to form chlorine, in a redox reaction to form a very poisonous gas:



17.5.2. Concept of disproportionation reactions

Disproportionation is a chemical reaction, typically a redox reaction, where an element in a molecule or chemical species is simultaneously oxidized and reduced.

An example is the disproportionation of copper in the following reaction:

$\text{Cu}_2\text{O}_{(aq)} + \text{H}_2\text{SO}_{4(aq)} \rightarrow \text{Cu}_{(s)} + \text{CuSO}_{4(aq)} + \text{H}_2\text{O}_{(l)}$: Here the copper goes from oxidation state +1 in Cu_2O to oxidation state 0 in Cu and oxidation state +2 in CuSO_4 .

Other examples:

a) Chlorine disproportionates in alkali:

$\text{Cl}_2 + 2\text{OH}^- \rightarrow \text{Cl}^- + \text{OCl}^- + \text{H}_2\text{O}$: Here the chlorine goes from oxidation state 0 in Cl_2 to oxidation state -1 in Cl^- and oxidation state +1 in OCl^-

b) Disproportionation of copper (I) chloride

$2\text{CuCl} \rightarrow \text{CuCl}_2 + \text{Cu}$: Here the copper goes from oxidation state +1 in CuCl to oxidation state +2 in CuCl_2 and oxidation state 0 in Cu

c) Disproportionation of hydrogen peroxide

$2\text{H}_2\text{O}_2 \rightarrow 2\text{H}_2\text{O} + \text{O}_2$: Here the oxygen goes from oxidation state -1 in H_2O_2 to oxidation state -2 in H_2O and oxidation state 0 in O_2

Checking up 17.5

Use the half-reaction method and balance the following equations under the listed conditions.

- $\text{CN}^-_{(aq)} + \text{MnO}_4^-_{(aq)} \rightarrow \text{CNO}^-_{(aq)} + \text{MnO}_{2(s)}$ (basic solution)
- $\text{Cr}_2\text{O}_7^{2-}_{(aq)} + \text{I}^-_{(aq)} \rightarrow \text{Cr}^{3+}_{(aq)} + \text{IO}_3^-_{(aq)}$ (acidic solution)
- $\text{MnO}_4^-_{(aq)} + \text{CH}_3\text{OH}_{(l)} \rightarrow \text{Mn}^{2+}_{(aq)} + \text{HCO}_2\text{H}_{(l)}$ (acidic solution)
- $\text{As}_{(s)} + \text{ClO}_3^-_{(aq)} \rightarrow \text{H}_3\text{AsO}_3_{(l)} + \text{HClO}_{(l)}$ (acidic solution)
- $\text{H}_2\text{O}_2_{(l)} + \text{ClO}_2_{(l)} \rightarrow \text{ClO}_2^-_{(aq)} + \text{O}_{2(g)}$ (basic solution)

17.6. Reactivity series of metals

Activity 17.6

Carry out the following experiment regarding the displacement reaction and the reaction of sodium, magnesium, zinc, and copper with cold/hot water and dilute hydrochloric acid

Equipments/materials

- Metal samples (of consistent mass and surface area): Na, Mg, Zn, Cu
- 1.0 M solution of copper (II) sulphate, $\text{Cu}(\text{SO}_4)_2$,
- Distilled water
- Test tubes/ test tube rack
- 3 M HCl
- 400 mL Beaker

Procedure

1. Place a small sample of each metal in test tubes containing 5 mL of cold water. For metals like magnesium, it may be necessary to clean the outside of the metal with steel wool. Watch for evidence of reaction and note any changes you observe
2. Place the test tubes in a 400 mL beaker that is about 1/3 full of boiling water. After a few minutes, look for evidence of reaction. Note any changes. Did some metals that didn't react with cold water, react with hot water?
3. Place a small sample of each metal in test tubes containing 5 mL of 1.0 mol/L hydrochloric acid, HCl. Watch for evidence of reaction. Note any changes
4. Place a small sample of magnesium ribbon in test tube containing 5 mL of 1M copper (II) sulphate. Watch for evidence of reaction and note any changes

Study questions

- 1) Considering sodium, magnesium, zinc, and copper: Arrange the metals in order of increasing reactivity (from least reactive to most reactive)
- 2) Which of the four metals are reacting with cold water? For those metals that did react, write a balanced symbolic equation.
- 3) Which of the four metals are reacting with hot water? For those metals that did react, write a balanced symbolic equation.
- 4) Which of the four metals are reacting with the hydrochloric acid? For those metals that did react, write a balanced symbolic equation.
- 5) Which metal did not react with either water or hydrochloric acid?
- 6) Which of the four metals would be suitable for making saucepans? Explain why the others are not.
7. Describe what you would see if you dropped a piece of magnesium ribbon into some copper (II) sulphate solution in a test tube. Write a chemical equation for the reaction.

The reactivity series is a series of metals, in order of reactivity, as reducing agents, from highest to lowest reducing agent. It is used to determine the products of single displacement reactions, whereby metal A will displace another metal B in a solution if A is higher in the series. Although hydrogen is not a metal, it is included in the activity series for comparison.

When a metal in elemental form is placed in a solution of another metal salt it may be more energetically feasible for this "elemental metal" to exist as an ion and the "ionic metal" to exist as the element. Therefore the elemental metal will "displace" the ionic metal and the two swap places.

Examples of displacement reactions



Chemical equation	Chemical reaction
$\text{CuSO}_{4(\text{aq})} + \text{Mg}_{(\text{s})} \rightarrow \text{Cu}_{(\text{s})} + \text{MgSO}_{4(\text{aq})}$ <p style="text-align: center;">or</p> $\text{Cu}^{2+}_{(\text{aq})} + \text{Mg}_{(\text{s})} \rightarrow \text{Mg}^{2+}_{(\text{aq})} + \text{Cu}_{(\text{s})}$	
$\text{Fe}_{(\text{s})} + \text{CuSO}_{4(\text{aq})} \rightarrow \text{Cu}_{(\text{s})} + \text{Fe}_2(\text{SO}_4)_{3(\text{aq})}$ <p style="text-align: center;">Or</p> $\text{Fe}_{(\text{s})} + \text{Cu}^{2+}_{(\text{aq})} \rightarrow \text{Cu}_{(\text{s})} + \text{Fe}^{3+}_{(\text{aq})}$	

Table 17.2: Reactivity series of metals

	Metals	Metal Ion	Reactivity	
 <p style="color: orange; font-weight: bold;">Strongly reducing</p> <p style="color: orange; font-weight: bold;">Weakly reducing</p>	K	K ⁺	These elements react with aqueous H ⁺ ions (acids) or with liquid water to release H ₂ gas	
	Na	Na ⁺		
	Li	Li ⁺		
	Ba	Ba ²⁺		
	Sr	Sr ²⁺		
	Ca	Ca ²⁺		
	Mg	Mg ²⁺	These elements react with aqueous H ⁺ ions (acids) or with steam to release H ₂ gas	
	Al	Al ³⁺		
	Mn	Mn ²⁺		
	Zn	Zn ²⁺		
	Cr	Cr ²⁺		
	Fe	Fe ²⁺		
	Cd	Cd ²⁺		
	Co	Co ²⁺		
	Ni	Ni ²⁺		
	Sn	Sn ²⁺		
	Pb	Pb ²⁺		
	H ₂	H ⁺		included only for comparison
	Sb	Sb ²⁺		These elements do not react with aqueous H ⁺ ions (acids) to release H ₂ gas (they are highly unreactive)
	Bi	Bi ²⁺		
Cu	Cu ²⁺			
Hg	Hg ²⁺			
Ag	Ag ⁺			
Au	Au ³⁺			
Pt	Pt ⁺			

Only a metal higher in the reactivity series will displace another. A metal can displace metal ions listed **below** it in the activity series, but not above. For example, zinc is more active than copper and is able to displace copper ions from solution.

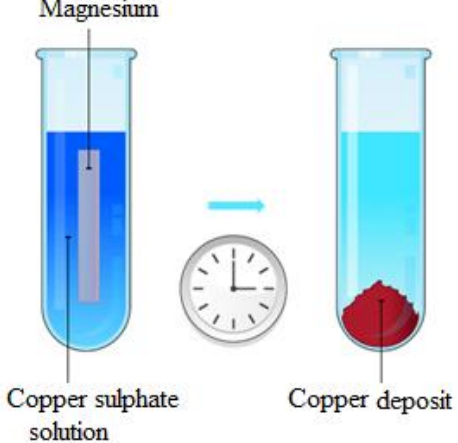
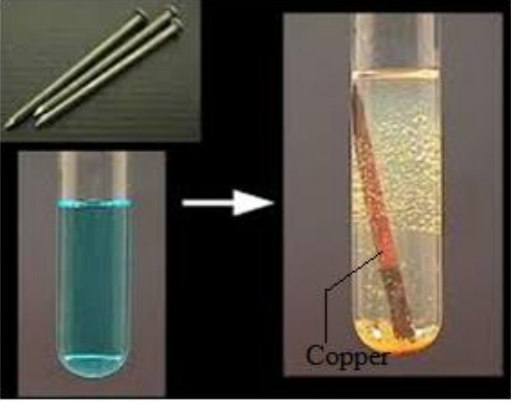

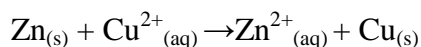
However, silver **cannot** displace copper ions from solution. It is important to distinguish between the displacement of hydrogen from an acid and hydrogen from water. Sodium is highly active and is able to displace hydrogen from water:

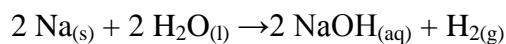

The less active metals like iron or zinc cannot displace hydrogen from water but do readily react with acids:

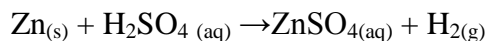

Those metals that can displace H^+ ions from acids are easily recognized by their position above hydrogen (H) in the activity series.

Conclusion: a more reactive metal will displace a less reactive metal from its salt solution (irrespective of which salt)

Checking up 17.6

- Complete the following word equations and then a chemical equation for each reaction.
 - zinc + lead nitrate solution
 - iron + zinc sulphate solution
 - lead + copper nitrate solution
 - magnesium + zinc chloride solution
 - copper + sodium chloride solution
 - zinc + iron sulphate solution
 - gold + silver nitrate solution
 - calcium + magnesium nitrate solution
- Three metals **X**, **Y** and **Z** have the following reactions:-
Y will displace **X** from a solution of its salt.
Z will displace both **X** and **Y** from solutions of their salts.
Place the three metals in order of reactivity, starting with the *least* reactive.
- Here is a list of metals in order of decreasing reactivity. **Q** and **R** are mystery metals.
 $\text{K} > \text{Q} > \text{Ca} > \text{Mg} > \text{Al} > \text{Zn} > \text{R} > \text{Fe} > \text{Cu}$
 - Will Q react with cold water?
 - Will R react with cold water?
 - Will R react with dilute hydrochloric acid?
 - Will R displace copper from copper sulphate solution?

17.7. End unit assessment

- Which of the following metals has an oxide which does not occur naturally? Explain.
A. Copper B. Gold C. Lead D. Aluminium
- In an acidified solution of Potassium Dichromate(VI) ($\text{K}_2\text{Cr}_2\text{O}_7$), dichromate ion ($\text{Cr}_2\text{O}_7^{2-}$) becomes reduced to
A. Chromate (V) ions B. Chromium (III) ions C. Chromium (II) ions D. Chromium (VI) ions
- In a reaction between $\text{CuSO}_{4(s)}$ and $\text{Zn}_{(s)}$,

- A. Zinc experiences an increase in oxidation state B. Zinc losses electrons
C. Zinc undergoes oxidation D. all of these

4. Oxidizing agents

- A. are mostly non-metals B. are mostly metals
C. decrease in oxidation state D. are mostly transition metals

5. In Copper Oxide (CuO) and Carbon Monoxide (CO) reaction to produce Cu and CO₂. A reducing agent is

- A. CuO B. CO C. Cu D. CO₂

6. In theory, most metals should easily corrode in air. Why? A group of metals called the noble metals namely gold, platinum, and silver are relatively difficult to corrode in air. Reference table 17.2 to come up with a possible reason why the noble metals are relatively difficult to corrode.

7. Gold metal will not dissolve in either concentrated nitric acid or concentrated hydrochloric acid. It will dissolve, however, in aqua regia, a mixture of the two concentrated acids. The products of the reaction are the AuCl₄⁻ ion and gaseous NO. Write a balanced equation for the dissolution of gold in aqua regia.

8. Consider only the species Na⁺, Cl⁻, Ag⁺, Ag, Zn²⁺, Zn, Pb in answering the following questions. Give reasons for your answers. (Use data from table 17.2.)

- Which is the strongest oxidizing agent?
- Which is the strongest reducing agent?
- Which species can be oxidized by SO₄²⁻(aq) in acid?
- Which species can be reduced by Al(s)?

9. The blood alcohol (C₂H₅OH) level can be determined by titrating a sample of blood plasma with an acidic potassium dichromate solution, resulting in the production of Cr³⁺(aq) and carbon dioxide. The reaction can be monitored because the dichromate ion (Cr₂O₇²⁻) is orange in solution, and the Cr³⁺ ion is green. The unbalanced redox equation is

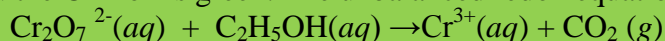

- Establish a balanced oxidation and reduction half-reactions
 - Hence write a balanced redox equation
10. When aluminum foil is placed in hydrochloric acid, nothing happens for the first 30 seconds or so. This is followed by vigorous bubbling and the eventual disappearance of the foil. Explain these observations.
11. Which of the following statements concerning corrosion is(are) *true*? For the false statements, correct them.
- Corrosion is an example of an electrolytic process.
 - Corrosion of steel involves the reduction of iron coupled with the oxidation of oxygen.
 - The key to cathodic protection is to connect via a wire a metal more easily oxidized than iron to the steel surface to be protected.

12. Suggest a list of the substances where nitrogen can exhibit oxidation states from -3 to +5.

13. When chlorine gas reacts with hot and concentrated sodium hydroxide solution, the oxidation number of chlorine changes from

- A. zero to +1 and zero to -5
- B. zero to -1 and zero to +5
- C. zero to +1 and zero to +5
- D. Zero to +1 and zero to -3

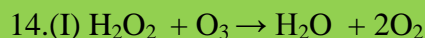

Role of hydrogen peroxide in the above reaction is respectively

- A. oxidizing in (I) and reducing(II)
- B. reducing in (I) and oxidizing in(II)
- C. Reducing in (I) and (II)
- D. oxidizing in (I) and (II)

15. Explain the following terms: oxidation half equation; reduction half equation; oxidizing agent; oxidant; reducing agent; reductant.

17. Using the ion electron half equation method, balance the following redox equations.

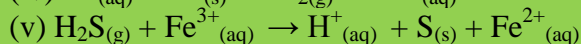
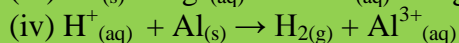
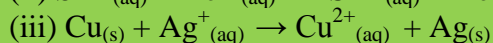
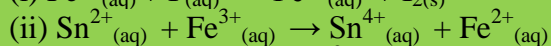
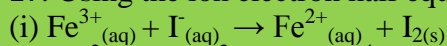

18. Indicate which of the following equations represent redox reactions by writing "redox" after the equation. Where the reaction is redox, give the oxidized species, the reduced species and their oxidation numbers.

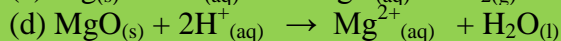
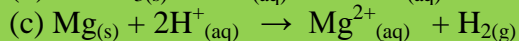
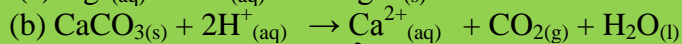

19. a) Record what you are expected to observe for the reactions between the metals and the solutions of their compounds. Write "no reaction" if no reaction took place.

	$\text{Mg}(\text{NO}_3)_2$	FeSO_4	$\text{Cu}(\text{NO}_3)_2$	$\text{Pb}(\text{NO}_3)_2$	$\text{Zn}(\text{NO}_3)_2$
Mg					
Fe					
Cu					
Pb					
Zn					

b) Write balanced equations for each reaction that took place.

20. Sulfur dioxide reacts with water to form sulfite ion. Is this a redox reaction? Justify your answer.

21. In each of the following balanced redox equations, identify:

- i) the species oxidized and their new oxidation numbers
- (ii) the species reduced and their new oxidation numbers.
- (iii) the reducing agent
- (iv) the oxidizing agent

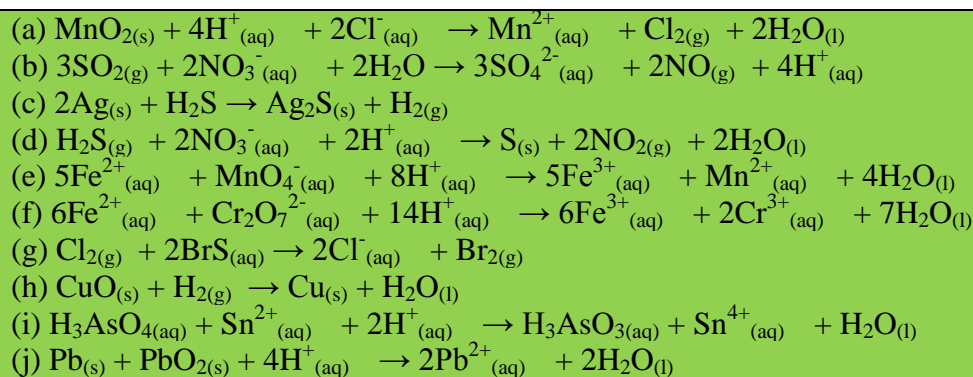

22. (a) Put the metals used (magnesium, copper, iron, zinc) in order from the least reactive to the most reactive. The more reactive metal will displace the other metal from the solution of its metal salt.

(b) Give the ionic equations for the reactions and explain why they are redox reactions.

(c) Chromium is more reactive than copper but less reactive than magnesium. Use this information to complete the following word equations:

i) copper + chromium sulfate \rightarrow

ii) magnesium + chromium sulfate \rightarrow

iii) chromium + copper sulfate \rightarrow

(d) Compare the reactivity of chromium with those of iron and zinc.

UNIT 18: ENERGY CHANGES AND ENERGY PROFILE DIAGRAMS

Key unit Competency: Explain the concept of energy changes and energy profile diagrams for the exothermic and endothermic processes.

Learning Objectives

By the end of this unit, student will be able to:

- Define the term Thermochemistry.
- Explain the concept of system and distinguish between the types of systems.
- Distinguish between Temperature and heat.
- Explain the concept of Exothermic and endothermic reactions and represent them using energy profile diagrams.
- Carefully deal with reactions that produce a lot of energy.
- Appreciate the use of chemical energy in daily life.
- Exhibit the team working spirit.
- Respect the experimental protocol during chemistry practicals.
- Relate the type of reaction to its energy profile diagram.
- Interpret the experimental results about energy changes occurring during chemical reactions.
- Explain the energy change as a function of the breaking and formation of chemical bonds.
-

Introductory activity 18

You are provided with the following chemicals and apparatus

- Zinc granules
- Dilute hydrochloric acid (2HCl)
- Quicklime or Calcium oxide (CaO).
- Ammonium chloride (NH₄Cl)
- Sodium thiosulphate (Na₂S₂O₃.5H₂O)
- Distilled Water
- A thermometer
- 4 Beakers labeled A, B, C and D.
- 4 Spatulas
- 4 test tubes

Procedure:

1. In beaker labeled A put dilute hydrochloric acid.
In beaker labeled B put water.
Read and record the initial temperatures of both solutions.
2. In beaker A put zinc granules using a spatula.
In beaker B put calcium oxide using a spatula.
Read and record the final temperatures of both solutions.
3. In beaker labeled C put 100 cm³ distilled water.
In beaker labeled D put 100 cm³ distilled water
Read and record the initial temperatures of both solutions.
4. In beaker C put one end full spatula of Ammonium chloride.
In beaker D put one end full spatula of sodium thiosulphate.
Read and record the final temperatures of both solutions.

Study questions

1. Fill the following table.

Substance	Initial Temperature (°C)	Final Temperature (°C)
A		
B		
C		
D		

2. Which reactions produce heat?
3. Which reactions absorbed heat?
4. List 2 uses of heat in everyday life.

18.1. Concept of a system

Activity 18.1

Topic: Energy transfer between a system and surroundings.

Apparatus and equipment (per group)

- Eye protection
- Four test-tubes or four expanded polystyrene cups with lids to act as calorimeters
- Spatula
- Teat pipette or small measuring cylinder
- Thermometer
- Access to a balance.

Chemicals (per group)

Anhydrous copper (II) sulfate.

- Citric acid crystals (2-hydroxy-1, 2, 3-propane tricarboxylic acid).
- Sodium hydrogencarbonate (baking powder).
- Copper (II) sulfate solution 0.5 mol dm^{-3} .
- Zinc powder.

Procedure

Experiment 1.

1. Put 100 cm^3 of water in a test-tube.
2. Record the temperature of the water.
3. Add a spatula measure of anhydrous (white) copper (II) sulfate.
4. Carefully stir, using the thermometer, and record the temperature again.

Experiment 2.

1. In a dry test-tube mix one spatula measure of citric acid and one spatula measure of sodium hydrogencarbonate.
2. Put 100 cm^3 of water in another test tube.
3. Record the temperature of the water.
4. Add the mixture to the water.
5. Watch what happens and take the temperature of the solution.

Experiment 3.

1. Put about 5 cm^3 of copper (II) sulfate solution in a test-tube.
2. Record the temperature.
3. Add a spatula measure of powdered zinc.
4. Record the new temperature.

Safety

- Wear eye protection.

- Anhydrous copper (II) sulfate is harmful.
- Zinc powder is flammable.

Introduction

Instant hot and cold packs are available for use in first aid. This experiment illustrates the types of chemical reaction that occur in these packs.

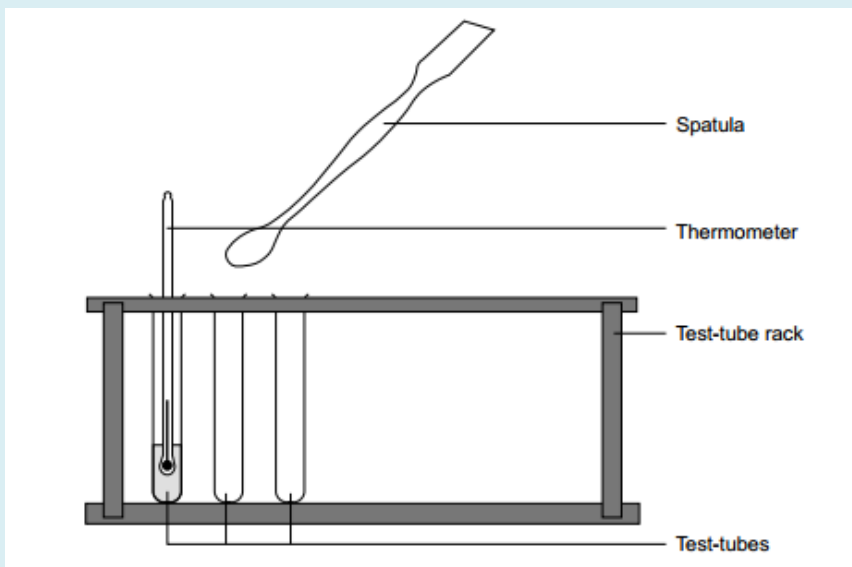

What to record

What was done and any changes in temperature from the starting temperature of your reaction. A table may be useful.

Initial solution	Temperature of solution /°C	Solid added	Final temperature /°C	Temperature change /°C	Type of reaction

Study questions

1. Identify the reactions that are exothermic and those that are endothermic.
2. Write symbol equations to represent the chemical reaction taking place in Experiment 3.
3. Which two substances could be put in a cold pack?
4. Golfers need a hand warmer to keep their hands warm on a cold day. Which chemicals could be put in these warmers?

All of the chemical reactions involve the breaking of bonds in the reactants and the formation of new bonds in the products. The breaking of bonds result from the energy absorption and the bond formation is accompanied by the release of energy. Therefore, there is always a net energy change in a given chemical reaction.

Thermochemistry is the study of heat and energy associated with a chemical reaction or a physical transformation. Thermodynamics is the study of the relationship between heat, work, and other forms of energy. A reaction may release or absorb energy, and a phase change may do the same, such as in melting and boiling. Energy can be exchanged between a closed system and its surroundings by doing the process of heating.

A **system** is a part of the universe which is studied using laws of thermodynamics. Everything outside the system is the **surroundings**. An infinitely small region separating the system from the surroundings is termed as **boundary**. In Chemistry **the chemical system** consists of reactants and products. The systems are classified according to the number of factors including the composition and the interaction with the surroundings. A system can be homogeneous or heterogeneous. It can be in gaseous, liquid or solid state. A system is said to be in equilibrium when its properties do not change with time. The state of a system is described using its composition, temperature and pressure.

Three types of systems can be distinguished according to the exchange between the system and the surroundings in terms of matter and/ or energy.

1) **An open system** is a system that can exchange both matter and energy with the surroundings (Figure 18.1).

Examples:

- All reactions carried out in open containers.
- Evaporation of water in a beaker.
- Hot coffee in a cup.

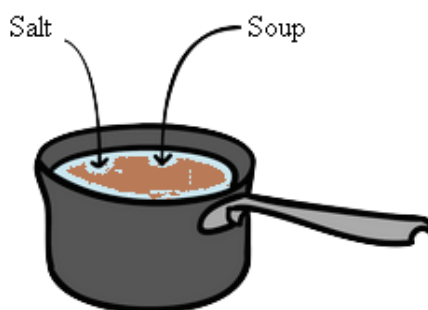

Figure 18.1 Example of an open system

2) **A closed system** is a system that can exchange energy but not matter with the surroundings (Figure 18.2).

Examples:

- All the reactions carried out in a closed container.
- Boiling water in a closed steel vessel.
- Boiling soup in a closed saucepan.



Figure 18.2 Example of a closed system

According to **Figures 18.1** and **18.2**, both the saucepans without a lid and with a lid, respectively, can absorb heat from the stove and get heated. There is exchange of energy taking place in both the cases from the stove (surroundings) to the water (system). However, the saucepan with the lid prevents any change in the quantity of matter. That is, no matter is added to or removed from the saucepan. On the other hand, in the case of the saucepan without the lid various substances can be added from outside and thus change the mass of the content. Besides, matter can be removed from the system. As a conclusion, the lid prevents the exchange of matter between the system and the surroundings. The saucepan with a lid represents a closed system.

3) An isolated system is a system which is both sealed and insulated. It can exchange neither matter nor energy with its surroundings.

Examples

Hot coffee in a thermos flask (*Figure 18.3*). The latter is a closed system. The outer surface is insulated and thus no heat transfer takes place between the system and the surrounding.



Figure 18.3 Example of an isolated system

Checking up 18.1

1. Which type of thermodynamic system is an ocean? An aquarium? A greenhouse?
2. A closed system contains 2 g of ice. Another 2 g of ice are added to the system. What is the final mass of the system?
3. An isolated system has an initial temperature of 30 °C. It is then placed on top of a Bunsen burner for an hour. What is the final temperature?
4. What type of energy does a stationary pencil contain? Falling pencil?
5. What do the first and second laws of thermodynamics have to do with systems?

18.2. The internal Energy of a system and first Law of Thermodynamics

Activity 18.2

1. Calculate the kinetic energy of a running back that has a mass of 80 kg and is running at a speed of 8 m/s.
2. An apple of 154 g is placed in 1.5 m above the ground. Determine its gravitational potential energy? ($g = 9.81 \text{ m s}^{-2}$)
3. What is the kinetic energy of a skier who, at a certain point in his run down the hill, has a potential energy of 34 300 J and a mechanical energy of 50 725 J?

18.2.1. Internal energy

The first Law of Thermodynamics deals with energy that is transferred between a given system and its surroundings in form of heat. The exchange of energy is related to the energy that is stored in the system called **internal energy E**. The internal energy is the sum of the kinetic and potential energies of the particles that form a system.

- **Kinetic energy (K.E)** is the energy possessed by an object in motion such as translation, rotation or vibration.

$$K.E = \frac{1}{2} mv^2$$

Where m is the mass of a moving object and v is its speed.

- **Potential energy (P.E)** is the energy that an object has because of its position relative to some other objects. In chemistry, the P.E is associated with chemical bonds due to atoms/ions positions.

$$P.E = mgh$$

Where m = mass in kilograms (kg),

g = acceleration of gravity (9.81 m s^{-2})

h = position of the in meters (m).

The total internal energy of a system is the sum of its kinetic energy and its potential energy. Mathematically, the internal energy (U) of a system is given by the expression:

$$U = K.E + P.E$$

18.2.2. Heat energy and temperature

The heat of an object is the total energy of all the molecular motion inside that object. When two bodies are in contact, heat always flows from the object with the higher temperature to that of lower temperature. Heat transfer ceases when a thermal equilibrium is attained. The heat content of a body will depend on its temperature, its mass, and the material it is made of. Because heat is a form of energy, it is measured in Joules (J) or kilojoules (kJ) or calorie (cal). A calorie is

defined as the amount of energy needed to raise the temperature of one gram of water by one degree Celsius.

1 calorie (cal) = 4186 joules (J); 1000 cal = 1 kcal = 4.186 kJ.

The temperature is a measure of the average heat energy (thermal energy) of the molecules in a substance. When an object has a temperature of 100 °C, for example, it does not mean that every single molecule has that exact thermal energy. In any substance, molecules are moving with a range of energies, and interacting with each other. The temperature is measured using a variety of temperature scales. The most commonly used are degree Celsius (°C) and degree Kelvin (K).

$$K = ^\circ C + 273$$

Example: 0 °C = 273 K and 100 °C = 100 + 273 = 373 K

First Law of Thermodynamics

Thermodynamics is part of physical chemistry that deals with the relationships between heat and other forms of energy. In particular, it describes how thermal energy is converted to and from other forms of energy and how it affects matter. The first Law of Thermodynamics is a statement about conservation of energy and it categorizes the method of energy transfer into two basic forms: work (W) and heat (Q). The First Law of Thermodynamics states that energy can be converted from one form to another with the interaction of heat, work and internal energy, but it cannot be created or destroyed, under any circumstances. Internal energy refers to all the energies within a given system, including the kinetic energy of molecules and the energy stored in all of the chemical bonds between molecules.

For a closed system (without mass input and output), the internal energy is the sum of the heat energy and the work done by the system or the surroundings

$$\Delta U = Q + W$$

Where W is the energy transferred to the system by doing work and Q is the energy transferred to it by heating.

Let us consider a gas occupying a volume V_1 in cylinder with a movable piston on which an external pressure P is applied. If the temperature of the gas increases, it expands and occupies a new volume V_2 . The change in volume is represented as ΔV , as shown in **Figure 18.4**. The sign of the work depends on whether it is done by the surroundings on the system or vice versa (**Table 18.1**).

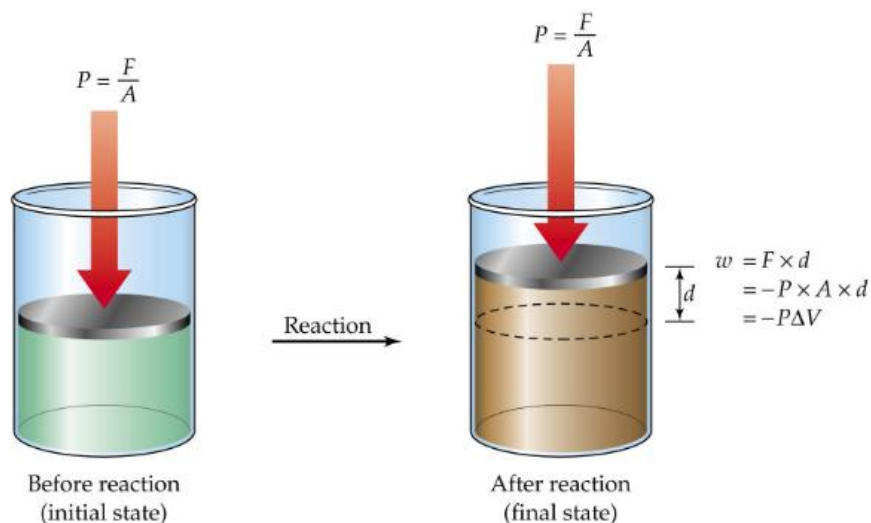

Figure 18.5: Interaction between a closed system and its surroundings.

The work done by the system on the surroundings is negative. Therefore, the first law of Thermodynamics is written as:

$$\Delta U = Q - W$$

Work (W) is also equal to the negative external pressure on the system multiplied by the change in volume. It can be expressed as:

$$W = -P\Delta V$$

Where P is the external pressure on the system, and ΔV is the change in volume. This is specifically called **pressure-volume work**. Therefore, the First Law of Thermodynamics is expressed using **equation**:

$$\Delta U = Q - P\Delta V$$

Table 18.1 Sign convention for Q, W and ΔU

Variable	Sign	Meaning
Q	+	The system gains heat
	-	The system loses heat
W	+	The work is done by the surroundings on system.
	-	The work is done by system on the surroundings.
ΔU	+	Net gain of energy by the system
		Net loss of energy by the system

Example:

What is the work of the gas that expands by 10.0 L against an external pressure of exactly 5.5 atmosphere?

Solution

Given that 1atm = 101,325 Pa,

$$\Delta H = -P\Delta V$$

$$= -5.5 \times 101,325 \text{ Pa} = 557,287.5 \text{ Pa} \times 10.0 \text{ L} = 5,572,875 \text{ J.}$$

Checking up 18.2

1. Four glasses of water are represented below.

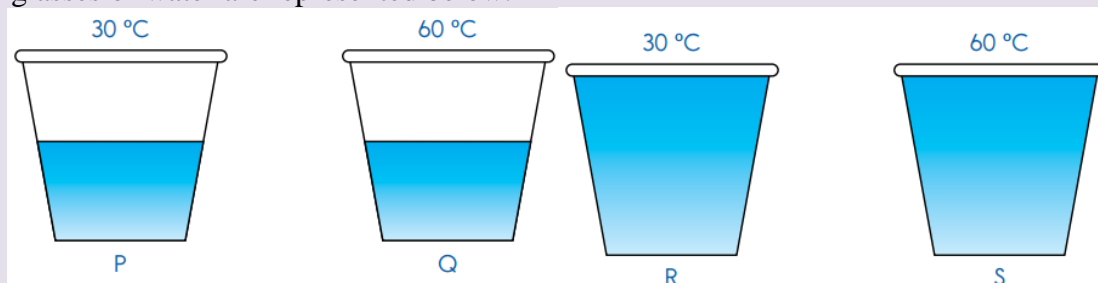

Glasses P and Q have the same amount of water. Glasses R and S have the same amount of water.

The water in Glasses P and R are at the same temperature. The water in Glasses Q and S are at the same temperature.

Fill in the blanks below with the correct answers.

- a. The water in Glass.....has the most heat.
 - b. The water in Glass.....has the least heat.
1. Ari touched a metal spoon. The metal spoon felt cold. Choose the best answer.
 - A. Heat flows from hand to spoon
 - B. Heat flows from spoon to hand
 - C. Heat does not flow
 - D. Heat flows in both directions
 2. Tom placed a metal spoon in a mug of hot coffee as shown below. The metal spoon felt hot. Choose the best answer.

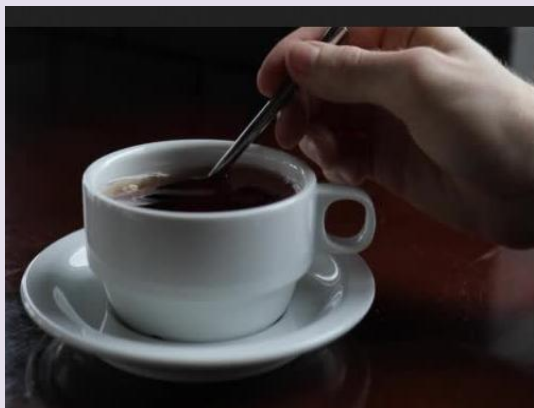

- A. Heat flows from hand to spoon
 - B. Heat flows from spoon to hand
 - C. Heat does not flow
 - D. Heat flows in both directions
3. Complete the statement below.

If two objects are near each other and one object is hotter than the other, then heat will flow from theobject to the.....object.

4. Complete the crossword puzzle using the clues given below.

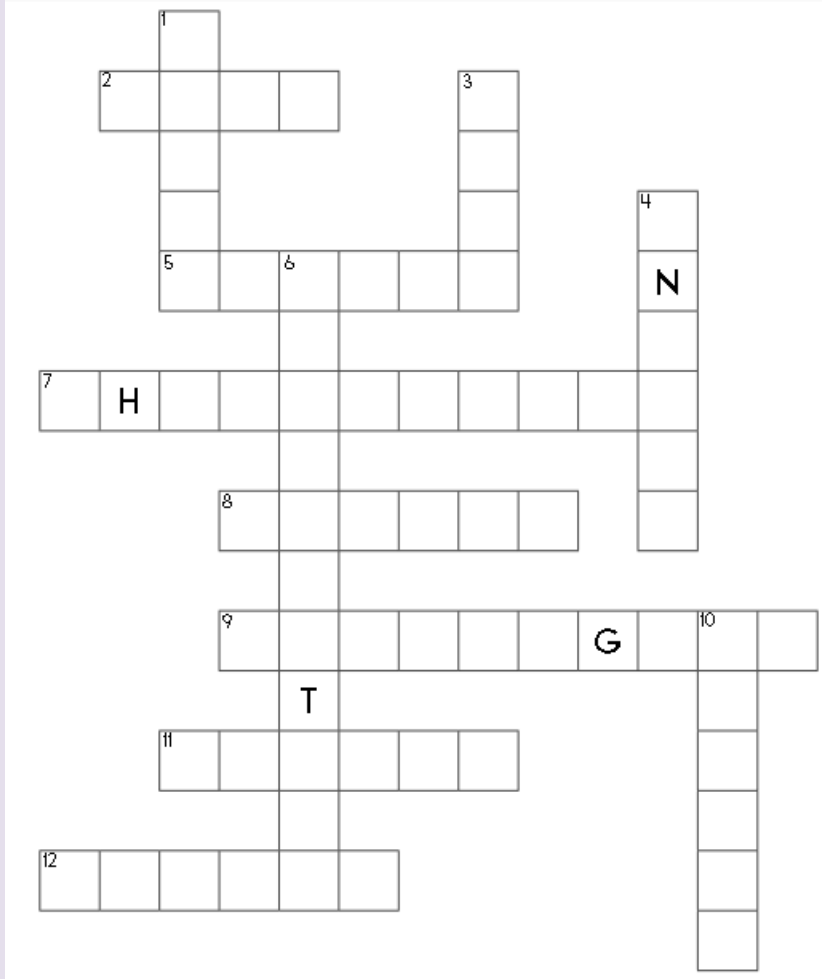

Down

- 1. Our sense ofcannot measure temperature accurately.
- 3. Wood is aconductor of heat.
- 4. Heat is a form of
- 6.is a measure of how hot or cold an object is.
- 10. Metals canwhen heated.

Across

- 2. Heat is used to food.
- 5. When two objects of different temperatures are in contact, heat will travel from the object to the other object.
- 7. The instrument used to measure temperature accurately is a
- 8. Temperature is measured in the unitCelsius (°C).
- 9. A....., when used with a temperature sensor, can be used to measure and record temperatures.

11. The Sun is an importantof heat.
 12. A hotter object will have atemperature.

18.3. Standard Enthalpy changes

Activity 18.3

1. What is meant by standard conditions of temperature and Pressure?
2. Which term describes the sum of kinetic energy and Potential energy?

The standard conditions referring to thermochemical measurements are:

Temperature = 25⁰C or 298 K.

Pressure = 1 atmosphere (atm) or 101, 325 Pa.

The concentration of solutions is 1.0 mol. dm⁻³ or 1.0 mol L⁻¹.

1. Standard enthalpy change of formation (ΔH_f^0)

The Standard enthalpy change of formation of a substance is the amount of heat released when one mole of that substance is formed from its elements under the standard conditions. It is represented by ΔH_f^0 .

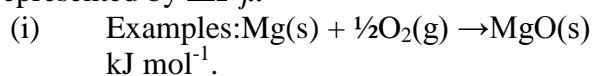

$$\Delta H_f^0 (\text{MgO (s)}) = - 602$$

It shows that the enthalpy change of formation of one mole of magnesium oxide from 1 mole of Mg and ½ mole of O₂ molecules is – 602 kJ mol⁻¹ (Figure 18.6)

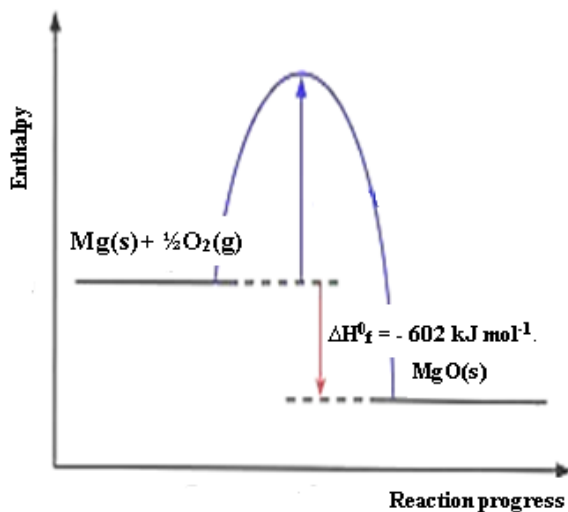

Figure 18.6. Energy profile diagram for the combustion of Magnesium

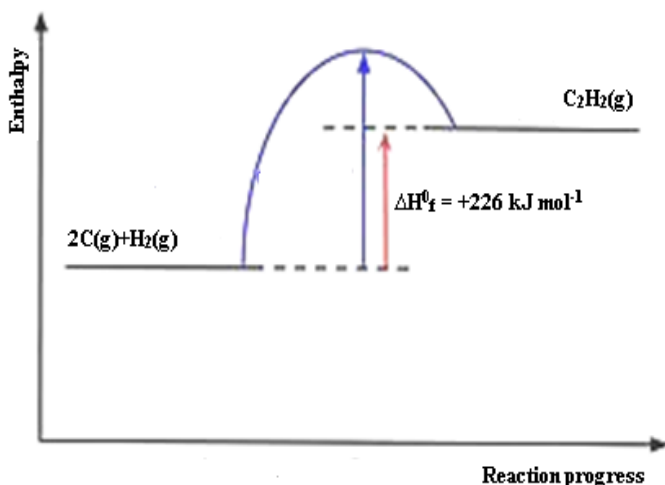
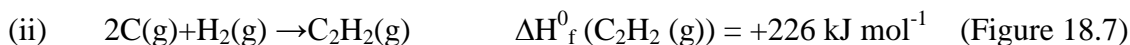

Figure 18.7: Energy profile diagram for the formation of Acetylene (C_2H_2)



Note: The standard enthalpy of formation of substances can be either negative or positive.

The compounds with more negative ΔH_f° values are more stable than compounds with more positive ΔH_f° values.

- The standard enthalpy of formation of elements is zero. However, for elements that exist in more than one allotropic form, only the most stable form under standard conditions is given zero standard enthalpy of formation.
- The compounds with a more negative enthalpy are more stable than the ones with a less negative and positive enthalpy change of formation.
-

2. Standard enthalpy change of Combustion (ΔH_c°)

The standard enthalpy change of combustion (ΔH_c°) of a substance *is* the heat evolved when 1 mole of the substance burnt completely in excess oxygen under standard conditions.

Examples

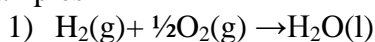

$$\Delta H_c^\circ = -286 \text{ kJ mol}^{-1}$$

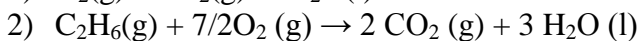

$$\Delta H_c^\circ = -890 \text{ kJ mol}^{-1}$$

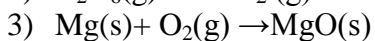

$$\Delta H_c^\circ = -602 \text{ kJ mol}^{-1}$$

Note: For compounds resulting from a direct combination of an element (metal or non-metal) and oxygen, the standard enthalpy of combustion is equal to the standard enthalpy of formation.

Examples:

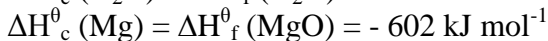
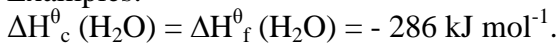

3. Standard enthalpy change of neutralization (ΔH_n°)

The standard enthalpy of neutralization, ΔH_n° is the enthalpy change which occurs when one gram equivalent of an acid is neutralized by one gram equivalent of a base to produce a salt and water under the standard conditions. The equation of the neutralization reaction is: $\text{H}^+(\text{aq}) + \text{OH}^-(\text{aq}) \rightarrow \text{H}_2\text{O}(\text{l})$

Examples:

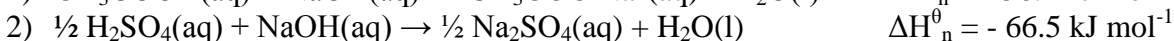
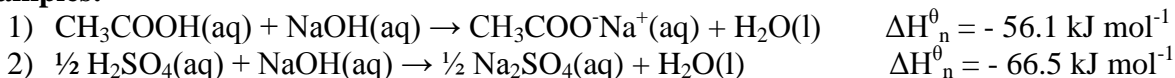

4. Lattice enthalpy (ΔH_{LE}°)

The lattice enthalpy is the amount of heat released when one mole of an ionic solid is formed from its gaseous ions under standard conditions. It is also the amount of heat absorbed when an ionic solid dissociates into its gaseous ions under standard conditions.

The lattice enthalpy is negative for the formation of the lattice and positive for the breaking of the lattice. There is a relationship between the size and charge of ions with the lattice enthalpy.

- i. The higher the **charge of the ions, the higher** the strong electrostatic attractions and the higher is the lattice enthalpy.
- ii. **The smaller is the size of ions, the higher is the strong** electrostatic attractions and the higher the lattice enthalpy.

Examples:

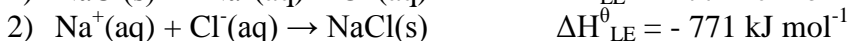
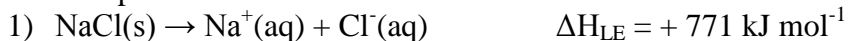

5. Standard enthalpy of Hydration ($\Delta H_{\text{Hyd}}^\circ$)

The standard enthalpy of Hydration also called **Standard enthalpy of solvation** is the amount of heat released when one mole of isolated gaseous ions dissolves in water forming one mole of aqueous ions under standard conditions. The positive terminal of the water molecule is attracted to the anion while its negative terminal is attracted to the cation. This is an ion-dipolar attraction which is typically an electrostatic interaction. This latter is accompanied by the release of heat energy.

Examples:



6. The enthalpy change of solution (ΔH_s)

The standard enthalpy change of solution is the change in enthalpy that occurs when one mole of a substance is dissolved in water to form an infinitely dilute solution under standard conditions.

The dissolution involves the breaking of the lattice into the ions and then there is hydration of these ions. Therefore, the standard *enthalpy change of solution is the sum of standard lattice enthalpy and standard enthalpy change of hydration*. It may be either positive or negative.

Examples:

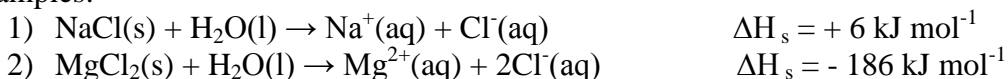

7. Standard enthalpy change of atomization (ΔH_{atm})

The **Standard enthalpy change of atomization** is the amount of heat required to form one mole of free gaseous atoms from its chemical substance under standard conditions. The enthalpy change of atomization is always positive.

Examples:



Note:

For diatomic molecules, this type of enthalpy is equal to the bond dissociation energy, B.D.E.

Bond energy also called **bond enthalpy** is a form of potential energy defined as the amount of energy required to break a given chemical bond. It has always positive values which depict the endothermic nature of the bond breaking. The energy required to form a chemical bond is equal in magnitude but opposite in sign to the energy required to break that bond. For example, the energy for breaking a hydrogen-hydrogen bond is $436 \text{ kJ}\cdot\text{mol}^{-1}$, and when a hydrogen-hydrogen bond is formed the process releases $436 \text{ kJ}\cdot\text{mol}^{-1}$. In a chemical reaction several bonds are broken and new ones are formed.

Energy change of reaction = Energy used to break bonds - Energy used to form bonds

Checking up 18.3

1. A gas is compressed and during this process the surroundings does 128 J of work on the gas. At the same time, the gas loses 270 J of energy to the surroundings as heat. What is the change in the internal energy of the gas?
2. Given the following information on mercury, Hg(1 atm), calculate the amount of heat needed at 1 atm to vaporize a 30.0g sample of liquid mercury at its normal boiling point of 357°C .
Boiling point = 357°C
Melting point = -38.9°C
Specific heat (liquid) = $0.139 \text{ J/g}\cdot^\circ\text{C}$

$$\Delta H_{\text{vap}}(357\text{ }^{\circ}\text{C}) = 59.3\text{ kJ/mol}$$

$$\Delta H_{\text{fus}}(-38.9\text{ }^{\circ}\text{C}) = 2.33\text{ kJ/mol}$$

18.4 Energy profile diagrams for Exothermic and Endothermic reactions.

Activity 18.4

Observe the following image and answer the related questions.

Potential energy

B

Energy in A

Energy out C

1. Discuss the type of energy form present in points A, B and C of the pathway followed by the vehicle.
2. Discuss how each form of energy changes from point A to point C.
3. Which points corresponds to maximum stability and minimum stability, respectively? Relate your answer to energy concept.

When a chemical reaction happens, the energy is transferred to or from the surroundings and often there is a temperature change. For example, when a bonfire burns, it transfers the heat energy to the surroundings. The objects near the bonfire become warmer and the temperature rise can be measured with a thermometer.

There are some chemical reactions that must absorb energy in order to proceed. These are endothermic reactions. Some other chemical reactions release energy to the surroundings. The energy released can take the form of heat, light, or sound. These are exothermic reactions.

1) Exothermic reactions

They are characterized by the increase in the temperature of the surroundings. They are denoted by a negative heat flow (heat is lost to the surroundings) and decrease in enthalpy ($\Delta H < 0$).

Examples of exothermic reactions are:

- 1) Burning different substances
- 2) Neutralization reactions between acids and alkalis
- 3) The reaction between water and calcium oxide
- 4) Termite reaction: This is the reduction of metal oxides in which a large amount of heat is liberated. It is very useful for the connecting of broken metal parts. When Aluminum powder reacts with iron oxide or chromium oxide, a large amount of heat is released (about 3500 °C is attained to weld broken metallic parts).

- 5) The mixture of sodium and chlorine to yield table salt is an exothermic reaction. This reaction produces 411 kJ of energy for each mole of salt that is produced from the reaction: $\text{Na(s)} + \frac{1}{2} \text{Cl}_2 \rightarrow \text{NaCl(s)}$

For an exothermic reaction (Figure 18.8), the total heat energy in the reactants is higher than the product, because the heat energy absorbed during bond breaking is lower than the heat energy released during bond formation.

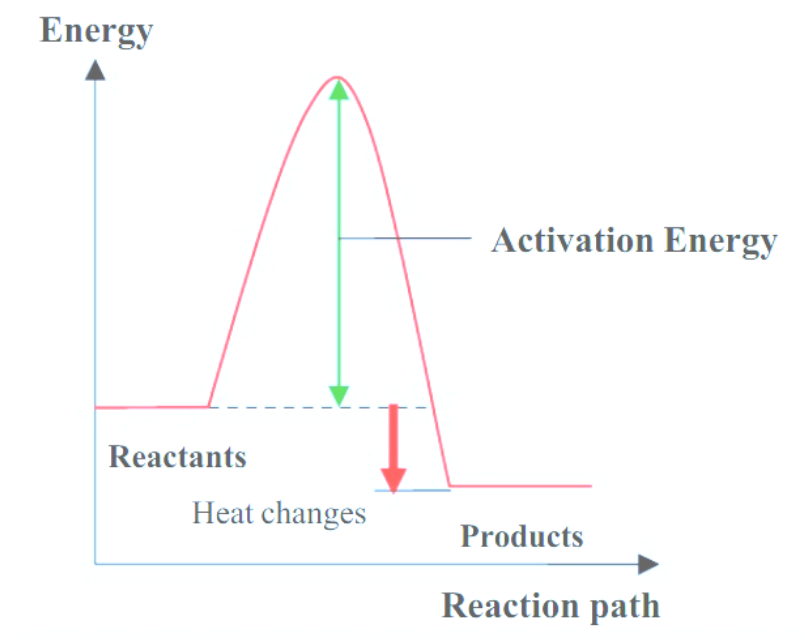

Figure 18.8: Energy profile diagram for exothermic reaction

2) Endothermic reactions

These are reactions that take place by absorbing the energy from the surroundings. The energy is usually transferred as heat energy, causing the reaction mixture and its surroundings to get colder. Endothermic reactions cannot occur spontaneously. Work must be done in order to get these reactions to occur. When endothermic reactions absorb energy, a temperature drop is measured during the reaction. Endothermic reactions are characterized by positive heat flow (into the reaction) and an increase in enthalpy ($+\Delta H$).

Examples

- 1) The reaction between ethanoic acid and sodium carbonate
- 2) The thermal decomposition of calcium carbonate in a blast furnace
- 3) Baking bread
- 4) Cooking an egg

- 5) Photosynthesis is an endothermic chemical reaction. In this process, plants use the energy from the sun to convert carbon dioxide and water into glucose and oxygen. This reaction requires 15 kJ of energy (sunlight) for every kilogram of glucose that is produced from the reaction:
- 6) $6\text{CO}_2(\text{g}) + \text{H}_2\text{O}(\text{l}) + \text{sunlight} \rightarrow \text{C}_6\text{H}_{12}\text{O}_6(\text{aq}) + 6\text{O}_2(\text{g})$.
- 7) Water evaporation

For endothermic reaction (Figure 18.9), the total Heat Energy in the reactants is lower than the product, because the heat energy absorbs during bond breaking is higher than the heat energy releases during bond formation.

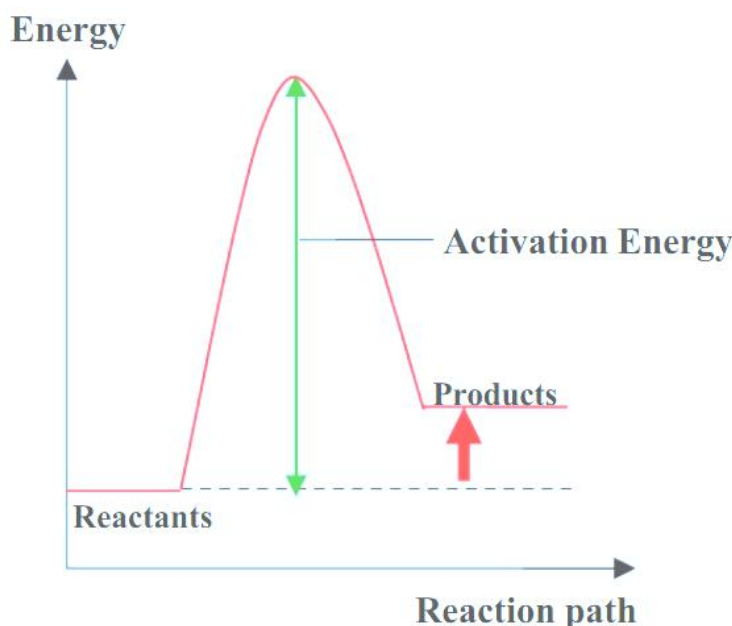
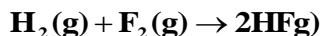

Figure 18.9: Energy profile diagram for endothermic reaction

Examples

1. Let us consider the reaction between hydrogen and fluorine to form hydrogen fluoride.



Determine the enthalpy change of the reaction and decide whether the reaction is endothermic or exothermic.

Data: The bond dissociation energies of H-H, F-F, and H-F are 436 kJmol^{-1} , 155 kJmol^{-1} and 567 kJmol^{-1} , respectively.

Solution:

The stoichiometric coefficients show that a hydrogen-hydrogen bond and a fluorine-fluorine bond are broken. Moreover, two hydrogen-fluorine bonds are formed. The overall energy change for this process is tabulated below.

Chemical species	Bond type	Number of bonds	Bond enthalpy (kJ mol ⁻¹)	Total bond enthalpy (kJ mol ⁻¹)
Reactants	H-H	1	436	436 × 1 = 436
	F-F	1	155	155 × 1 = 155
Products	H-F	2	567	567 × 2 = 1,134

Using the relation $\Delta H_{\text{rxn}} = \Delta H_{\text{prod}} - \Delta H_{\text{react}}$, gives

$$\begin{aligned}\Delta H_{\text{rxn}} &= [(436 \times 1) + (155 \times 1) - (567 \times 2)] \text{ kJ mol}^{-1} \\ &= (436 + 155 - 1134) \text{ kJ mol}^{-1} \\ &= -543 \text{ kJ mol}^{-1}\end{aligned}$$

2. Consider the complete combustion of butane and answer to the related questions. Given that the bond dissociation energies of reactants and products in the following table.

Bond type	Bond enthalpy (kJ mol ⁻¹)
C-C	348
C-H	413
O=O	495
C=O	799
O-H	463

- (a) Use bond energies to estimate the enthalpy change for the said reaction.
 (b) What is the nature of the reaction? Explain.

Solution:

- (a) The balanced equation for the reaction is the following:

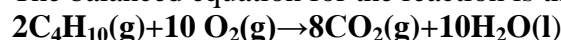

Referring to the values of bond energy in the **Table 18.1** and taking into consideration of the stoichiometric coefficients, the total bond enthalpy calculated is given as follows:

Chemical species	Bond type	Number of bonds	Bond enthalpy (kJ mol ⁻¹)	Total bond enthalpy (kJ mol ⁻¹)
Reactants	C-C	3 × 2 = 6	348	348 × 6 = 2,088
	C-H	10 × 2 = 20	413	413 × 20 = 8,260
	O=O	1 × 13 = 13	495	495 × 13 = 6,435
Products	C=O	2 × 8 = 16	799	799 × 16 = 12,784
	O-H	2 × 10 = 20	463	463 × 20 = 9,260

Using the relation $\Delta H_{\text{rxn}} = \Delta H_{\text{prod}} - \Delta H_{\text{react}}$, gives

$$\begin{aligned}\Delta H_{\text{rxn}} &= [(2,088 + 8,260 + 6,435) - (12,784 + 9,260)] \text{ kJ mol}^{-1} \\ &= (16,783 - 22,044) \text{ kJ mol}^{-1} \\ &= -5,261 \text{ kJ mol}^{-1}\end{aligned}$$

- (b) The reaction is exothermic, i.e. it releases heat. Exothermic processes are characterized by a negative enthalpy change, $\Delta H < 0$.

Checking up 18.5

Use the following potential energy diagram to answer the questions below:

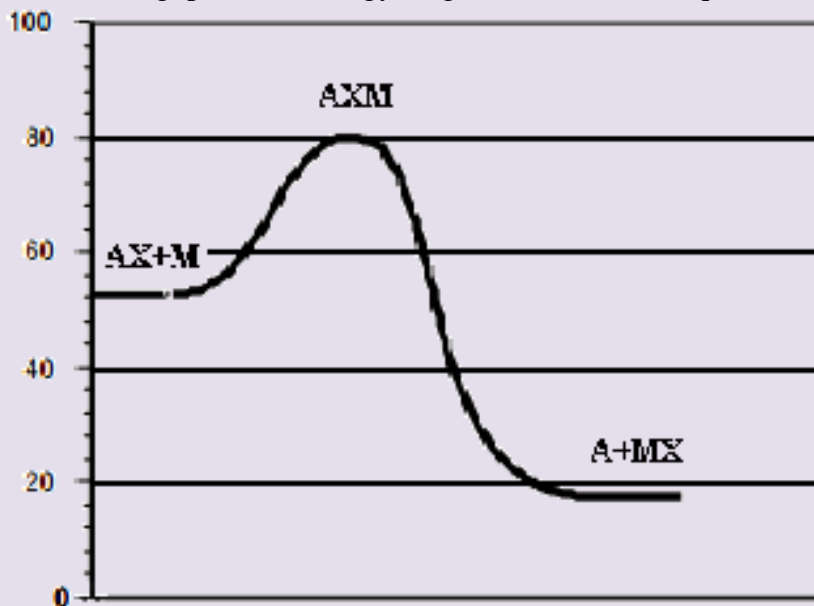

- 1) What is meant by *Activation energy*?
- 2) Determine the energy of the reactants.
- 3) Determine the energy of the products.
- 4) Determine the activation energy for the forward reaction.
- 5) Determine the activation energy for the reverse reaction.
- 6) Determine the enthalpy change of reaction for the forward reaction.
- 7) Determine the enthalpy change of reaction for the reverse reaction.
- 8) Fill in using exothermic or endothermic.
 - a. The forward reaction is
 - b. The reverse reaction is

- 9) Which chemical species or set of chemical species represent the activated complex?
- 10) Which one of the chemical bonds A-X and M-X is stronger? Explain.
- 11) State the chemical species whose particles move the fastest. Explain your answer.
- 12) State the chemical species whose particles move the fastest. Explain your answer.
- 13) The compound AX and the element M are in gaseous and solid states, respectively.
- 14) What effect would grinding M into a fine powder have on the above graph?

18.7. End unit Assessment

Observe the diagram hereafter and answer the related questions

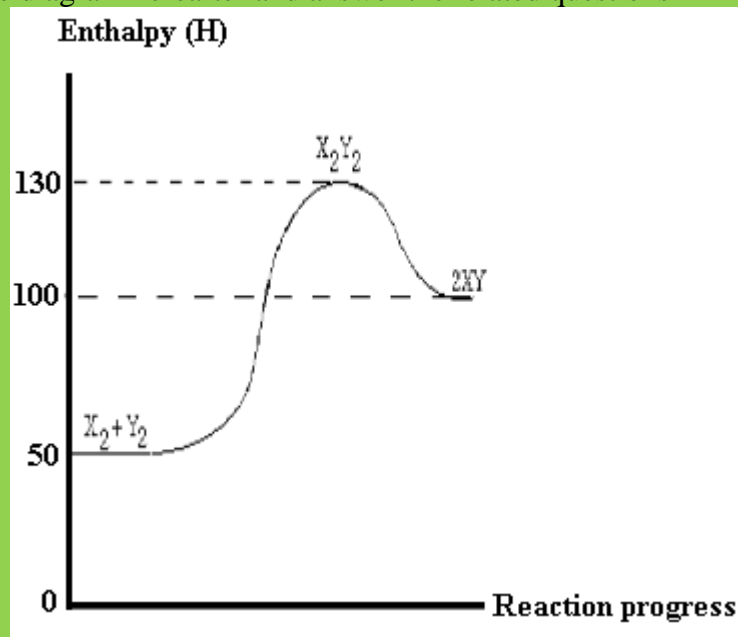

- 1) Regarding the absorption or release of energy, what is the nature of the overall reaction?
- 2) What is the activation energy for the forward reaction?
- 3) What is the activation energy for the reverse reaction?
- 4) Determine the enthalpy change of reaction for the forward reaction?
- 5) Determine the enthalpy change of reaction for the reverse reaction?
- 6) Is the reverse reaction endothermic or exothermic?
- 7) Which chemical species constitute the activated complex?
- 8) Which chemical species or set of chemical species have the maximum potential energy?
- 9) Which chemical species or set of chemical species have the maximum kinetic energy?
- 10) Which chemical species or set of chemical species have the strongest bonds?
- 11) Which chemical species or set of chemical species have the weakest bonds?

- 12) What is the enthalpy change of reaction for the reaction $X_2Y_2 \rightarrow X_2 + Y_2$?
As reactant particles approach each other before collision the potential energy goes
whereas the kinetic energy goes
- 13) Which one of the forward reaction and reverse reaction is more likely to be faster?
- 14) Which chemical species or set of chemical species have the minimum kinetic energy?
- 15) As particles of the newly formed product move away from one another their potential
energy goeswhile their kinetic energy goes
.....
- 16) State the meaning of the term Activated complex.
- 17) Which chemical species or set of chemical species correspond to the state of
maximum stability? Why?

REFERENCES

- Ajikumar, A. (2006). *The MCAT chemistry book. A comprehensive review of both general and organic chemistry*. Los Angeles: Nova Press.
- Allaby, M., Brawell, M., Daintith, J., Day, T., Haywood, J., Henderson, J., et al. (2006). *The facts on File chemistry handbook* (2nd ed.). New York, USA: Diagram Visual Information Ltd.
- Arthur, E., & Gary, F. (2003). *Active chemistry*.
- Cann, P. H. (2002). *Chemistry for Advanced level*. Landon: John Murray publishers Ltd.
- David, B. (n.d.). *Cambridge international AS and A level Chemistry revised guide*.
- Goldberg, D. E. (2007). *Fundamentals of Chemistry* (5th ed.). Mc-Graw Hill Companies.
- Graham Hill, J. H. (1995). *Chemistry in context* (Vol. Fourth edition). Surrey: Thomas Nelson and Sons Ltd.
- Jim, C. (2017). *chemguide*. Retrieved February 23, 2018, from <https://www.chemguide.co.uk/atoms/bondingmenu.html>
- Jim, C. (2017). *Chemguide*. Retrieved February 6, 2018, from [http://www.chemguide.co.uk/analysis/masspec/hw it works.html](http://www.chemguide.co.uk/analysis/masspec/hw%20it%20works.html)
- Jim, C. (2017). *Chemguide*. Retrieved February 20, 2018, from <https://www.chemguide.co.uk/atoms/structures/metals.html>
- Kasangandjo, L. (2013). *Advanced Level Chemistry*. Edinburgh: Pearson Education Limited.
- Kenneth, W. W., Raymond, E. D., Peck, M. L., & George, G. S. (2014). *Chemistry* (10th ed.). Belmont, USA: Brooks/Cole, Cengage Learning.
- Kotz, J. C., Treichel, P. M., & Townsend, J. R. (2012). *Chemistry and chemical reactivity* (8th ed.).
- Lister, T. R. (1995). *Understanding Chemistry for Advanced Level*. London: Cheltenham.
- Lwishi, K. (2013). *Chemistry S4* (Vol. First Edition). Essex, England: Pearson Education Limited.
- Martin, S. S. (1996). *The molecular nature of matter and change, fifth edition*. New York: Published by McGraw-Hill.

- Mukama, D. O. (2013). *Chemistry for Rwanda Secondary Schools, Advanced level*. Kigali: Fountain.
- Manish, B. (n.d.). *Deep Dive @ Sanfoundry*. Retrieved February 9, 2018, from <http://www.sanfoundry.com/analytical-instrumentation-questions-answers-components-mass-spectrometer/>
- Miloslav, N. (2009). *International Union of Pure and Applied Chemistry. 2005-2009. "IUPAC Gold Book. " Online Book*.
- Nivaldo, T. J. (2016). *Principles of Chemistry. A molecular Approach* (3th ed.). Pearson Education.
- S.Obonyo, D. (2013). *Chemistry for Rwanda Secondary Schools* (Vol. Advanced Level Senior 4). Kigali: Fountain Publishers Rwanda LTD.
- Peter Cann. Peter Hughes. (2002). *Chemistry for advanced level*. London: John Murry publishers Ltd.
- Peter, C., & Peter, H. (2015). *Chemistry for advanced level*. John Murray publishers Ltd.
- Petrucci, & Ralph, H. (2007). *General Chemistry: Principles & Modern Applications* (9th ed.). Pearson Prentice Hall.Upper Saddle River, NJ.
- Petrucci, R. H., Herring, F., Madura, J. D., & Bissonnette, C. (2011). *General Chemistry: Principles and Modern Applications* (10th ed.). Toronto, Ontario, USA: Pearson Prentice Hall.
- Ramsden, E. N. (2000). *Advanced Level Chemistry* (4th ed.). Cheltenham, United Kingdom: Nelson Thornes Ltd.
- Rasool, H. B. (2012). Mass Spectrometry (Importance and Uses). *Pharmaceut Anal Acta*, 3(10), doi:10.4172/2153-2435.1000e138.
- Ryan, L., & Norris, R. (n.d.). *Cambridge international A S and A Level Chemistry course book* (2nd ed.).
- Satya, P., G.D., T., S.K., B., & R.D., M. (1999). *Advanced Inorganic Chemistry* (16 ed., Vol. 1). New Delhi, India: S. CHAND& COMPANY LTD.
- Shriver, D., & Atkins, P. (1999). *Inorganic Chemistry*. Oxford University Press, Oxford 292.
- Silberberg, M. S. (2006). *CHEMISTRY: The Molecular Nature of Matter and Change* (4th ed.). New York, USA: The McGraw-Hili Companies, Inc.
- Wade, B. (2015). *CK-12 Chemistry-Intermediate*. USA: CK-12 Foundation.
- Zumdahl, S. S., & Zumdahl, S. A. (2007). *Chemistry* (7th ed.). Boston, USA/ University of Illinois: Houghton Mifflin Company.